

---

# 1989 COBALT

---

*The name, Cobalt, has become the symbol of excellence in the world of boating. Behind this name are the creators and makers who believe quality and owner satisfaction are unquestionably the most important parts of every boat we build.*

*No other boat is more respected for styling, comfort, convenience and attention to detail. Your concern for proper operation, care and maintenance will provide you with many years of boating satisfaction.*

*This manual has been prepared to acquaint you with the operation and maintenance of your Cobalt. We suggest you read this manual carefully and follow the recommendations to assure enjoyable and trouble-free operation.*

*As you read this manual, remember that "common sense" and "courtesy" are two of the most valuable traits you can have to fully enjoy and have a safe boating experience.*

*It is also to your own personal advantage to become well acquainted with the rules and general "know how" of boating.*

*For service and assistance, remember to call on your Cobalt dealer. He will be happy to assist you in matters concerning maintenance, warranty and any other questions you may have concerning your Cobalt.*

## TABLE OF CONTENTS

### I. Equipment and Government Regulations

- 1. Lights ..... 4
- 2. Whistle or Horn ..... 4
- 3. Fire Extinguisher ..... 4
- 4. Life Saving Devices ..... 4
- 5. Additional Recommended Equipment ..... 5
- 6. Inland Lakes ..... 5
- 7. Intracoastal Waters ..... 5

### II. Boating Industry Associations Certification .. 6

### III. Interior/Exterior Care

- 1. Vinyl Interior/Upholstery Care ..... 7
- 2. Vacuuming ..... 8
- 3. Carpet Care ..... 8
- 4. Teakwood Care ..... 8
- 5. Canvas/Top/Camper Care ..... 8

### IV. Boat Operation

- 1. Erecting Canvas Top ..... 12
- 2. Stowage of the Canvas Top ..... 19
- 3. Canvas Maintenance ..... 19
- 4. Seat Adjustment and Operation ..... 20
- 5. Cuddy Cabin Access Doors ..... 22
- 6. Instrument Panel ..... 23
- 7. Engine Control ..... 26
- 8. Steering System ..... 33
- 9. Power Trim ..... 34
- 10. Warning Labels ..... 35
- 11. High Speed Operation ..... 36

- 12. Lifting Rings On Your Cobalt ..... 36
- 13. Trash Receptacle ..... 38
- 14. Fold Down Boarding Ladder ..... 38
- 15. Water Ski Towing ..... 38
- 16. Deck Hatch ..... 39
- 17. Engine Accessibility ..... 39
- 18. Dual Batteries and Dual Battery Switches  
(Twin Engines) ..... 40
- 19. Optional Equipment ..... 41

### V. Propellers and Propeller Chart ..... 43

### VI. Technical Information

- 1. Engine Operation/  
Maintenance/Servicing ..... 47
- 2. The Break In Period ..... 47
- 3. Winterizing and Off-Season Storage ..... 47
- 4. Fuel Requirements ..... 49
- 5. Trouble Check Chart ..... 50
- 6. Wiring Diagrams ..... 54
- 7. Circuit Breakers ..... 54
- 8. Lighting/Bulb Replacement ..... 54
- 9. Specifications ..... 55-56
- 10. Cobalt Warranty ..... 66

### VII. Service Record Pages ..... 68

## I. EQUIPMENT AND GOVERNMENT REGULATIONS

### 1. Lights

Motorboats **underway** between sunset and sunrise must display proper lights. A boat at **anchor** must display a white anchor light less than 20 feet over the hull and must be visible for at least one mile to a boat approaching from any direction.

The lighting on your Cobalt complies with B.I.A., U.S. Coast Guard and A.B.Y.C. standards.

**NOTE: Consult your local and regional navigational authority for any additional lighting requirements.**

### 2. Whistle or Horn

All boats over 16 feet in length are required to have an operational horn or whistle which is audible at least one mile. Your Cobalt is so equipped.

**NOTE: Check your horn periodically for proper operation.**

### 3. Fire Extinguisher

All I/O boats are required to carry appropriate portable fire extinguishers. Your Cobalt is "standard equipped" to meet the fire extinguisher regulations.

**NOTE: Check your fire extinguisher gauge frequently to determine proper charge.**

### 4. Life Saving Devices

All boats must carry one Coast Guard approved type 1, 2, or 3, (wearable) device for every person on board. In addition, each boat over 16 feet in length is required to carry one approved type 4 throwable life saving device such as a ring life buoy or buoyant cushion. When the approval stamps are no longer legible and the equipment cannot otherwise be identified as being approved, the equipment must be replaced with currently approved equipment.

### 5. Additional Recommended Equipment

Cobalt Boats wants your recreation time to be enjoyable and without incident. We suggest the following items be aboard in the event of an accident or problem situation:

- |                           |                           |
|---------------------------|---------------------------|
| 1. Compass                | 5. Anchor and anchor line |
| 2. Distress signal flares | 6. Tool Kit               |
| 3. Flashlight             | 7. Paddle                 |
| 4. First Aid Kit          |                           |

**NOTE: It is recommended that you consult with your dealer for the appropriate types of safety devices for the area in which you boat.**

### 6. Inland Lakes

All boats operating on inland lakes are under the jurisdiction of state governments. You should check with your dealer for the source of the rules and regulations that will affect you on your local inland waterway.

### 7. Intracoastal Waters

Regulations governing equipment necessary while operating in intracoastal waters are different than inland rules. Make sure you have the proper equipment on board. The best source for information regarding rules and regulations for intracoastal waters is the U.S. Coast Guard.

**NOTE: The U.S. Coast Guard has all the information you will require for safe and legal operation of your boat in intracoastal waters. They also provide numerous informational pieces regarding general practices for safe and enjoyable boating. Your dealer will advise you on how to contact the U.S. Coast Guard or you may wish to call 202/267-0973.**

## II. BOATING INDUSTRY ASSOCIATIONS CERTIFICATION

Boating Industry Associations is a National Trade Association serving all elements of the Recreational Boating Industry.

Its members include manufacturers of all types of boating equipment - outboard and inboard boats, sailboats, marine engines, outboard motors, boat trailers, boating accessories and supplies.

B.I.A. certification means that you, a new Cobalt owner, can rest assured that lighting, ventilation, steering, flotation, capacity, fuel system, horsepower rating and anything that will insure your safety are within the rigid U.S. Coast Guard requirements. Your Cobalt is B.I.A. Certified, and meets U.S. Coast Guard and A.B.Y.C. standards.



## III. INTERIOR/EXTERIOR CARE

### 1. Vinyl Interior/Upholstery Care

The vinyl fabric in your Cobalt's interior has been especially selected to take the tough punishment of the elements and hard usage of an active boater. With all its toughness and wear qualities, it is no match for a screwdriver you forgot to take out of your pocket before sitting down — avoid sharp objects coming in contact with vinyl.

Keeping your Cobalt interior clean is easy. Ordinary dirt can be removed by washing with warm water and a mild soap. Apply soapy water to a large area and allow to soak for a few minutes. Brisk rubbing with a cloth should then remove most dirt. This procedure may be repeated in case of stubborn or imbedded dirt. A soft bristle brush may be used after the soap has been applied. Other cleaning suggestions: Chewing gum may be removed by careful scraping and by the application of kerosene or naphtha. Tars, Asphalt, Creosote — each of these items will stain the vinyl if allowed to remain in contact. Wipe off as quickly as possible and clean the area using a cloth dampened with kerosene or naphtha. Paint should be removed immediately. Do not use paint remover or liquid type brush cleaner. Use a white cloth dampened with kerosene or naphtha. Nail polish and nail polish remover — these substances will cause permanent harm to the vinyl. Fast and careful wiping or immediate blotting after contact will minimize the staining. Spreading liquid while removing should be avoided. Waxing and refinishing — waxing improves the wearability and cleanability of the vinyl. Use any hard wax.

**DANGER: FLAMMABLE LIQUIDS ARE EXTREMELY DANGEROUS AND SHOULD BE USED ONLY WITH THE GREATEST OF PRECAUTIONARY MEASURES. DO NOT USE A FLAMMABLE LIQUID IN YOUR BOAT WHEN ANOTHER CLEANER CAN BE USED.**

## 2. Vacuuming

A very effective and easy way to keep your interior ship shape is giving it a good vacuuming. You may use your own canister type or the ones available at a car wash. The vacuum cleaner allows you to pick up in tight areas such as under bow, jump and lounge seats. It's also a great way to clean up any debris in the bilge area. (If you're at a car wash, it's a good idea to use the pressure nozzle to wash the bilge area prior to vacuuming, using care not to direct spray on engine, carburetor, distributor, alternator or starter.)

## 3. Carpet Care

The carpet in your Cobalt is made of the finest materials available. It will not rot or mildew. Scrubbing with soapy water will handle most tough jobs. A simple hosing for mild cleanups will bring out that new look again. Your dealer can suggest methods of cleaning difficult stains in your carpet.

**DANGER: FLAMMABLE LIQUIDS ARE EXTREMELY DANGEROUS AND SHOULD BE USED ONLY WITH THE GREATEST OF PRECAUTIONARY MEASURES. DO NOT USE A FLAMMABLE LIQUID IN YOUR BOAT WHEN ANOTHER CLEANER CAN BE USED.**

## 4. Teakwood Care

While it is generally said that teakwood is maintenance free, it is better to consider teakwood as a material that requires a minimal amount of work to maintain.

If the care of teakwood is completely ignored, after a long period of time you can expect its color to turn gray. In addition to the fading of its color, the surface finish will tend to become rough. This roughing results and gradually becomes more apparent as the oil in the wood evaporates or dries out causing a shrinking and separation of the wood's grain.

For appearance sake and to avoid this "roughing" it is suggested that you use an application of the teak oil that has been supplied with your Cobalt. Instructions for use are on the label.

## 5. Canvas/Top/Camper Care

Boat canvas, in most cases, is subjected to more severe punishment than any other type of canvas or fabric item.

Moisture, dirt, heat, ultraviolet rays, salt water, and chemicals from industrial fallout are all factors anxious to destroy your boat canvas. These elements can do serious damage if left unchecked. Following are some ways to slow the destructive process of canvas:

**MOISTURE** — Can cause shrinkage, mold, (and mildew if fabric is not properly treated). The best method of prevention is to allow all canvas items to dry thoroughly while installed on the boat. Shrinkage can occur anytime an article is allowed to dry while loose. Most shrinkage will occur the first few months after initial installation. When canvas items are erected on the boat and properly adjusted, shrinkage can only occur in areas of looseness. Mold and mildew can be avoided by keeping your unit clean and well ventilated.

**DIRT** — Can create a starting point for mold when moisture is present. Cleaning periodically with a mild detergent and water while unit is erected on the boat will extend the canvas life and provide a better appearance. Cleaning can be accomplished with a sponge, soft scrub brush or by using one of the serve-yourself car washes. The unit should always be erected fully and adjusted to a tight, smooth appearance before washing. Allow unit to air dry thoroughly before removing curtains.

**CHEMICALS** — From industrial fallout can cause decay of vinyls and fabrics if allowed to accumulate. There are many different types of chemicals involved. Keeping your unit clean and covered is the best answer to prevent decay from chemical fallout. Many types of covers are available, check with your dealer for an appropriate cover for your use.

**HEAT** — Any vinyl coated fabric when enclosed in a polyethylene container and subjected to sunlight is subjected to potential cracks in the vinyl component and a stiffening effect on the fabric. Polyethylene bags or tubes are meant only for protection during shipping and handling.

**NOTE: Do not use polyethylene bags or tubes for storage of canvas.**

**ULTRAVIOLET DEGRADATION** — Most synthetic fabrics or nylon parts today are U.V.R. treated to resist ultraviolet effects.

The best protection, however, is to avoid long periods of stowage in areas subject to direct sunlight.

**SALT WATER** — Corrosive effects of salt water, as well as chemicals from industrial fallout, can corrode brass or aluminum fittings or fasteners. Your canvas has snap fasteners made of stainless steel. These can be protected by keeping them clean and occasionally lubricating them with petroleum jelly.

In summary, the things you can do to protect your canvas items for extended years of enjoyment are:

1. Keep it clean. DO NOT use harsh cleaners.
2. Side curtains and rear window demand extra care to prevent scratching. Ideally, they should be washed with clear water, preferably hosed off, wiping them with your hand at the same time. Do not attempt to use a cloth or chamois skin. Any dirt or grit in the cloth may result in scratches. Clear water and using your (clean) hand is the safest way. When storing canvas with windows or side curtains, they should be rolled rather than folded to prevent kinking and cracking.
3. Be sure that the top is completely dry before stowing.
4. Keep unit well ventilated when stowed. NO POLY BAGS.
5. Keep fasteners clean and lubricated.

The materials used to produce your boat top and curtains are the best obtainable. Reasonable care will assure them of a long life and many years of service.

**NOTE:** For storage, we recommend an optional travel/mooring cover of duck canvas that has the ability to breathe. Do not use convertible tops, side curtains, aft curtains, tonneau covers, etc. for long term storage. These tops were not designed for long term storage. Adequate ventilation is not possible and mold/mildew will form. For more information on appropriate covering for long term storage, please see your Cobalt Dealer.

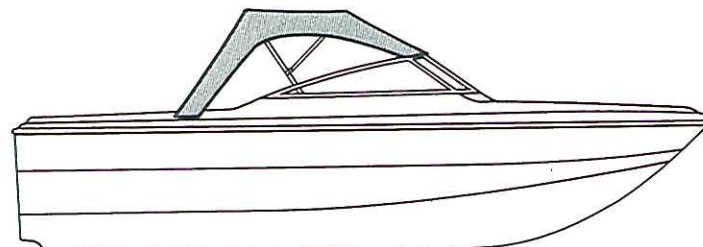

**Convertible Top**

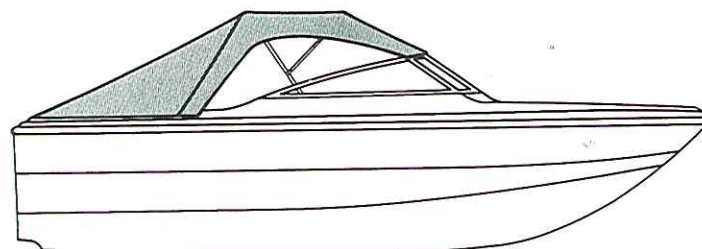

**Stern Curtain**

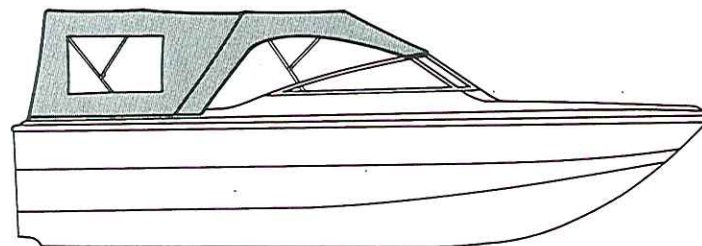

**Camper Top**

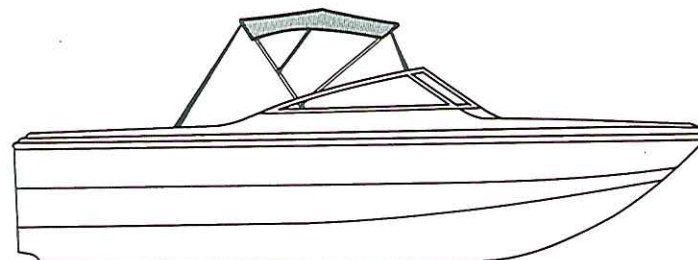

**Bimini Top**

## IV. BOAT OPERATION

### 1. Erecting Canvas Top (See Figure 1)

#### a. Convertible Top — (standard)

1. Remove canvas top, bow, and extension legs from “top storage area”.
2. Attach extension legs to top mounts on each side of the boat. (Use quick disconnect pins or knurled knobs.)
3. Slide top bow onto extension legs with the short bow closest to the windshield. (Note: some models do not use extension legs.)
4. Remove storage boot and unroll canvas top.
5. Open frame and snap front of canvas to windshield.
6. Snap the tail panels to the sides of the boat.

#### b. Side Curtains — optional (See Figure 2)

1. Zip the side curtains to the top.
2. Snap curtains to windshield and deck.

#### c. Stern Curtain — optional (See Figure 2)

1. Zip the stern curtain to the canvas top, snap the curtain to the deck, starting at the center rear of the curtain and working forward evenly.

#### d. Camper Top — optional (See Figure 3)

1. Install “Convertible Top” as outlined in (a).
2. Remove “Camper Top” extension legs from storage area.
3. Attach extension legs to “Camper Top” mounts (toward rear of boat) on each side of the boat.
4. Slide “Camper Top” bow into extension legs with the short bow toward the bow of the boat.
5. Remove storage boot and unroll “Camper Top” canvas.
6. Open “Camper Top” frame and zip front of “Camper Top” canvas to rear of “Convertible Top”.
7. Zip side curtains to “Convertible Top”.

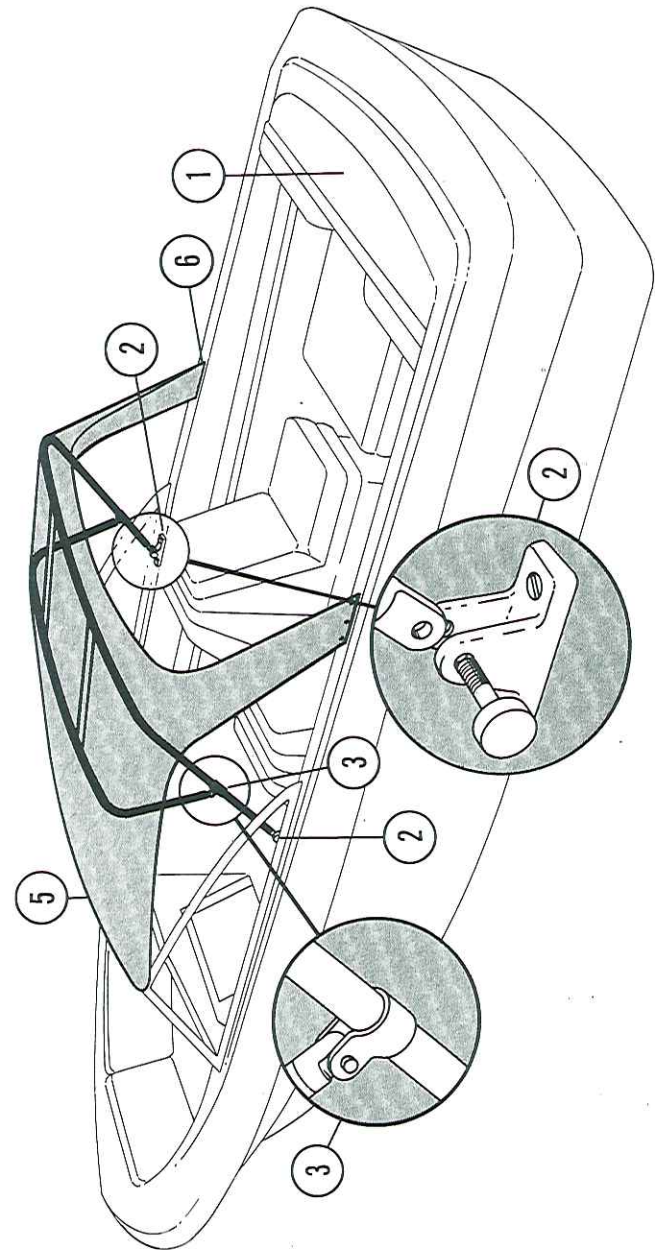

Convertible Top  
Figure #1

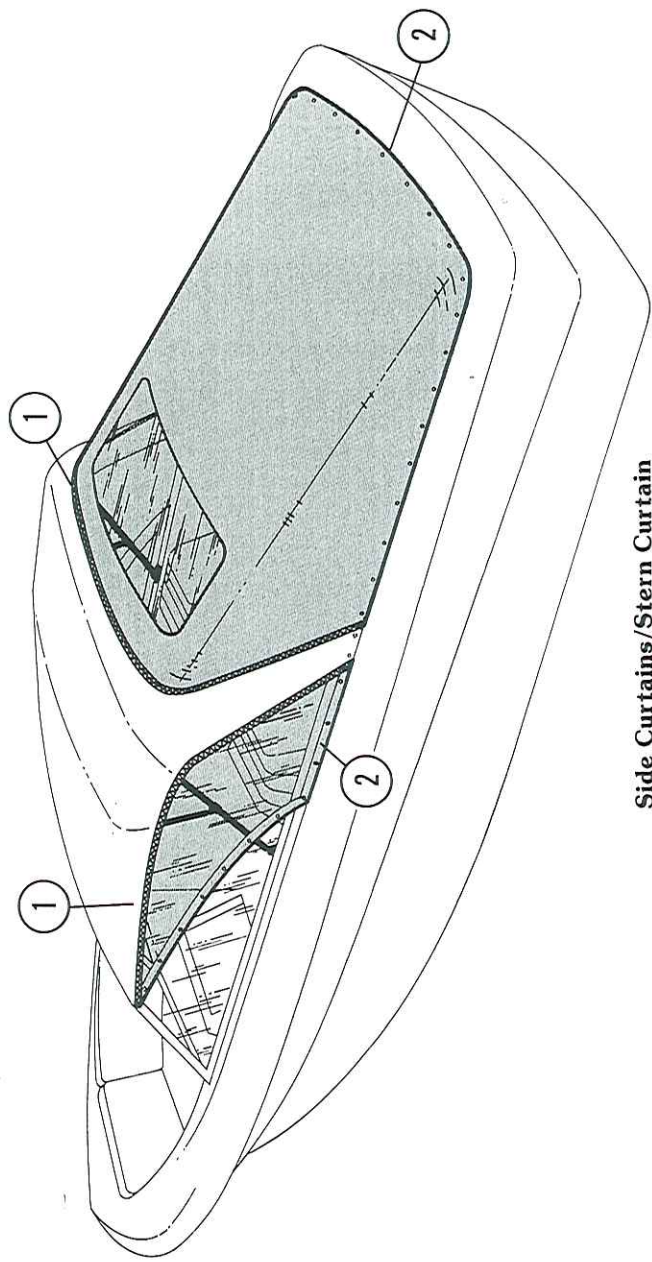

Side Curtains/Stern Curtain  
Figure #2

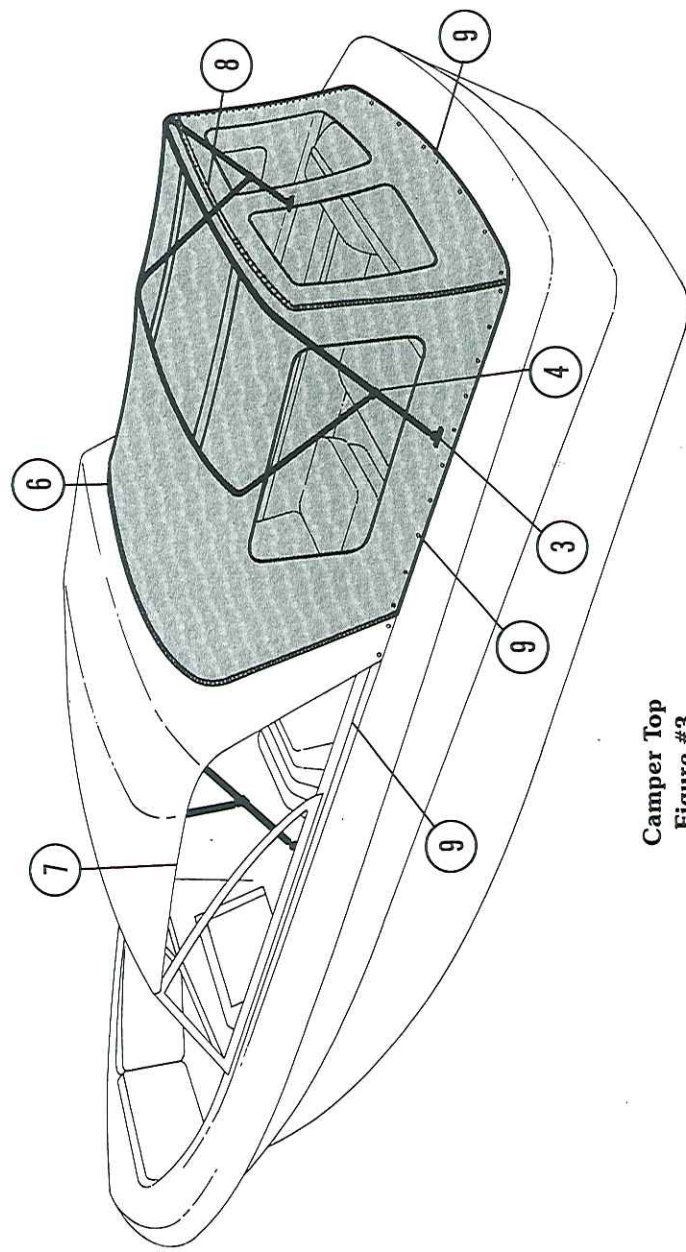

Camper Top  
Figure #3

8. Zip aft curtain to "Camper Top", starting at the center rear of the curtain and working forward evenly.
9. Snap side, aft curtains and camper top to deck, working forward evenly.

**e. Bimini Top — optional (See Figure 4)**

1. Due to the length of the bows, there is no storage provided for the optional bimini top.
2. Attach top bow to top mount on each side of the boat.
3. Attach forward straps to the eyelets on the windshield.
4. Attach aft straps to eyelets on the deck aft of the windshield.
5. Adjust the straps as necessary for proper fit.

**WARNING: THE OPTIONAL "BIMINI TOP" IS FOR LOW SPEED OPERATION ONLY, (LESS THAN 15 MPH AIR SPEED). IF IT IS USED IN HIGHER AIR SPEED THAN 15 MPH, IT COULD COME LOOSE OR COMPLETELY OFF, CAUSING INJURY TO THE OCCUPANTS OF THE BOAT.**

**f. Bowrider Tonneau Cover - optional (See Figure 5).**

1. Open walk-thru doors.
2. Starting at bow and working aft, snap cover to boat.
3. Close windshield center door and snap the canvas to the underside of the door.
4. Walk-thru doors may be closed if desired.

**NOTE: For storage, we recommend an optional travel/mooring cover of duck canvas that has the ability to breath. Do not use convertible tops, side curtains, aft curtains, tonneau covers, etc. for long term storage. These tops were not designed for long term storage. Adequate ventilation is not possible and mold/mildew will form. For more information on appropriate covering for long term storage, please see your Cobalt Dealer.**

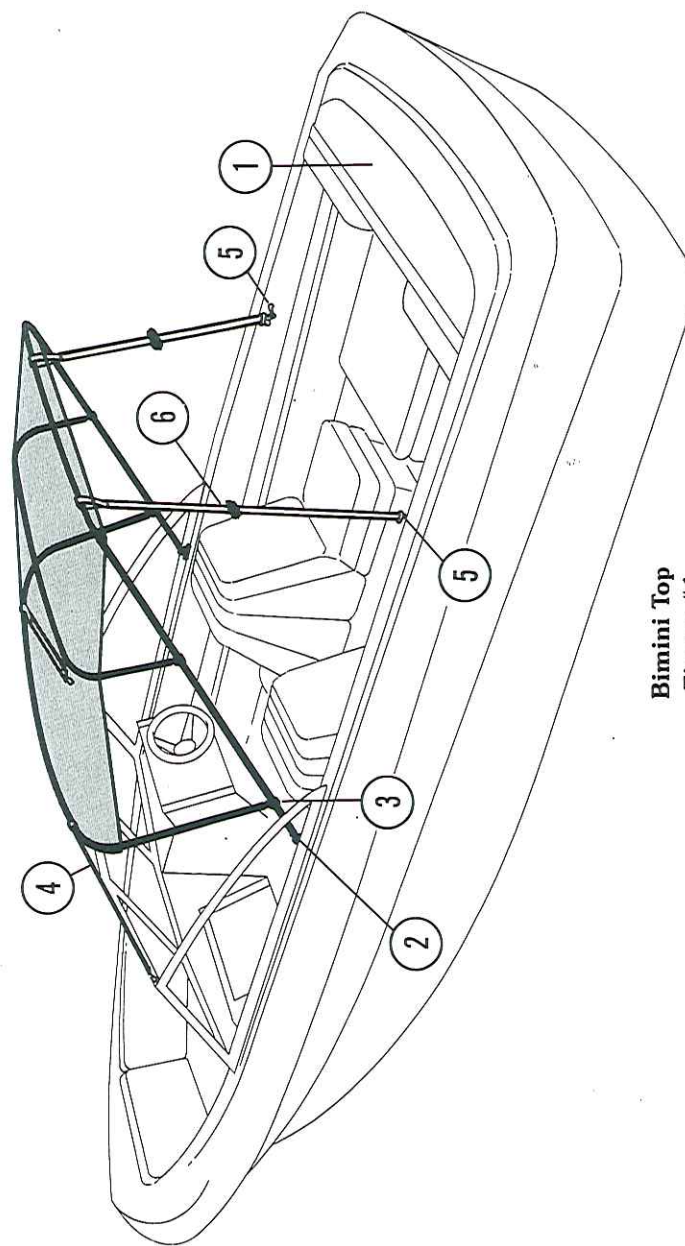

**Bimini Top  
Figure #4**

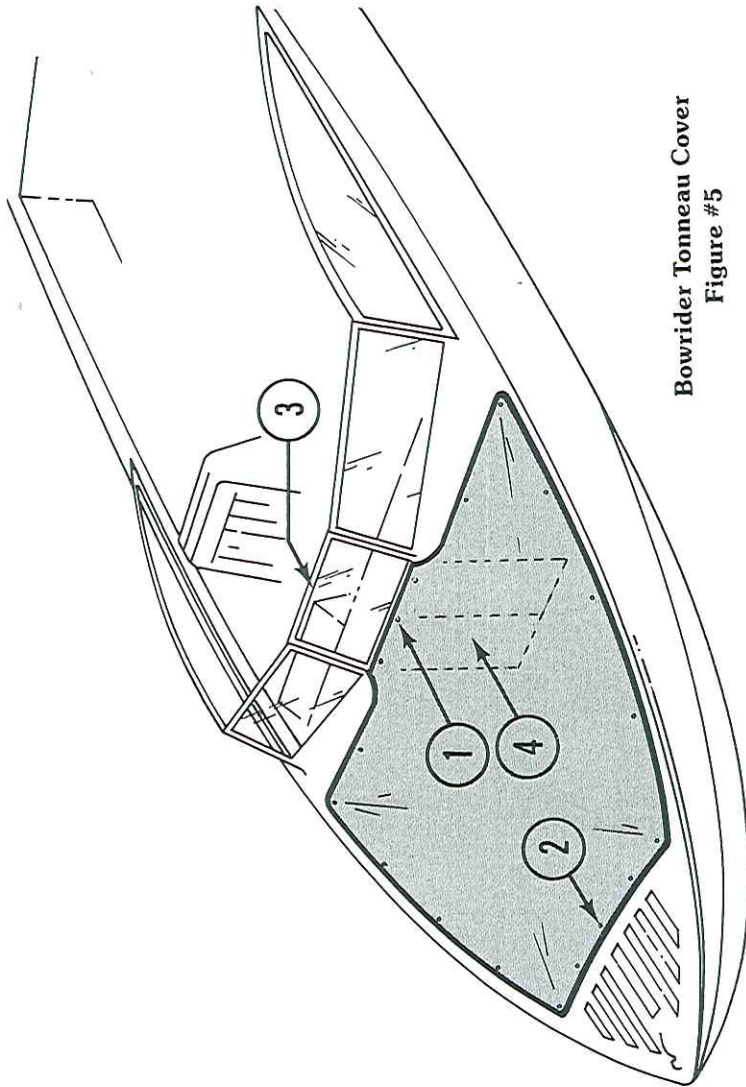

Bowrider Tonneau Cover  
Figure #5

**DANGER: DO NOT OPERATE YOUR COBALT WITH THE STERN CURTAIN OR CAMPER TOP CANVAS COMPLETELY CLOSED. THE COCKPIT MUST BE OPEN FOR FUEL COMPARTMENT VENTILATION.**

## 2. Stowage of the Canvas Top

The following is the recommended procedure for folding and storage of the top:

- a. Disconnect the tail panels from the side of the boat and allow them to hang free.
- b. Disconnect the top snaps from the windshield. (At this point, the two bows should still be separated.)
- c. Grasp the bows and fold them together. (Allow the canvas to gather between the bows.)
- d. Roll the canvas around the bows. (As you roll the canvas, assure its tightness and pull the side of the canvas to prevent wrinkling.)
- e. Slide the boot over the canvas and snap or zip.
- f. Remove the top from the "top bow extension legs" and stow the top in the "top storage compartment".
- g. Remove the extension legs and stow them in the "top storage compartment".

**NOTE: Make sure all canvas is completely dry before storage to prevent mildew.**

## 3. Canvas Maintenance

The fabric is first soaked (with occasional agitation) in a solution with the following proportions of Clorox and Ivory Flakes.

- 1/2 cup (4 oz.) Clorox
- 1/2 cup (4 oz.) Ivory
- 1 gallon lukewarm water

Let the fabric remain soaking in this solution until most of the stains disappear or for 20 minutes.

The fabric may be washed in an automatic washer on the COLD cycle using 2 cups (16 oz.) Clorox and one cup (8 oz.) Ivory Flakes. Line dry the canvas.

**NOTE: UNDER NO CIRCUMSTANCE are these fabrics to be put in HOT WATER. UNDER NO CIRCUMSTANCE are these fabrics to be run through the HOT drying cycle of an automatic dryer. FABRIC SHOULD BE LINE DRIED. UNDER NO CIRCUMSTANCE ARE THESE FABRICS TO BE STEAM PRESSED AT A DRY CLEANER.**

If leaking occurs after washing this may be the result of insufficient rinsing. If the fabric continues to leak after a very thorough rinsing, it may be necessary to apply a coat of silicone air drying water repellent. This should be done on a warm, sunny day, giving the application sufficient time to completely dry. Such silicone water repellents are available through Scotchgard or 3-M Company products.

#### 4. Seat Adjustment and Operation

##### A. Sleeper Seats

(See Figure 6)

The driver's seat is adjustable fore and aft. To attain desired position, lift the release handle (mounted under the forward lip of the driver's seat cushion), move seat, and release handle. Make sure handle retracts fully and seat is locked in place.

The passenger's seat is not adjustable.

To adjust the sleeper seat in the reclining position, grasp the forward edge of the seat cushion and lift until the mechanism releases. Extend the seat into the reclining position. On the driver's side, it will also be necessary to lift the release handle to slide the front of the mechanism to its most forward position. Reverse this procedure to replace in sitting position.

(See Figure 6)

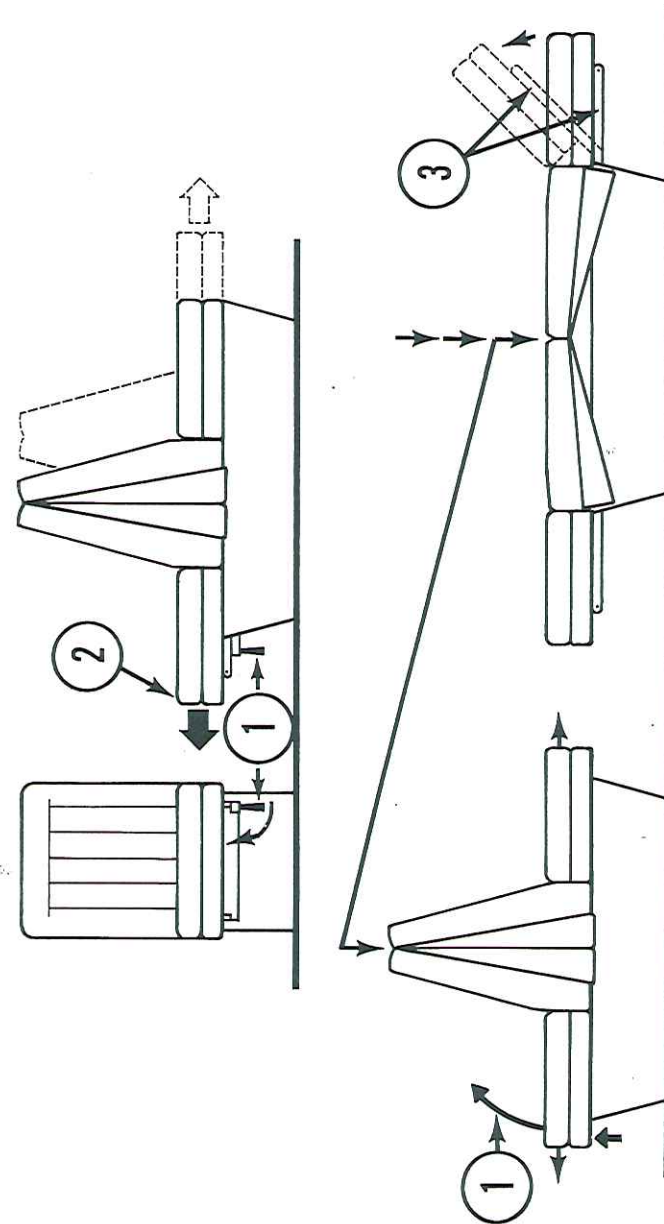

Sleeper Seat  
Figure #6

While in the reclining position, the after-most cushion can be raised and locked into a lounge position. To lock, press the support legs to an over center position. These are located under the cushion and are exposed when the cushion is raised. Reverse this procedure to return to normal position.

#### **B. Captains Chairs (Pedistal Mount)**

Both captain's chairs are adjustable. A lift handle is located under the seat. Lift the handle, move the seat to the desired position, and release the handle.

#### **C. Captains Chairs (Side Mount-21CC)**

##### **Pilot's Seat**

This seat is adjustable. A knurled knob is located outboard of the pilot's seat. Turn the knurled knob counter-clockwise, move seat to desired position, tighten the knob. The seat may be moved to its most aft position for standing while maneuvering at "dead slow" speed (engine at idle).

**WARNING: DRIVING WHILE STANDING UP IS AN EXTREMELY HAZARDOUS PRACTICE. DO NOT DRIVE WHILE STANDING AT SPEEDS GREATER THAN "IDLE SPEED".**

The passenger's seat is not adjustable.

#### **D. Rear Bench Seat Assembly**

##### **1. Engine Access**

The entire bench seat assembly lifts for engine access.

##### **2. Sleeper Position (Most Models)**

Release the slide bolts on the front of the seat cushion. This will allow the cushion to slide forward forming a berthing area.

**CAUTION: THE SEAT SHOULD BE IN THE UPRIGHT AND LOCKED POSITION WHEN THE ENGINE(S) ARE RUNNING.**

#### **5. Cuddy Cabin Access Doors**

##### **A. 21CC**

To open, unlock and raise the companionway hatch. With the doors open, the companionway hatch can be lowered to obtain

maximum visibility for the driver. The companionway hatch must be closed while boat is underway.

**WARNING: THE COMPANIONWAY HATCH MUST BE CLOSED WHILE THE BOAT IS UNDERWAY. LEAVING THE COMPANIONWAY HATCH OPEN WHILE UNDERWAY CAN OBSTRUCT THE DRIVER'S VISION CREATING A DANGEROUS SITUATION.**

#### **B. 223 CONDURRE**

The cabin door of the 223 has a strap provided to latch the door open. The door should be latched open while running the boat or premature wear can occur to the door frame and door lock assembly.

#### **C. 243/263 CONDURRE SLIDING DOOR**

To lock door, simply push in on lock assembly. To unlock, insert key and rotate lock a full turn and lock will release. A slide lock is provided to latch door in open or closed position. Make sure door is latched at all times while running or premature wear will occur.

#### **6. INSTRUMENT PANEL (please refer to pages 27-31)**

1. Clock — Electric
2. Fuel Gauge — shows approximate amount of fuel remaining in tank.
3. Voltmeter — shows the condition of charge in the battery. It only indicates while the ignition is in the "ON" position. With the engine at idle or not running, it may show as low as 10 to 12 volts. With the engine running at cruising speeds and above, it should show 12 to 14 volts.
4. Speedometer (Miles Per Hour)
5. Rudder Indicator — shows position of drive unit in relation to the center line of the boat.
6. Tachometer(s) — (Revolutions Per Minute)  
In twin engine installations, it is very unusual for both engines to indicate exactly the same. The reasons for this are:

- A. The power steering pump is on one engine only. This pump will normally slow the engine approximately 150 RPM at maximum throttle setting.
- B. Engine tune. It is very difficult to tune two engines identically and therefore the top RPM may vary.
- C. Propellers. If either propeller is dented or the blades are slightly damaged, this may cause a difference in RPM readings.
- D. The tachometers, themselves, may indicate a slight difference.

Summary — A slight difference of 50-200 RPM is normal at top RPM. If more difference is noted, check with your Cobalt dealer.

#### 7. Oil Pressure Gauge(s)

Pressure can vary according to type of engine. It is normal for a hot engine to have low pressure at idle, (depending on type of oil, pressure may drop as low as 10 PSI at idle).

Please consult the engine owners manual supplied with your boat concerning the oil pressure the engine in your boat should attain.

#### 8. Temperature Gauge(s)

Temperature may fluctuate slightly while running. Maximum temperature may vary depending on type of engine.

**WARNING: SHOULD WATER TEMPERATURE REACH 180 DEGREES FAHRENHEIT, YOUR ENGINE IS OVERHEATING AND SHOULD BE CHECKED IMMEDIATELY FOR PROBABLE CAUSE.**

- 9. Trim Gauge(s) — Shows the position of the drive unit(s) in reference to the bottom of the boat.
- 10. Horn Button — The horn, itself, is located under the deck on starboard side.
- 11. Lighter.
- 12. Bilge Blower Indicator — Red light indicates when bilge blower is operating.

- 13. Bilge Pump Indicator — Red light indicates when bilge pump is operating.
- 14. Interior Light Indicator — Red light indicates when interior lights are on.
- 15. Dash Light Indicator — Red light indicates when dash instrument lights are on.
- 16. Exterior Light Indicator — Red light indicates when navigation or anchor light is on.
- 17. Two Position Switch — Controls equipment as labeled.
- 18. Three Position Exterior Light Switch
  - Up position — navigation (running) lights, bow light and stern light.
  - Center position — off.
  - Down position — stern light only.

**WARNING: NEVER OPERATE YOUR BOAT AT NIGHT WITHOUT ALL OF THE REQUIRED LIGHTS OPERATING. (THIS INCLUDES BOW LIGHT AND STERN LIGHT.)**

- 19. Circuit Breakers
  - Push to reset if necessary. If the button continues to pop out, consult your Authorized Cobalt Dealer.
- 20. Ignition Key Switch
- 21. Indicator Light — For auxiliary equipment.
- 22. Low Fuel Indicator — Will momentarily light when ignition is first turned on. It will indicate with approximately 1/8 tank or less of fuel.
- 23. High Temperature Indicator — Will momentarily light when ignition is first turned on. It will indicate when engine temperature exceeds approximately 170 degrees.
- 24. Low Oil Pressure Indicator — Will momentarily light when ignition is first turned on, then go off. If the engine is not started, and the ignition key is left on, it will indicate after approximately 30 to 60 seconds (warm up). It will immediately indicate when oil pressure drops below 5 - 7 lbs.

**NOTE:** Many Chevrolet V-8 engines will idle when hot with pressure in the 5-7 pound range which will make the indicator light flicker slightly. This is normal. If the light indicates steadily, have your dealer check the system before further use.

**NOTE:** Items 22 - 24 are dealer adjustable to suit your individual needs.

25. Low Voltage — Will momentarily light when ignition is first turned on. It will indicate if the electrical system drops below 10.8 volts. If the engine is not running with the ignition on, or at a dead idle, and you have many electrical items turned on such as lights, blower, pump, etc., the light may indicate. If the engine is accelerated above approximately 1500 RPM, the light should go off after a few seconds. If it does not, please consult your Authorized Cobalt Dealer.

## 7. Engine Control

### Single Engine Models (except 243 and 263)

The engine controls shifting, throttle and in most cases incorporates the power trim control which is covered in another section entitled "Power Trim".

**NOTE:** We cannot overemphasize the importance of proper use of the throttle/shift control, especially from the standpoint of safety. Please consult the engine owner's manual supplied with your new Cobalt or consult your Authorized Cobalt Dealer for specific instructions about your throttle/shift control.

The following are general instructions:

### SIDE MOUNT CONTROL

The engine will start only in neutral. To move handle from neutral position squeeze the button on the handle and move handle. Moving handle forward engages forward gear initially.

Continuing forward movement will advance throttle. Moving handle aft engages reverse gear initially. Continued aft movement will advance throttle.

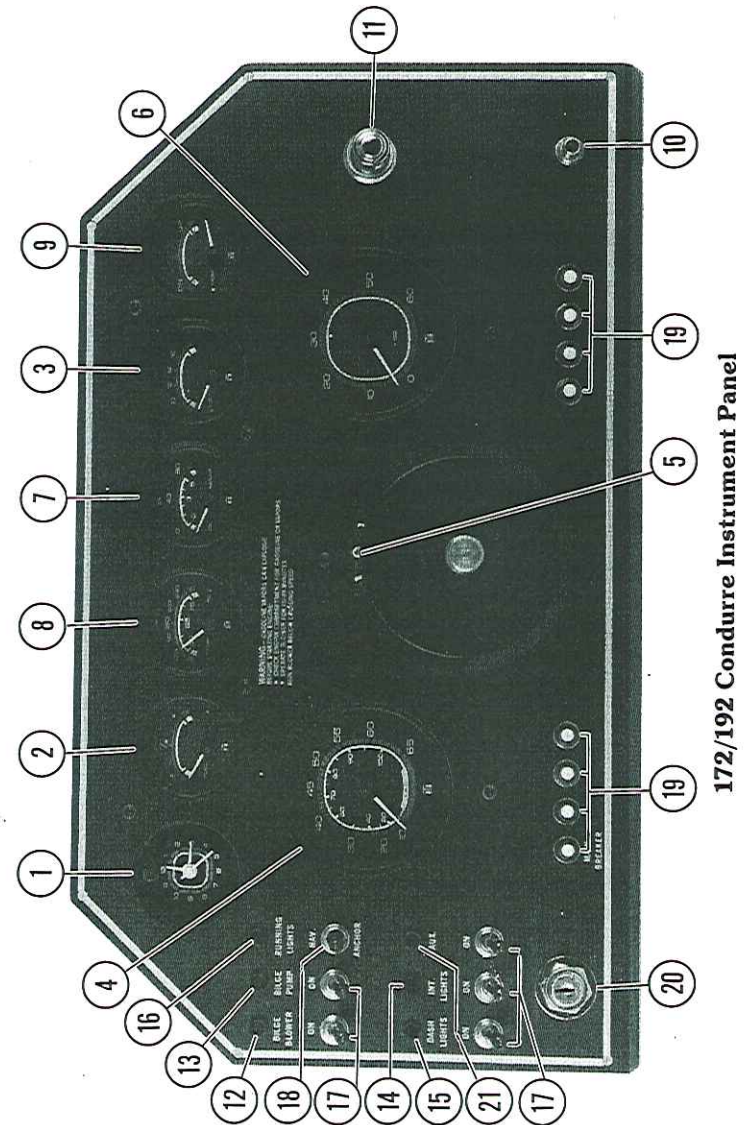

172/192 Condurre Instrument Panel

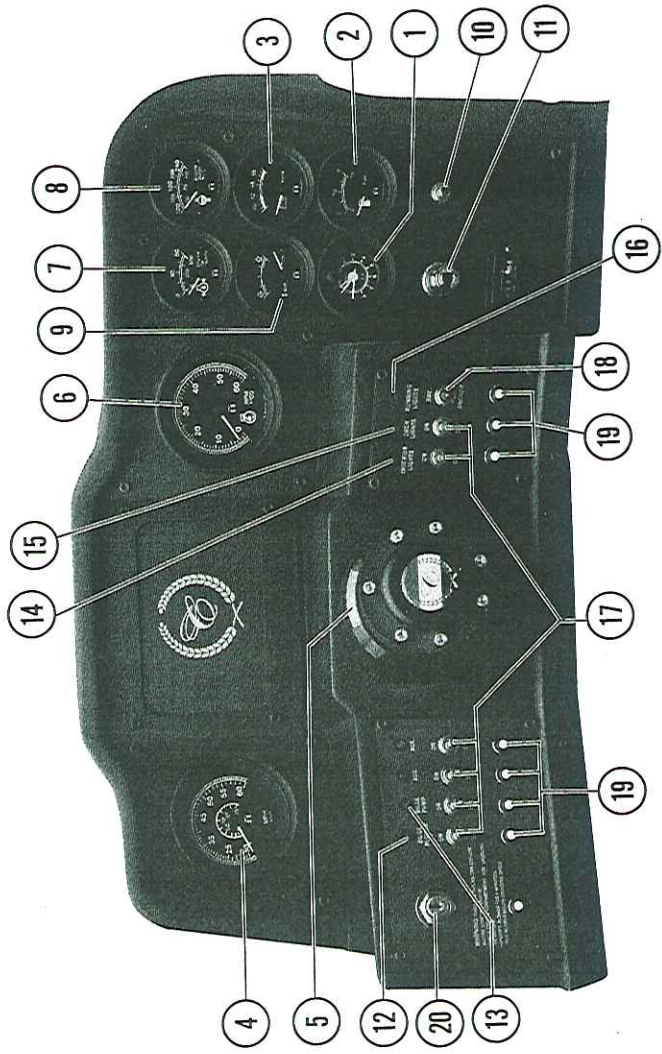

Condurre 202/203 Instrument Panel

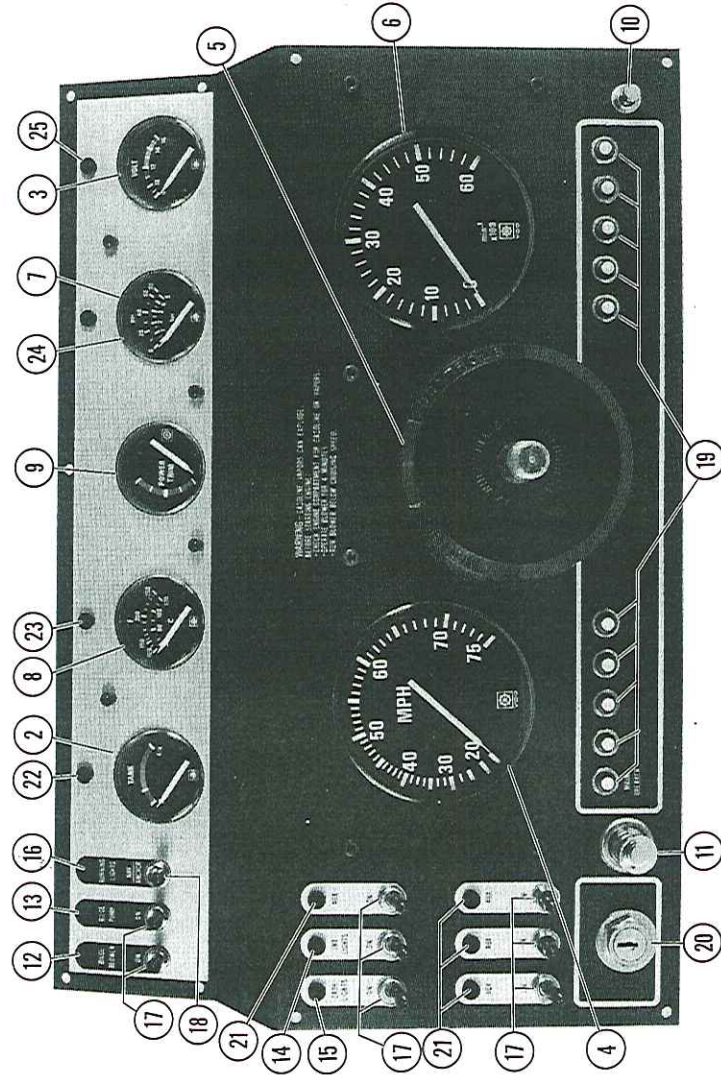

222, 223, 243 Condurre  
263 Condurre

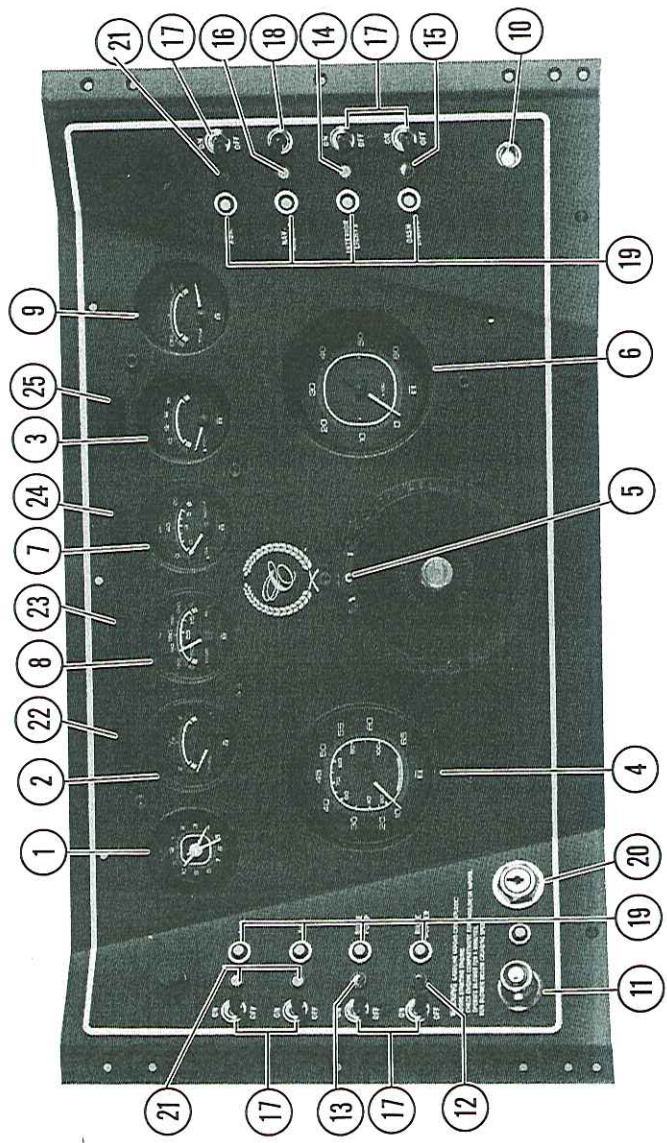

19BR Instrument Panel

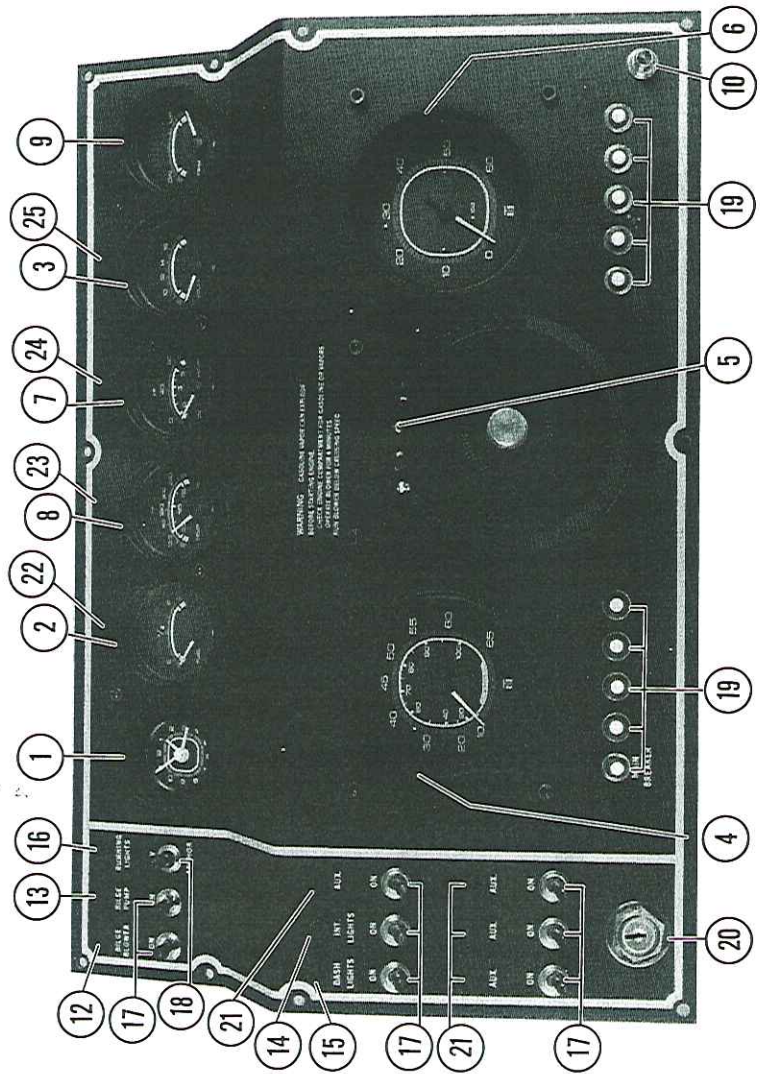

21BR, 21CC Instrument Panel

Cold Starting — While handle is in the neutral position, depress button in the center of the bottom of the handle and move forward. Please consult the engine owner's manual.

**WARNING: JAMMING THE THROTTLE INTO THE FORWARD OR REVERSE POSITION CAN CAUSE A SUDDEN, UNCONTROLLABLE BURST OF SPEED. DO NOT JAM THE THROTTLE LEVER FORWARD OR BACKWARD.**

#### **BINNACLE MOUNT CONTROL**

The engine will start only in neutral. Moving handle forward will engage forward gear. Moving handle aft will engage reverse gear. Continued movement in either direction past gear engagement will advance the throttle.

In twin engine models, the handles may be used as one to control both engines at the same time or independently to advance the throttle of one engine more than the other. It is also possible to shift one engine in forward and the other in reverse for maneuvering at "dead slow" speeds (idle).

**WARNING: JAMMING THE THROTTLE INTO THE FORWARD OR REVERSE POSITION CAN CAUSE A SUDDEN, UNCONTROLLABLE BURST OF SPEED. DO NOT JAM THE THROTTLE LEVER FORWARD OR BACKWARD.**

#### **KIEKHAEFER CONTROL (OPTIONAL)**

The optional Kiekhaefer Control (243 and 263 only) is a two lever control using separate levers for the throttle and shift functions. The control does provide start in neutral only protection but does not provide protection against shifting at above idle speeds. Great caution must be used when using this control. Only shift with the engine at a dead idle (700 RPM or less). Shifting above dead idle (either into or out of gear) can cause premature wear of the shift mechanism in your stern drive assembly. It also can create a safety hazard condition. Do not shift your Kiekhaefer controlled Cobalt above a dead idle position.

**WARNING: SHIFTING THE SHIFT LEVER AT ANY ENGINE SPEED ABOVE DEAD IDLE (700 RPM OR LESS) CAN CAUSE SUDDEN, UNCONTROLLABLE BURSTS OF SPEED.**

#### **8. Steering System**

The steering system in your Cobalt is the finest available in the boating industry today. It is a mechanical system, with power assist in all installations.

##### **Steering/Propeller Torque**

Steering or propeller torque is always present in any drive system. In some systems, it is more noticeable than in others. Your boat has power steering and you should not encounter this torque to any significant degree. If you encounter movement in the steering wheel when released, please check with your dealer. It may be necessary to adjust the power steering assembly or torque tab on the drive unit. These adjustments should only be made by a qualified service person. The steering system in your Cobalt is one of the most important systems and should be checked on a regular basis by an Authorized Cobalt Service Dealer for proper operation.

##### **Wandering/Fishtailing**

Wandering is a characteristic of all deep vee bottom boats at slow speed. There is no cure for wandering, however, a very basic operational technique can be applied which will minimize this characteristic. If the steering wheel is moved back and forth to compensate for wandering, invariably, the situation will be accentuated. If the steering wheel is left in a centered position, the boat will wander back and forth slightly, however, the overall course of the boat will be a straight one.

**WARNING: THE STEERING IS THE MOST IMPORTANT SYSTEM IN THE ENTIRE BOAT FROM A SAFETY STANDPOINT. HAVE THIS SYSTEM INSPECTED AND MAINTAINED ON A FREQUENT, PERIODIC BASIS BY A QUALIFIED SERVICE TECHNICIAN.**

## 9. Power Trim

### General

#### Single Engine

The power trim changes the drive unit angle in reference to the transom of the boat. Regardless of engine type, a few basic operating techniques should be applied.

1. The drive unit should be lowered fully prior to initial acceleration.
2. After the boat has attained planing speed (18-24 MPH), the trim should be raised for maximum speed and handling characteristics.
3. If the trim is raised too high, porpoising (bouncing) and cavitation (propeller slippage) can occur.
4. It will be necessary to readjust the trim angle as boat speed changes and the attitude of the boat changes.

#### Twin Engine

Your power trim is controlled by two (2) switches mounted on the engine control console. For general operating characteristics, please refer to the power trim, "Single Engine" section. The basic operating techniques remain the same for twin engines as for single engines.

The power trims may be operated simultaneously as one unit and will have the same effect as a single engine power trim system. In addition to this, the power trims, like the throttle controls, may be operated independently of each other. This will enable you to correct for side to side trim by raising or lowering one of the drive units independently of the other. For example, if the boat were leaning to the starboard side, it would be possible to compensate by raising the port drive unit slightly higher than the starboard unit. Conversely, if the port side of the boat were down, it would be possible to compensate for this by raising the starboard drive unit higher than the port drive unit. It is important to remember that correcting for side to side listing or lean can be compensated for only when the boat is on plane, above 18 to 24 MPH. Once the list or lean has been eliminated, the drive units can be raised or lowered together as one without a significant change in the side to side position of the boat.

**NOTE: Do not operate engine(s) with the drive(s) tilted.  
See your engine owner's manual.**

## 10. Warning Labels

Your Cobalt has several warning labels displayed to point out safety hazards. The areas are as follows:

- a. Boarding Ladder/Swim Platform  
"WARNING: Under no circumstances should anyone be allowed to enter or exit your Cobalt from the boarding ladder or swim platform while engine is running."
- b. Engine Flame Arrestor  
"Leaking fuel is a fire and explosion hazard. Inspect fuel system regularly. Examine fuel tank for leaks or corrosion at least annually."
- c. Dashboard  
"Operate Bilge Blower at least two minutes before starting engine. Run continuously during starting and below cruising speeds."
- d. Windshield Wing, Driver's Side Cobalt Check List  
For maximum enjoyment and safety, check each of these items BEFORE you start your engine:
  - DRAIN PLUG (Securely in place?)
  - LIFE-SAVING DEVICES (One for every person on board?)
  - STEERING SYSTEM (Working smoothly and properly?)
  - FUEL SYSTEM (Adequate fuel? Leaks? Fumes?)
  - BATTERY (Fully charged? Proper water level?)
  - ENGINE (In neutral?)
  - CAPACITY PLATE (Are you overloaded?)
  - WEATHER CONDITIONS (Safe to go out?)
  - ELECTRICAL EQUIPMENT (Lights, horn, pump, etc.?)
  - EMERGENCY GEAR (Fire Extinguisher? Bailer? Paddle? Anchor and Line? Signalling Device? Tool Kit? Etc.?)
- e. RECOMMENDED SAFETY RULES
  - REMAIN SEATED WHILE UNDERWAY.
  - AVOID USING REAR PAD OR SUNDECK WHILE ENGINE IS RUNNING.

- DO NOT USE BOARDING LADDER WHILE ENGINE IS RUNNING.
- TURN OFF ENGINE AND ALL ELECTRICAL SYSTEMS WHILE RE-FUELING.
- TURN OFF ENGINE(S) WHEN SWIMMERS ARE NEAR BOAT.

**WARNING: MANEUVERABILITY ABOVE 50 MPH IS LIMITED. SUDDEN TURNS MAY CAUSE LOSS OF CONTROL. (NOT ALL BOATS ARE REQUIRED TO HAVE THIS DECAL).**

## 11. High Speed Operation

### a. Maneuverability

When operating any boat at high speed, a great deal of caution must be exercised. This is particularly true during turns. Gradual turns can be completed at high speed by a competent driver but it must be emphasized that sudden turns at any speed and particularly at high speed can be especially dangerous. It is possible to throw passengers from their seats and even from the boat if caution is not exercised. Remember, common sense is the rule for safe boating.

### b. Wake Jumping

Your Cobalt is not designed for wake jumping. When crossing another boat's wake, it is recommended that you throttle back to prevent your boat from leaving the water. Wake jumping is very dangerous. It is possible for the boat to re-enter the water on its side, transom, or bow. In any of these instances, you and your passengers could suffer serious injury. Also, damage to the boat could take place causing a hazardous condition.

## 12. Lifting Rings On Your Cobalt (See Fig. 7) (19BR, 21BR, 21CC)

The lifting rings on your Cobalt have been strength tested by an independent testing laboratory and are found to be capable of withstanding almost 2½ times the weight of the boat.

Keep in mind however, that there is a proper way to lift your Cobalt. Lifting pressure should always be vertical from the rings. Improper lifting could cause damage. If only one hoist is used, a spreader bar must be employed to avoid side strain on the rings.

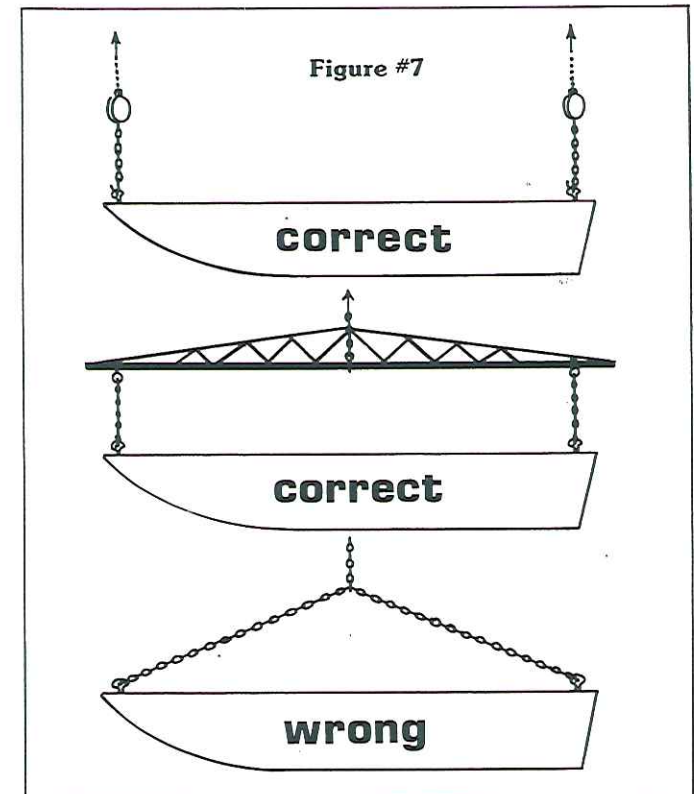

**CAUTION: LIFT RINGS MUST NOT BE USED FOR STORAGE. AFTER YOUR COBALT IS LIFTED INTO POSITION, SUPPORT MUST BE PLACED UNDER THE HULL AND ALL OF THE WEIGHT REMOVED FROM THE LIFTING RINGS. FOR FURTHER INFORMATION, PLEASE CONTACT YOUR COBALT**

**DEALER. FIGURE 8 ILLUSTRATES THE CORRECT AND INCORRECT HOOK-UP FOR LIFTING.**

### **13. Trash Receptacle**

#### **19BR**

To remove this compartment, first open fully. Then lift up and pull out from the bottom. After it clears the lower lip, lower and remove. To reinstall, reverse the procedure.

#### **21BR**

To remove, open hanging locker door and release the expansion cord from the back of the trash receptacle. The receptacle can then be removed.

#### **21CC, CS23, Condesa, 23BR**

Your Cobalt is equipped with a trash receptacle. It is located under the driver's captain's chair. To release, pull receptacle open.

### **14. Fold Down Boarding Ladder**

**THIS LADDER MUST ONLY BE USED WHILE ENGINE IS OFF.** (See warning label section). To lower, unsnap securing strap, and lower. Be sure ladder is raised and secured prior to starting engine. Caution should be used while using this ladder, in that any substance can be slippery when wet.

**WARNING: DO NOT USE BOARDING LADDER WHILE ENGINE IS RUNNING.**

**CAUTION: THE STERN DRIVE UNIT HAS MANY SHARP EDGES, ESPECIALLY THE PROPELLER. EXERCISE CAUTION WHEN NEAR THE STERN DRIVE UNIT.**

### **15. Water Ski Towing**

If your Cobalt has lifting rings, the ring may be used for water skiing lines. In other models, the ski tow hook may be used for one or more lines. In all models, the transom eyes or stern cleats may be used.

**WARNING: WHENEVER A SKIER OR SWIMMER IS**

**CLOSE TO THE BOAT, SHUT OFF THE ENGINE TO PREVENT SERIOUS INJURY.**

**CAUTION: THE STERN DRIVE UNIT HAS MANY SHARP EDGES, ESPECIALLY THE PROPELLER. EXERCISE CAUTION WHEN NEAR THE STERN DRIVE UNIT.**

### **16. Deck Hatch**

#### **21CC, 223, 243, 263**

The deck hatch is manually operable. To open, simply release the one or two hasps on the forward edge of the hatch, make sure the support bracket adjusters are loose, and raise the hatch to the desired position and secure the adjusters.

**CAUTION: DO NOT USE A RAISED HATCH FOR A SUPPORT OR HAND HOLD WHILE ON THE DECK.**

### **17. Engine Accessibility**

#### **Standard Interior**

#### **172, 192, 19BR, 21BR, 22CC, 202, 203, 222**

1. Open engine box by using teak handle. **Do not lift** on the underside of the jump seat cushion. When closing the motor box, do not allow the box to "slam shut".

#### **Condurre 223, 243, 263**

Motor box lid is electrically controlled. Make sure battery switches are turned on and operate the appropriate switch on the dash. If the battery is dead, you can lift the hatch by hand (the hatch is quite heavy and caution should be exercised that it does not fall on hands or arms). The electric mechanism automatically disconnects.

#### **Optional Interiors**

#### **Sundeck — 19BR, 192, 202, 203**

Open engine box by using teak handle. Do not lift on the underside of the seat cushion. When closing the motor box, do not allow the box to "slam shut".

#### **Sundeck — 21BR, 222**

Open sundeck lid. For further access, open the slide bolt on each side panel and open bi-fold door for access to the sides of the engine.

## 18. Dual Batteries and Dual Battery Switches (Twin Engines)

Your twin engine Cobalt is equipped with two batteries and two battery switches. The basic purpose of this system is to enable you to allow either engine to charge either/or both batteries. It also enables you to isolate one battery from the entire electrical system while using the other. From a safety standpoint, this will prevent you from accidentally running both batteries down when using electrical equipment without operating the engines.

- a. Line up the starboard engine battery switch to "position 1" and the port engine battery switch to "position 2". (Normal Operation)
- b. Starboard engine battery switch to "position 2" and the port engine battery switch to "position 1". (Normal Operation)
- c. If you want one engine to charge both batteries, place that engine's battery selector switch to the "all" position and the other engine's selector to "off". (Emergency Only)
- d. If you want both engines to charge one battery, place both battery switches on either "position 1" or "position 2", depending on which battery you want charged. (Emergency Only)
- e. If you want both engines to charge both batteries, put both battery switches in the "all" position. (Emergency Only)

To isolate the batteries from the electrical system for storage purposes or for charging from an external battery charger, place both switches in the "off" position.

**CAUTION: IF BOTH ENGINES ARE ALLOWED TO CHARGE BOTH BATTERIES AT ALL TIMES, AN OVERCHARGED CONDITION OF ONE OF THE BATTERIES OR BOTH CAN EXIST. UNDER NORMAL OPERATING CIRCUMSTANCES, IT IS IMPORTANT THAT EACH ENGINE BE SELECTED TO ITS OWN BATTERY.**

**WARNING: BATTERY ACID CAN CAUSE BLINDNESS IF SPLASHED IN EYES, BURNING OF SKIN AND SEVER GASTROINTESTINAL DAMAGE IF INGESTED. AVOID CONTACT WITH BATTERY ACID. USE EXTREME CAUTION.**

## 19. Optional Equipment

### a. Swim Platform

To avoid damage to the optional swim platform, always be sure the outdrive unit is in the straight ahead position before tilting the outdrive all the way up. (Single Engine Only)

**WARNING: MAKE SURE THE ENGINE IS SHUT OFF BEFORE USING SWIM PLATFORM.**

### b. Camper Top

See Section IV Boat Operation 1. Canvas.

### c. AM/FM Stereo Cassette

There are separate instructions in the owner's packet that give specific instructions for operation.

### d. Remote Control Spotlight

1. Has both flood and spot beams controlled by a three position switch on the spotlight control panel.

**NOTE: The spotlight control panel has two (2) fuses behind it accessible by removal of the panel itself. The fuses are for the bulb and the spotlight motor.**

2. Rotates more than 360 degrees and will travel up and down by using "joy stick" control.
3. Speed at which spotlight moves is controlled by the black knurled knob.

### e. Docking Lights

Controlled by "aux" switch on dash.

### f. Trim Tabs

The trim tabs are a separate system in themselves and are not to be used in lieu of the engine power trim system.

1. Before accelerating, make sure the tabs are both fully raised.
2. Do not use the tabs until the boat has reached the desired speed and the power trim has been adjusted to the proper setting.
3. Operate only one tab at a time and in small increments. As the tab takes effect, you will notice it causes the boat to veer off course slightly. Correct for this as it happens. In other words, it will be necessary to use the trim tab and correct the steering simultaneously.

Basic operating techniques — Bow high attitude

1. Make sure both tabs are fully raised.
2. Lower both tabs simultaneously for approximately five seconds.
3. Accelerate the boat to planing speed and see if the desired effect is attained.
4. If not, raise or lower both tabs until desired attitude is obtained.
5. After desired attitude is obtained, one trim tab may be adjusted independently of the other to compensate for listing.
6. Make it a habit to raise both tabs each time the boat is slowed to less than planing speed.

**NOTE: If in doubt, raise the tabs completely and start over again.**

g. Extra Battery and Switch (Single Engine)

This option gives you the ability to isolate the entire boat from the batteries, and switch to either or both batteries. Under normal situations, the switch should be in "position 1" or "position 2" rather than the "all" position. This will keep one battery in reserve should the other fail. Battery selection should be made with engine off only. We recommend alternating batteries on a daily basis.

h. Portable Head

Please consult the owner's manual supplied with the head for proper operation.

## V. PROPELLERS AND PROPELLER CHART

### Propellers — General

Nothing is more important to the proper performance of your boat than the condition of the propeller(s). Even minor damage (often invisible to the naked eye) can adversely affect the boat's performance. Common symptoms of damage to propellers are a sudden drop in RPM, vibration or sudden loss of speed.

A propeller is measured by two dimensions: 1) the diameter; and, 2) the pitch. The diameter is determined by measuring the distance from the center of the propeller to the tip of one blade and multiplying that figure by two. Pitch is expressed in the number of inches a prop will advance in a solid medium in one revolution.

Operational characteristics of your boat, including its speed, may change due to several factors: atmospheric conditions; additions of extra equipment and accessories or passengers; marine growth on the bottom; and, engine condition. Other factors include damage to the prop(s), tides, water temperature and direction of wind. Some of these factors are directly correctable by repair or maintenance. Others are beyond human control. A few which may be considered permanent operating conditions may be compensated for by a change in prop(s). Such a change should not usually be undertaken without the advice of your dealer. Unless you are prepared to spend much time and money on hit and miss methods of prop selection, it is strongly recommended that you talk with your Cobalt Dealer.

**CAUTION: INCORRECT PROPELLER APPLICATION CAN CAUSE ADVERSE HANDLING CHARACTERISTICS. DO NOT CHANGE TYPE OR SIZE OF PROPELLER WITHOUT CONSULTING YOUR COBALT DEALER!**

### Stainless Steel

For the ultimate in top speed, stainless steel propellers will increase top speed by two to four MPH. However, they will do so at the sacrifice of some of the pulling power for water skiing and heavy loads. Stainless steel propellers should only be used when additional speed is desired. Under normal usage, aluminum propellers will give you the best overall performance. Keep in mind that if hitting a submerged object, aluminum will bend easier than stainless, absorbing most of the shock and help protect the stern drive. Stainless steel

may not bend and transmit the shock into the drive which could cause internal drive damage. For further information, please consult your Cobalt dealer.

### Pulling Power

If you need extra pulling power, you can obtain this by decreasing the pitch of your propeller(s) by two degrees. This will not endanger the engine or drive unit as long as the manufacturer's recommended top RPM's are not exceeded. Generally, an aluminum propeller will out-pull a stainless steel propeller of the same pitch size.

## 1989 PROP CHART ALUMINUM

	172/192	19BR	202/203	21's	222/223	243	263
4.3 175 MERC V-6	13 <sup>3</sup> / <sub>4</sub> x 21C 48-78122A40	N/A	N/A	N/A	N/A	N/A	TWIN ONLY NOT TESTED
3.7 180 MERC 4 cyl.	N/A	N/A	N/A	N/A	N/A	N/A	TWIN ONLY NOT TESTED
4.3 205 MERC V-6	13 <sup>3</sup> / <sub>4</sub> x 21C 48-78122A40	N/A	N/A	N/A	N/A	N/A	TWIN ONLY NOT TESTED
5.7 260 MERC V-8	N/A	13 <sup>3</sup> / <sub>4</sub> x 21C 48-78122A40	13 <sup>3</sup> / <sub>4</sub> x 21C 48-78122A40	14 x 19C 48-78120A40	13 <sup>3</sup> / <sub>4</sub> x 21C 48-78122A40	14 x 19C 48-78120A40	NOT TESTED NOT TESTED
7.4 BRAVO MERC V-8 (330)	N/A	N/A	N/A	MIRAGE ONLY	MIRAGE ONLY	MIRAGE ONLY	MIRAGE ONLY
7.4 MAG BRAVO V-8 (365)	N/A	N/A	N/A	N/A	MIRAGE ONLY	MIRAGE ONLY	MIRAGE ONLY
4.3 205 VOLVO V-6	B-7 853637-7	N/A	N/A	N/A	N/A	N/A	TWIN ONLY NOT TESTED
5.7 271 VOLVO V-8	N/A	B-7 853637-7	B-7 853637-7	B-6 853636-9	B-6 853636-9	B-6 853636-9	NOT TESTED
4.3 205 YAMAHA V-6	NOT TESTED	N/A	N/A	N/A	N/A	N/A	STAINLESS ONLY
5.7 260 YAMAHA V-8	N/A	STAINLESS ONLY	N/A	STAINLESS ONLY	STAINLESS ONLY	STAINLESS ONLY	STAINLESS ONLY

NOTE: All Bravo Powered Cobalts are Standard Equipped with Merc Mirage Props  
All Yamaha Powered Cobalts are Standard Equipped with Yamaha Stainless Props

## 1989 PROP CHART STAINLESS

	172/192	19BR	202/203	21's	222/223	243	263
4.3 175 MERC V-6	13 <sup>3</sup> / <sub>4</sub> x 21C 48-16318A5	N/A	N/A	N/A	N/A	N/A	TWIN ONLY NOT TESTED
3.7 180 MERC 4 cyl.	N/A	N/A	N/A	N/A	N/A	N/A	TWIN ONLY NOT TESTED
4.3 205 MERC V-6	13 <sup>3</sup> / <sub>4</sub> x 21C 48-16318A5	N/A	N/A	N/A	N/A	N/A	TWIN ONLY NOT TESTED
5.7 260 MERC V-8	N/A	13 <sup>3</sup> / <sub>4</sub> x 21C 48-16318A5	13 <sup>3</sup> / <sub>4</sub> x 21C 48-16318A5	14 x 19C 48-16316A5	13 <sup>3</sup> / <sub>4</sub> x 21C 48-16318A5	14 x 19C 48-16316A5	NOT TESTED
7.4 BRAVO MERC V-8 (330)	N/A	N/A	N/A	14 <sup>5</sup> / <sub>8</sub> x 23 MIRAGE 48-13704A40 (STD EQUIP)	14 <sup>5</sup> / <sub>8</sub> x 23 MIRAGE 48-13704A40 (STD EQUIP)	14 <sup>3</sup> / <sub>4</sub> x 21 MIRAGE 48-13702A40 (STD EQUIP)	15 <sup>1</sup> / <sub>4</sub> x 19 MIRAGE 48-13700A40 (STD EQUIP)
7.4 MAG BRAVO V-8 (365)	N/A	N/A	N/A	N/A	14 <sup>5</sup> / <sub>8</sub> x 23 MIRAGE 48-13704A40 (STD EQUIP)	14 <sup>3</sup> / <sub>4</sub> x 21 MIRAGE 48-13702A40 (STD EQUIP)	15 <sup>1</sup> / <sub>4</sub> x 19 MIRAGE 48-13700A40 (STD EQUIP)
4.3 205 VOLVO V-6	N/A	N/A	N/A	N/A	N/A	N/A	N/A
5.7 271 VOLVO V-8	N/A	N/A	N/A	N/A	N/A	N/A	N/A
4.3 205 YAMAHA V-6	NOT TESTED	N/A	N/A	N/A	N/A	N/A	TWIN ONLY NOT TESTED
5.7 260 YAMAHA V-8	N/A	13 <sup>3</sup> / <sub>4</sub> x 19 6G5-45974-01 .98 (STD EQUIP)	13 <sup>3</sup> / <sub>4</sub> x 19 6G5-45974-01 .98 (STD EQUIP)	13 <sup>3</sup> / <sub>4</sub> x 17 6G5-45978-01 .98 (STD EQUIP)	13 <sup>3</sup> / <sub>4</sub> x 19 6G5-45974-01 .98 (STD EQUIP)	13 <sup>3</sup> / <sub>4</sub> x 17 6G5-45978-01 .98 (STD EQUIP)	NOT TESTED

## VI. TECHNICAL INFORMATION

### 1. Engine Operation/Maintenance/Serviceing

Included with your owner's packet is your engine manual(s). This manual was prepared by the engine manufacturer and contains virtually everything you'll need to know concerning operation and care of your engine. Please read this manual thoroughly and become acquainted with this information.

It is advisable to maintain a service log to record service checks, such as oil changes, so you can determine when it's time for servicing.

### 2. The Break-In Period

We cannot stress enough, the importance of reading your engine manual(s) and following the manufacturer's instructions for breaking-in your engine(s).

### 3. Winterizing and Off-Season Storage

- a. Preparing for winter lay up is vital for the preservation of your Cobalt. In frigid zones, you must be particularly attentive to items that can be damaged by freezing. Freeze damage is not covered by warranty.
- b. Step by step instructions on what must be done to your engine(s) for winter storage is outlined in your engine manual(s). Follow these essential instructions carefully. This manual also details procedures for returning your engine(s) to service for in-season usage.
- c. Good storage is very important, be it indoors or outdoors. Proper storing or blocking is necessary to properly support the hull when stored dry. Most boat trailers provide sufficient support for long term storage.
- d. Provide adequate ventilation if canvas covered. Be sure there are openings at both ends so that a thru draft is created.
- e. Do not use convertible top, stern curtain, side curtains, cockpit tonneau cover, bow tonneau cover, camper top for storage. They will not provide ventilation nor are they designed to be waterproof. The only material that should be

used for storage is army duck canvas such as Cobalt's optional Travel/Mooring Cover. Cobalt also advises against the use of temporary poly covers such as shrink wrap covers unless adequate ventilation is supplied.

- f. Remove battery. Store on wooden shelf or wood base. Store in dry, covered place, charged to capacity and check it periodically during the off-season. Recharge monthly.

**WARNING: BATTERY ACID CAN CAUSE BLINDNESS IF SPLASHED IN EYES, BURNING OF SKIN AND SEVERE GASTROINTESTINAL DAMAGE IF INGESTED. AVOID CONTACT WITH BATTERY ACID. USE EXTREME CAUTION.**

- g. If you are able to obtain regular leaded fuel without alcohol, store your Cobalt with the fuel tank full. It is also advisable to add fuel preservative to your tank during winter months or any long periods of storage.

If you are using alcohol blended regular fuel and most of us are, it is desirable to have the fuel system drained completely. During storage, alcohol attracts water which can corrode aluminum parts such as fuel tanks, fuel pumps, carburetors, etc. It also can deteriorate flexible fuel lines between the fuel tank and fuel inlet of the engine.

**WARNING: YOUR FUEL SYSTEM SHOULD BE CHECKED BEFORE EACH OPERATION. AT LEAST ONCE A YEAR, HAVE A THOROUGH CHECK OF YOUR FUEL SYSTEM BY A CERTIFIED, COBALT SERVICE MAN. GASOLINE IS HIGHLY FLAMMABLE: EXTREME CAUTION SHOULD BE USED AT ALL TIMES.**

- h. It is vital that your Cobalt be stored with the bow slightly elevated; i.e., the same attitude as if the boat were floating at rest. If the boat is stored with the bow down, moisture will not be able to move to the engine bilge area and out of the boat. Mold and mildew may form as a result of the inability of moisture to escape. This can create structural damage to the

internal stringer system as well as cause mold and mildew.

- i. Remove drain plug from transom.

#### 4. Fuel Requirements

Marine engines are designed to be operated with regular, leaded fuel. As you know, the lead is being removed and alcohol is being substituted as an octane booster. Alcohol can have a detrimental effect on fuel lines, fuel tanks, fuel pumps and carburetors.

At Cobalt, we are most concerned with the safety aspect of the life of the fuel line between the fuel tank and the fuel inlet of the engine. This line is made of a synthetic, flexible material and although it is the best material available, alcohol can deteriorate it especially during periods of storage. For this reason, it is suggested that you have your Cobalt dealer inspect this fuel line at least annually and replace, if necessary.

The situation with fuels and the composition of fuel lines is changing very rapidly, therefore please keep in touch with your Cobalt dealer.

The performance of the engine may also be affected with the changing fuels. Please read your engine owners manual for recommended fuel usage.

**WARNING: YOUR FUEL SYSTEM SHOULD BE CHECKED BEFORE EACH OPERATION. AT LEAST ONCE A YEAR, HAVE A THOROUGH CHECK OF YOUR FUEL SYSTEM BY A CERTIFIED, COBALT SERVICE MAN. GASOLINE IS HIGHLY FLAMMABLE; EXTREME CAUTION SHOULD BE USED AT ALL TIMES.**

### 5. Trouble Check Chart

<b>Trouble</b>	<b>Possible Cause</b>	<b>Action</b>
Engine won't start	<ol style="list-style-type: none"> <li>1. Lack of Fuel</li> <li>2. Clogged anti-siphon valve</li> <li>3. Clogged fuel tank pick-up</li> <li>4. Clogged fuel filter</li> <li>5. Plugged fuel line or defective pump.</li> <li>6. Carburetor float valve stuck</li> <li>7. Damp spark plugs</li> <li>8. High tension leads wet and/or loose</li> <li>9. No spark</li> <li>10. No spark</li> </ol>	<p>Check fuel.</p> <p>See Authorized Cobalt Dealer.</p> <p>See Authorized Cobalt Dealer.</p> <p>See Authorized Cobalt Dealer.</p> <p>Fuel pump may be defective. Inspect pump sight glass for fuel leakage from fuel pump.</p> <p>See Authorized Cobalt Dealer.</p> <p>Tap float chamber with a screwdriver handle to free needle valve.</p> <p>Dry spark plug ceramic with clean, dry cloth.</p> <p>Dry and tighten connections at spark plugs, distributor and coil.</p> <p>Check for loose connections on coil.</p> <p>Check high tension lead on coil.</p> <p><b>WARNING: WHENEVER CHECKING FOR ELECTRICAL PROBLEMS USE EXTREME CAUTION. GASOLINE IS FLAMMABLE!</b></p>

<b>Trouble</b>	<b>Possible Cause</b>	<b>Action</b>
Starter won't crank engine	<ol style="list-style-type: none"> <li>1. Ignition Switch</li> <li>2. Throttle Position</li> <li>3. Dead battery</li> </ol>	<p>Check fuel supply for water contamination. If gasoline is old or if water is present, drain fuel tank and flush with fresh gasoline</p> <p><b>WARNING: GASOLINE IS FLAMMABLE USE EXTREME CAUTION WHEN HANDLING GASOLINE!</b></p> <p>If inoperative, see Authorized Cobalt Dealer.</p> <p>Check to see that remote control is in start position. Change position of throttle only slightly.</p> <p>Check level of electrolyte, disconnect battery. Charge battery.</p> <p><b>WARNING: BATTERY ACID CAN CAUSE BLINDNESS IF SPLASHED IN EYES; BURNING OF SKIN AND SEVERE GASTROINTESTINAL DAMAGE IF INGESTED. USE EXTREME CAUTION.</b></p>

<b>Trouble</b>	<b>Possible Cause</b>	<b>Action</b>
	<ul style="list-style-type: none"> <li>4. Battery connections loose or corroded</li> <li>5. Starter connections loose</li> </ul>	<p>Check for loose connections and corrosion. Clean connections and tighten.</p> <p>Check connections and tighten.</p> <p>If solenoid clicks when attempting to start engine, check battery connections. If condition persists, see your Authorized Cobalt Service Dealer.</p>
Engine runs erratically	<ul style="list-style-type: none"> <li>1. Automatic choke out of adjustment</li> <li>2. Water and/or dirt in fuel filter</li> <li>3. Fuel pump malfunction</li> <li>4. Fuel tank vent and line plugged</li> </ul>	<p>See your Authorized Cobalt Dealer</p> <p>Clean and inspect filter.</p> <p><b>WARNING: GASOLINE IS FLAMMABLE. USE EXTREME CAUTION.</b></p> <p>Check operation of pump.</p> <p>Replace fuel pump. See your Authorized Cobalt Dealer.</p> <p>Check for restriction in line and vent.</p> <p>Blow out line and vent.</p>
Engine vibrates	<ul style="list-style-type: none"> <li>1. Propeller condition</li> <li>2. Carburetor out of adjustment.</li> <li>3. Spark plug condition</li> </ul>	<p>Check for bent, broken or damaged propeller. Check for weeds on propeller or gearcase.</p> <p>See Authorized Cobalt Dealer.</p> <p>Check spark plug electrodes and ceramic.</p> <p>Clean and regap. Replace plugs, if necessary.</p>

<b>Trouble</b>	<b>Possible Cause</b>	<b>Action</b>
Engine runs but boat makes little or no progress	<ul style="list-style-type: none"> <li>4. High tension leads loose or deteriorated</li> <li>5. Incorrect firing order</li> <li>6. Engine out of time</li> <li>1. Fouled or damaged propeller</li> </ul>	<p>See Authorized Cobalt dealer. Insure all connections are clean and tight.</p> <p>Correct firing order, see engine manufacturer's owner's manual.</p> <p>See Authorized Cobalt Dealer.</p> <p>Stop engine. Check for weeds on propeller, bent or broken propeller. See your Authorized Cobalt Dealer.</p>
Performance loss	<ul style="list-style-type: none"> <li>1. Throttle not fully open</li> <li>2. Improper fuel</li> <li>3. Overheating</li> <li>4. Boat overloaded</li> <li>5. Boat trim</li> <li>6. Improper propeller selection</li> <li>7. Excessive bilge water</li> <li>8. Boat hull condition</li> </ul>	<p>Check to see that throttle opens fully at carburetor.</p> <p>Fill tank with correct fuel.</p> <p>Check cooling system. Remove weeds from water intake. Check alternator belt tension. Readjust rudder trim tab.</p> <p>Reduce load.</p> <p>Distribute boat load evenly.</p> <p>Select proper propeller pitch and diameter. (See chart in owner's manual).</p> <p>Check for excessive water, drain bilge.</p> <p>Clean if marine growth is present.</p>

## 6. Wiring Diagrams

The diagrams on the following pages outline the electrical system. It is recommended that you let your Cobalt Dealer service any difficulties.

## 7. Circuit Breakers

All electrical standard equipment devices are controlled with circuit breakers. These breakers will activate if overloaded and cut power to the switch. To restore power, simply push the breaker button in and release. (Breakers do not require fuse replacement).

## 8. Lighting/Bulb Replacement

### External Lights

Bow Light Bulb — Perko Fig. 71 12V 10W

Aft Nav. Light Bulb — #90 12V(CS23)

### Internal Lights

Under Dash Panel Courtesy Light — #GE1004MB1

Cuddy Cabin Indirect Lights — #211 12V 12CP

Cuddy Cabin Reading Lights — #1141 12V

Cockpit Courtesy Lights — #211 12V 12CP

### Instrument Lights

Tachometer(s) — #GE161

Speedometer — #GE161

Ammeter(s) — #GE161

Oil Pressure(s) — #GE161

Fuel — #GE161

Trim(s) — #GE161

Temperature(s) — #GE161

Clock — #GE1816

1989

172 Condürre

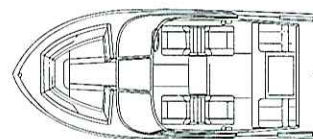

SPECIFICATIONS	
LENGTH	17'2"
WIDTH	8'2"
DECK AREA	141.0
BEAM	8'2"
DRIFT (CR-FLP)	17"
FREEBOARD FWD	34"
FREEBOARD AFT	34"
TRANSOM HEIGHT	41"
AVERAGE WEIGHT	215 LBS
FUEL CAPACITY	31 GAL
POWER SELECTIONS	CYL/OLIN
ENGINE SELECTIONS	CYL/OLIN
ST/200 HP/100	14-353
ST/100 HP/4	14-353
ST/100 HP/4	14-353
ST/100 HP/4	14-353

192 Condürre

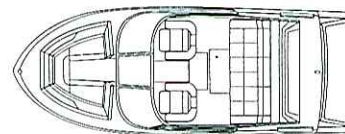

SPECIFICATIONS	
LENGTH	19'2"
WIDTH	11'2"
DECK AREA	214.0
BEAM	11'2"
DRIFT (CR-FLP)	17"
FREEBOARD FWD	34"
FREEBOARD AFT	34"
TRANSOM HEIGHT	41"
AVERAGE WEIGHT	285 LBS
FUEL CAPACITY	31 GAL
POWER SELECTIONS	CYL/OLIN
ENGINE SELECTIONS	CYL/OLIN
ST/200 HP/100	14-353
ST/100 HP/4	14-353
ST/100 HP/4	14-353
ST/100 HP/4	14-353

202 Condürre

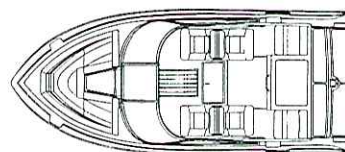

SPECIFICATIONS	
LENGTH	20'2"
WIDTH	12'2"
DECK AREA	244.0
BEAM	12'2"
DRIFT (CR-FLP)	17"
FREEBOARD FWD	34"
FREEBOARD AFT	34"
TRANSOM HEIGHT	38"
AVERAGE WEIGHT	200 LBS
FUEL CAPACITY	42 GAL
POWER SELECTIONS	CYL/OLIN
ENGINE SELECTIONS	CYL/OLIN
ST/200 HP/100	14-353
ST/100 HP/4	14-353
ST/100 HP/4	14-353

203 Condürre

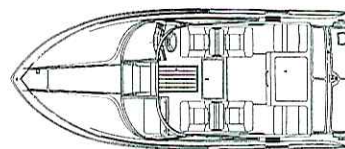

SPECIFICATIONS	
LENGTH	20'3"
WIDTH	12'2"
DECK AREA	244.0
BEAM	12'2"
DRIFT (CR-FLP)	17"
FREEBOARD FWD	34"
FREEBOARD AFT	34"
TRANSOM HEIGHT	38"
AVERAGE WEIGHT	200 LBS
FUEL CAPACITY	42 GAL
POWER SELECTIONS	CYL/OLIN
ENGINE SELECTIONS	CYL/OLIN
ST/200 HP/100	14-353
ST/100 HP/4	14-353
ST/100 HP/4	14-353

222 Condürre

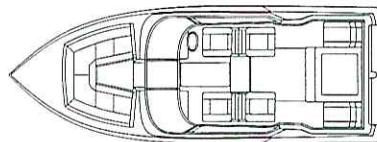

SPECIFICATIONS	
LENGTH	22'2"
WIDTH	13'2"
DECK AREA	294.0
BEAM	13'2"
DRIFT (CR-FLP)	17"
FREEBOARD FWD	34"
FREEBOARD AFT	34"
TRANSOM HEIGHT	41"
AVERAGE WEIGHT	220 LBS
FUEL CAPACITY	50 GAL
POWER SELECTIONS	CYL/OLIN
ENGINE SELECTIONS	CYL/OLIN
ST/200 HP/100	14-353
ST/100 HP/4	14-353
ST/100 HP/4	14-353
ST/100 HP/4	14-353



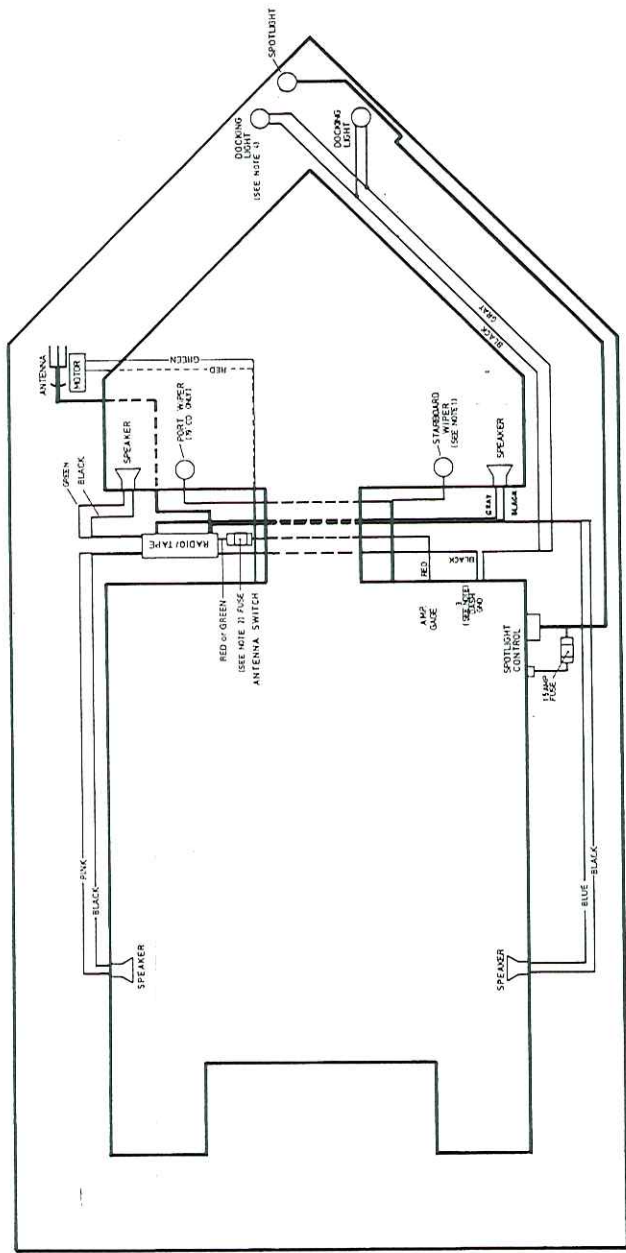

19BR Optional Equipment

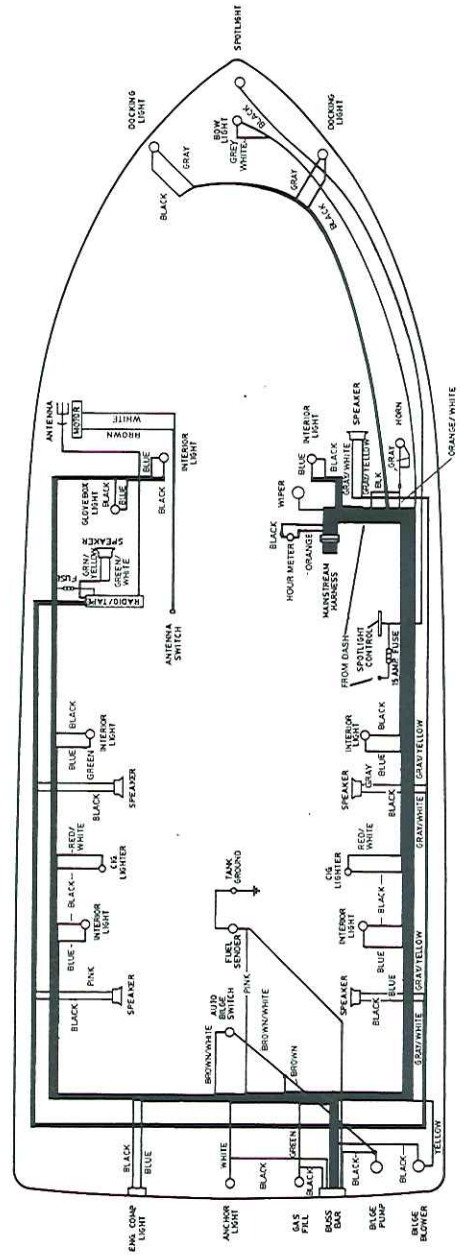

21BR Standard &amp; Optional Equipment





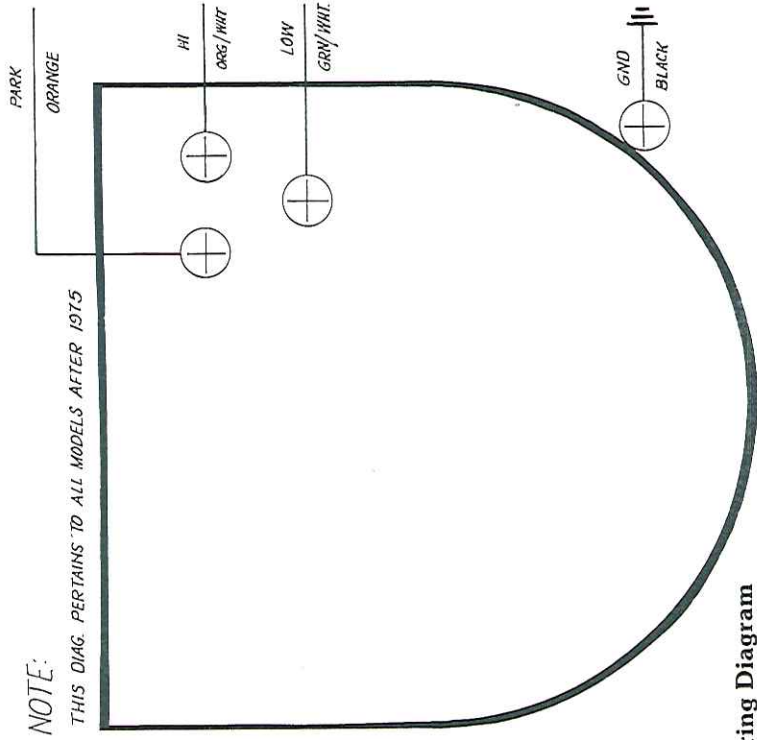

**Wiper Motor Wiring Diagram**

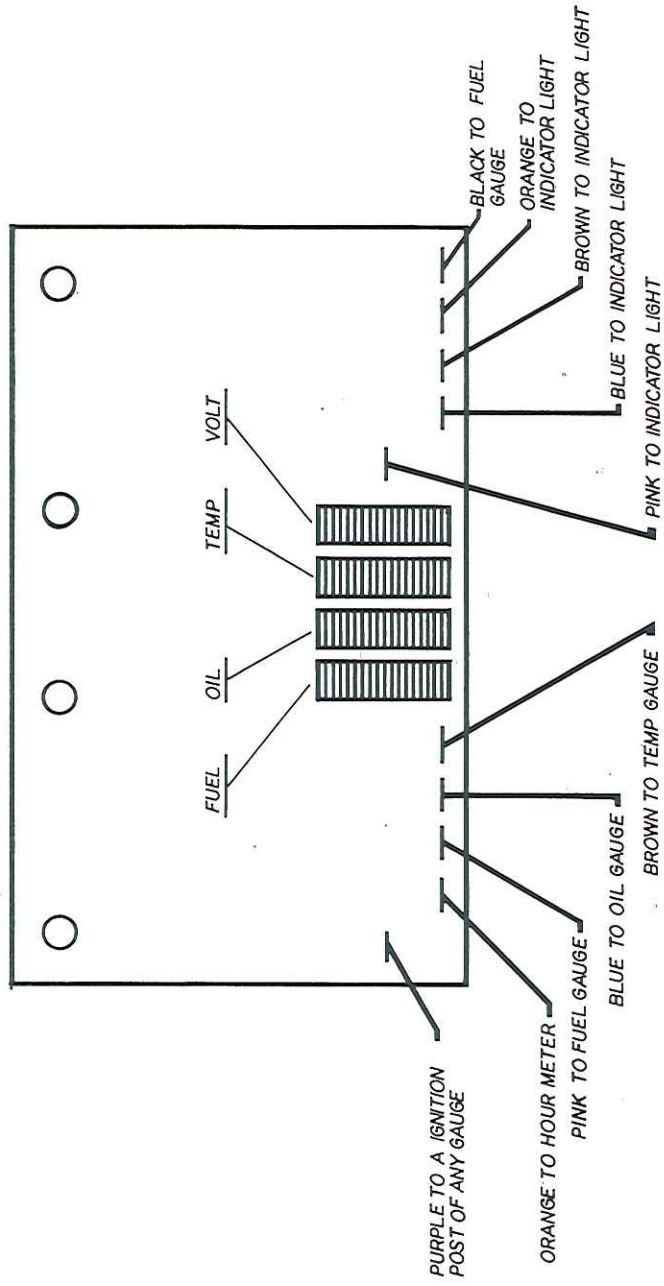

**Printed Circuit Board**

## THE COBALT WARRANTY

### **FIVE YEAR LIMITED TRANSFERABLE WARRANTY ON HULL AND DECK, TWO YEAR LIMITED TRANSFERABLE WARRANTY ON OTHER COMPONENT PARTS**

Cobalt Boats warrants the hull and deck of each new Cobalt boat to be free from structural defects in material and workmanship under normal recommended use for a period of five (5) years from the date of delivery to the original retail purchaser.

Cobalt Boats warrants all component parts, other than the hull and deck, of each new Cobalt boat to be free from structural defects in material and workmanship under normal recommended use for a period of two (2) years from the date of delivery to the original retail purchaser.

This warranty does not apply to (1) engines, boat drives, controls, batteries, or other equipment or accessories manufactured by manufacturers other than Cobalt Boats, which are separately warranted by such other manufacturers (appropriate adjustments therefor being provided by their respective manufacturers); (2) installation of engines or accessories installed by others; (3) windshield leakage, upholstery damage, carpet damage and gelcoat damage; (4) the blistering of gelcoat finishes; and (5) any Cobalt boat which has been altered, subjected to misuse, negligence or accident, or used for racing or commercial purposes.

The rights and benefits granted under this warranty to the original retail purchaser of a new Cobalt boat shall extend to any owner of such Cobalt boat during the applicable warranty period, commencing with the date of delivery to the original retail purchaser, as set forth herein, provided this warranty is validated by such owner, as set forth herein. In no event shall the owner of any Cobalt boat, covered by this warranty, have any rights or benefits under this warranty which are greater than the rights and benefits which would have been available under this warranty to the original retail purchaser of such Cobalt boat had the original retail purchaser remained the owner of such Cobalt boat.

Cobalt Boats shall not be liable for special or consequential damages, such as, but not limited to, damages for cost of

replacement goods, or damages for claims of third parties against the purchaser, or damages for loss of profits.

To validate this warranty, the original retail purchaser must return the warranty registration card to Cobalt Boats within ten (10) days after purchase of any new Cobalt boat covered by this warranty, and any subsequent owner of a Cobalt boat during the applicable warranty period must give written notice of acquisition of a Cobalt boat to Cobalt Boats within ten (10) days after such purchase.

Notification of any warranty claim, arising within the applicable warranty period, as set forth above, must be made in writing by the owner of the Cobalt boat or by an authorized Cobalt Boats dealer to Cobalt Boats within thirty (30) days after the discovery of the alleged basis for any warranty claim.

During the applicable warranty period, as set forth above, warranty repairs shall be made without charge by Cobalt Boats at its plant in Neodesha, Kansas, or, at the option of Cobalt Boats, by an authorized Cobalt Boats dealer. All warranty repairs shall be subject to the authorization of factory-trained personnel of Cobalt Boats, whose decision will be final. Transportation to and from the Cobalt Boats plant in Neodesha, Kansas, and/or to and from an authorized Cobalt Boats dealer, for warranty repairs, shall be at the owner's expense.

In no event shall the liability of Cobalt Boats under this warranty exceed the purchase price of the specific item or items to which such warranty relates.

This warranty constitutes the only express warranty covering a new Cobalt boat. Any implied warranty, which may be determined to pertain to any component of a new Cobalt boat, is limited to five (5) years on the hull and deck, and limited to two (2) years on all other component parts covered by the express warranty, as set forth above, except in those states which have other limitations on the duration of an implied warranty.

This warranty gives you specific rights and remedies. In addition, you may also have other rights and remedies which vary from state to state.

