

# 1993



## COBALT BOATS

OWNERS MANUAL

---

---

# 1993 COBALT

---

*Your concern for proper operation, care and maintenance will provide you with many years of boating satisfaction.*

*This manual has been prepared to acquaint you with the operation and maintenance of your Cobalt. We suggest you read this manual carefully and follow the recommendations to assure enjoyable and trouble-free operation.*

*As you read this manual, remember that "common sense" and "courtesy" are the most valuable traits you can have to fully enjoy safe boating.*

*It is also to your own personal advantage to become well acquainted with the rules and general "know how" of boating.*

*For service and assistance, remember to call on your Cobalt dealer. He will be happy to assist you in matters concerning maintenance, warranty and any other questions you may have concerning your Cobalt.*

# **LOCATION GUIDE**

- |  |             |
|--|-------------|
| <b><i>I. Equipment and<br/>Government Regulations</i></b>          | <b>I</b>    |
| <b><i>II. Boating Industry<br/>Associations Certification</i></b>  | <b>II</b>   |
| <b><i>III. Interior/Exterior Care</i></b>                          | <b>III</b>  |
| <b><i>IV. Boat Operation</i></b>                                   | <b>IV</b>   |
| <b><i>V. Propellers and<br/>Propeller Chart</i></b>                | <b>V</b>    |
| <b><i>VI. Technical Information</i></b>                            | <b>VI</b>   |
| <b><i>VII. Warranty Procedure and<br/>Owner Responsibility</i></b> | <b>VII</b>  |
| <b><i>VIII. Service Record Pages</i></b>                           | <b>VIII</b> |

**I. Equipment and Government Regulations**

1. Lights ..... 3

2. Whistle or Horn ..... 3

3. Fire Extinguisher ..... 3

4. Life Saving Devices ..... 3

5. Additional Recommended Equipment ..... 4

6. Inland Lakes ..... 4

7. Intracoastal Waters ..... 4

## I. EQUIPMENT AND GOVERNMENT REGULATIONS

### 1. Lights

Motorboats **underway** between sunset and sunrise must display proper lights. A boat at **anchor** must display a white anchor light less than 20 feet over the hull and must be visible for at least one mile to a boat approaching from any direction.

The lighting on your Cobalt complies with B.I.A., U.S. Coast Guard and A.B.Y.C. standards.

**NOTE: Consult your local and regional navigational authority for any additional lighting requirements.**

### 2. Whistle or Horn

All boats over 16 feet in length are required to have an operational horn or whistle which is audible at least one mile. Your Cobalt is so equipped.

**NOTE: Check your horn periodically for proper operation.**

### 3. Fire Extinguisher

All I/O boats are required to carry appropriate portable fire extinguishers. Your Cobalt is "standard equipped" to meet the fire extinguisher regulations.

**NOTE: Check your fire extinguisher gauge frequently to determine proper charge.**

### 4. Life Saving Devices

All boats must carry one Coast Guard approved type 1, 2, or 3, (wearable) device for every person on board. In addition, each boat over 16 feet in length is required to carry one approved type 4 throwable life saving device such as a ring life buoy or buoyant cushion. When the approval stamps are no longer legible and the equipment cannot otherwise be identified as being approved, the equipment must be replaced with currently approved equipment.

## 5. Additional Recommended Equipment

Cobalt Boats wants your recreation time to be enjoyable and without incident. We suggest the following items be aboard in the event of an accident or problem situation:

1. Compass
2. Distress signal flares
3. Flashlight
4. First Aid Kit
5. Anchor and anchor line
6. Tool Kit
7. Paddle

**NOTE: It is recommended that you consult with your dealer for the appropriate types of safety devices for the area in which you boat.**

## 6. Inland Lakes

All boats operating on inland lakes are under the jurisdiction of state governments. You should check with your dealer for the source of the rules and regulations that will affect you on your local inland waterway.

## 7. Intracoastal Waters

Regulations governing equipment necessary while operating in intracoastal waters are different than inland rules. Make sure you have the proper equipment on board. The best source for information regarding rules and regulations for intracoastal waters is the U.S. Coast Guard.

**NOTE: The U.S. Coast Guard has all the information you will require for safe and legal operation of your boat in intracoastal waters. They also provide numerous informational pieces regarding general practices for safe and enjoyable boating. Your dealer will advise you on how to contact the U.S. Coast Guard or you may wish to call 202/267-0973.**

**II. Boating Industry Associations Certification 6**

**II**

## II. BOATING INDUSTRY ASSOCIATIONS CERTIFICATION

Boating Industry Associations is a National Trade Association serving all elements of the Recreational Boating Industry.

Its members include manufacturers of all types of boating equipment - outboard and inboard boats, sailboats, marine engines, outboard motors, boat trailers, boating accessories and supplies.

B.I.A. certification means that you, a new Cobalt owner, can rest assured that lighting, ventilation, steering, flotation, capacity, fuel system, horsepower rating and anything that will insure your safety are within the rigid U.S. Coast Guard requirements. Your Cobalt is B.I.A. Certified, and meets U.S. Coast Guard and A.B.Y.C. standards.

### **III. Interior/Exterior Care**

1. Vinyl Interior/Upholstery Care/Leather Care 8
2. Vacuuming ..... 11
3. Carpet Care ..... 11
4. Teakwood Care ..... 11
5. Canvas/Top/Camper Care ..... 12

### III. INTERIOR/EXTERIOR CARE

#### 1. Vinyl Interior/Upholstery Care/Leather Care

The vinyl fabric in your Cobalt's interior has been especially selected to take the tough punishment of the elements and hard usage of an active boater. With all its toughness and wear qualities, it is no match for a screwdriver you forgot to take out of your pocket before sitting down — avoid sharp objects coming in contact with vinyl.

As you probably know, the vinyl in your Cobalt is treated with PreFixx. However, this does **not** mean that it cannot be stained. There are three families of sunscreen ingredients which may contribute to the staining of the vinyls in your Cobalt.

- Aminobenzoic acids — e.g. PABA
- Hydroxy benzophenones — e.g. Oxybenzone
- P-methoxycinnamic acid — e.g. Octyl methoxycinnamate

This list should **not** be considered inclusive, although it does represent a large selection of sunscreens which are known to stain vinyls, even treated with PreFixx. In actuality, almost any sunscreen with a high percentage — two percent or above — of active ingredients are potential stainers.

Special care should be taken **not** to allow dark color rubber products to come in contact with the vinyl upholstery. The optional travel/mooring cover comes with black rubber straps and these straps could stain the vinyl permanently.

#### Care and cleaning — vinyl & fabrics

**Day-to-day soil.** Remove ordinary dirt and smudges with a mild soap and warm water solution. Dry with a soft, lint-free cloth or towel. For more difficult stains, use of a stronger detergent is recommended provided the detergent manufacturer's instructions are followed closely.

**Special cleaning problems.** The following steps are recommended to clean stains on PreFixx-protected vinyl upholstery. Many difficult stains can be removed when these cleaning agents are used in the following order.<sup>1</sup>

**Step 1 cleaners:** Nonabrasive household cleaners to be used with a cloth, damp sponge or fine bristle brush.

- All-Purpose Spray Cleaner.

- Clorox™, Soft Scrub® with bleach.
- Household cleaners and bleaches. Rinse cleaned area with fresh water and dry with a clean cloth.

**Step 2 cleaners:**\* Solvent-type cleaner to be liberally applied with a cloth, damp sponge or fine bristle brush.

- Rubbing alcohol (isopropyl alcohol).
- Lighter fluid (naphtha). Rinse cleaned area with fresh water and dry with a clean cloth.

**Step 3 cleaners:**\* Strong, active cleaners to be applied with a soft cloth or damp sponge. Use no more than six rubs; if stain persists, contact manufacturer. Dry with another cloth, then rinse with clear water and dry.

- Nail polish remover (acetone/water).

<sup>1</sup> Note: It is extremely important to clean the stained area as quickly as possible, making sure the recommended cleaning steps are followed in order.

**\*CAUTION: THESE SOLVENTS ARE HIGHLY FLAMMABLE. EXERCISE PROPER CARE IN CLEANING AND NOTIFY PERSONNEL IN AREA OF DANGER. WEAR RUBBER GLOVES DURING ALL CLEANING ACTIVITY. USE CAUTION IN CLEANING AROUND STITCHING AND WOODEN OR OTHER DECORATIVE TRIM, SINCE THESE SOLVENTS COULD SERIOUSLY DAMAGE SUCH AREAS.**

**DANGER: FLAMMABLE LIQUIDS ARE EXTREMELY DANGEROUS AND SHOULD BE USED ONLY WITH THE GREATEST OF PRECAUTIONARY MEASURES. DO NOT USE A FLAMMABLE LIQUID IN YOUR BOAT WHEN ANOTHER CLEANER CAN BE USED.**

### Recommended cleaning solutions for PreFixx-coated Nautolex.

Staining Agent	Cleaning Steps
Spray paint	1-2-3
Ballpoint pen	1-2-3
Lipstick	1-2-3
Yellow mustard	1-2-3
Bird droppings	1-2-3
Suntan lotion	1-2-3
Crayons	1-2
Eye shadow	1-2
Oily soot	1-2
Petroleum products	1-2
Coffee	1
Tea	1
Hair oil tonic	1
Blood	1
Urine	1
Grape juice	1
Olive oil	1
Chocolate	1
Ketchup	1
Baby oil	1

© 1988 GenCorp Polymer Products Printed in U.S.A.  
Nautolex® and PreFixx™ are trademarks of GenCorp Polymer Products.

Often, when a boat is stored completely covered or in a dark building, the vinyl will darken or become “dingy” looking. If this happens, simply place the boat in direct sunlight for a few hours and the vinyl will brighten up.

### Taking care of leather

#### For Spots and Spills.

Wipe excess liquid up *immediately* with a clean absorbent cloth or sponge. If necessary, use clean luke warm water only and let air dry naturally. If water is used, clean the entire area where the spot occurred. An example would be the entire seat cushion or entire arm. Do not dry wet areas with hair dryers, etc.

#### For Stubborn Spots and Stains.

Use a mild non-detergent cleaner such as a bar of Ivory soap or Amway L.O.C. Apply the soap to a clean wet sponge and wash, then rinse well. Let air dry naturally.

### **For Butter, Oil or Grease.**

Wipe excess butter, oil or grease off the leather with a clean dry cloth, then leave it alone as the spot should dissipate into the leather in a short period of time. Do not apply water or try to wash a butter, oil or grease spot.

### **Do Not Use.**

Saddle Soap, cleaning solvents, furniture polish, oils, varnish, abrasive cleaners, soaps or ammonia water.

**NOTE: 1) These are recommended or suggested methods of cleaning, but the manufacturer is not responsible for damage incurred while cleaning.**

**2) Always try the cleaning method in a hidden area first to convince yourself of the results.**

## **2. Vacuuming**

A very effective and easy way to keep your interior ship shape is giving it a good vacuuming. You may use your own canister type or the ones available at a car wash. The vacuum cleaner allows you to pick up in tight areas such as under bow, jump and lounge seats. It's also a great way to clean up any debris in the bilge area. (If you're at a car wash, it's a good idea to use the pressure nozzle to wash the bilge area prior to vacuuming, using care not to direct spray on engine, carburetor, distributor, alternator or starter.)

## **3. Carpet Care**

The carpet in your Cobalt is made of the finest materials available. Scrubbing with soapy water will handle most tough jobs. A simple hosing for mild cleanups will bring out that new look again. Your dealer can suggest methods of cleaning difficult stains in your carpet.

**DANGER: FLAMMABLE LIQUIDS ARE EXTREMELY DANGEROUS AND SHOULD BE USED ONLY WITH THE GREATEST OF PRECAUTIONARY MEASURES. DO NOT USE A FLAMMABLE LIQUID IN YOUR BOAT WHEN ANOTHER CLEANER CAN BE USED.**

#### 4. Teakwood Care

If the care of teakwood is completely ignored, you can expect its color to turn gray. In addition to the fading of its color, the surface finish will tend to become rough. This roughing results and gradually becomes more apparent as the oil in the wood evaporates or dries out causing a shrinking and separation of the wood's grain.

For appearance sake and to avoid this "roughing" it is suggested that you use an application of Cobalt teak oil. Instructions for use are on the label.

#### 5. Canvas/Top/Camper Care

Boat canvas, in most cases, is subjected to more severe punishment than any other type of canvas or fabric item.

Moisture, dirt, heat, ultraviolet rays, salt water, and chemicals from industrial fallout are all factors anxious to destroy your boat canvas. These elements can do serious damage if left unchecked. Following are some ways to slow the destructive process of canvas:

**MOISTURE** — Can cause shrinkage, mold, and mildew. The best method of prevention is to allow all canvas items to dry thoroughly while installed on the boat. Shrinkage can occur anytime an article is allowed to dry while loose. Most shrinkage will occur the first few months after initial installation. When canvas items are erected on the boat and properly adjusted, shrinkage can only occur in areas of looseness. Mold and mildew can be avoided by keeping your unit clean and well ventilated.

**DIRT** — Can create a starting point for mold when moisture is present. Cleaning periodically with a mild detergent and water while unit is erected on the boat will extend the canvas life and provide a better appearance. Cleaning can be accomplished with a sponge, soft scrub brush or by using one of the serve-yourself car washes. The unit should always be erected fully and adjusted to a tight, smooth appearance before washing. Allow unit to air dry thoroughly before removing curtains.

**CHEMICALS** — From industrial fallout can cause decay of vinyls and fabrics if allowed to accumulate. There are many different types of chemicals involved. Keeping your unit clean and covered is the best answer to prevent decay from chemical fall-

out. Many types of covers are available, check with your dealer for an appropriate cover for your use.

**HEAT** — Any vinyl coated fabric when enclosed in a polyethylene container and subjected to sunlight is subjected to potential cracks in the vinyl component and a stiffening effect on the fabric. Polyethylene bags or tubes are meant only for protection during shipping and handling.

**NOTE: Do not use polyethylene bags or tubes for stowage of canvas.**

**ULTRAVIOLET DEGRADATION** — Most synthetic fabrics or nylon parts today are U.V.R. treated to resist ultraviolet effects. The best protection, however, is to avoid long periods of stowage in areas subject to direct sunlight.

**SALT WATER** — Corrosive effects of salt water, as well as chemicals from industrial fallout, can corrode brass or aluminum fittings or fasteners. Your canvas has snap fasteners made of stainless steel. These can be protected by keeping them clean and occasionally lubricating them with petroleum jelly.

In summary, the things you can do to protect your canvas items for extended years of enjoyment are:

1. Keep it clean. **DO NOT** use harsh cleaners.
2. Side curtains and rear window demand extra care to prevent scratching. Ideally, they should be washed with clear water, preferably hosed off, wiping them with your hand at the same time. Do not attempt to use a cloth or chamois skin. Any dirt or grit in the cloth may result in scratches. Clear water and using your (clean) hand is the safest way. When storing canvas with windows or side curtains, they should be rolled rather than folded to prevent kinking and cracking.
3. Be sure that the top is completely dry before stowing.
4. Keep unit well ventilated when stowed. **NO POLY BAGS.**
5. Keep fasteners clean and lubricated.

The materials used to produce your boat top and curtains are the best obtainable. Reasonable care will assure them of a long life and many years of service.

**NOTE: For storage, we recommend an optional travel/mooring cover of duck canvas that has the ability to breathe. Do not use convertible tops, side curtains, aft curtains, tonneau covers, etc. for long term storage. These tops were not designed for long term storage. Adequate ventilation is not possible and mold/mildew will form. For more information on appropriate covering for long term storage, please see your Cobalt Dealer.**



#### **IV. Boat Operation**

1. Erecting Canvas Top . . . . .	16
2. Stowage of the Canvas Top . . . . .	23
3. Canvas Maintenance . . . . .	23
4. Seat Adjustment and Operation . . . . .	24
5. Cuddy Cabin Access Doors . . . . .	26
6. Instrument Panel . . . . .	27
7. Engine Control . . . . .	29
8. Steering System . . . . .	33
9. Power Trim . . . . .	34
10. Warning Labels . . . . .	34
11. High Speed Operation . . . . .	36
12. Lifting Your Cobalt . . . . .	36
13. Trash Receptacle . . . . .	38
14. Fold Down Boarding Ladder . . . . .	38
15. Water Ski Towing . . . . .	38
16. Deck Hatch . . . . .	39
17. Engine Accessibility . . . . .	39
18. Fuel Filling . . . . .	40
19. Ignition Safety Switch . . . . .	40
20. 272 Condurre . . . . .	41
21. Optional Equipment . . . . .	42

## IV. BOAT OPERATION

### 1. Erecting Canvas Top (See Figure 1)

#### a. Convertible Top — (standard)

1. Remove canvas top, bow, and extension legs from “top storage area”.
2. Attach extension legs to top mounts on each side of the boat. (Use quick disconnect pins or knurled knobs.)
3. Slide top bow onto extension legs with the short bow closest to the windshield. (Note: some models do not use extension legs.)
4. Remove storage boot and unroll canvas top.
5. Open frame and snap front of canvas to windshield.
6. Snap the tail panels or straps to the sides of the boat.

#### b. Side Curtains — optional (See Figure 2)

1. Zip the side curtains to the top.
2. Snap curtains to windshield and deck.

#### c. Stern Curtain — optional (See Figure 2)

1. Zip the stern curtain to the canvas top, snap the curtain to the deck, starting at the center rear of the curtain and working forward evenly.

#### d. Camper Top — optional (See Figure 3)

1. Install “Convertible Top” as outlined in (a).
2. Remove “Camper Top” extension legs from storage area.
3. Attach extension legs to “Camper Top” mounts (toward rear of boat) on each side of the boat.
4. Slide “Camper Top” bow into extension legs with the short bow toward the bow of the boat.
5. Remove storage boot and unroll “Camper Top” canvas.
6. Open “Camper Top” frame and zip front of “Camper Top” canvas to rear of “Convertible Top”.
7. Zip side curtains to “Convertible Top”.

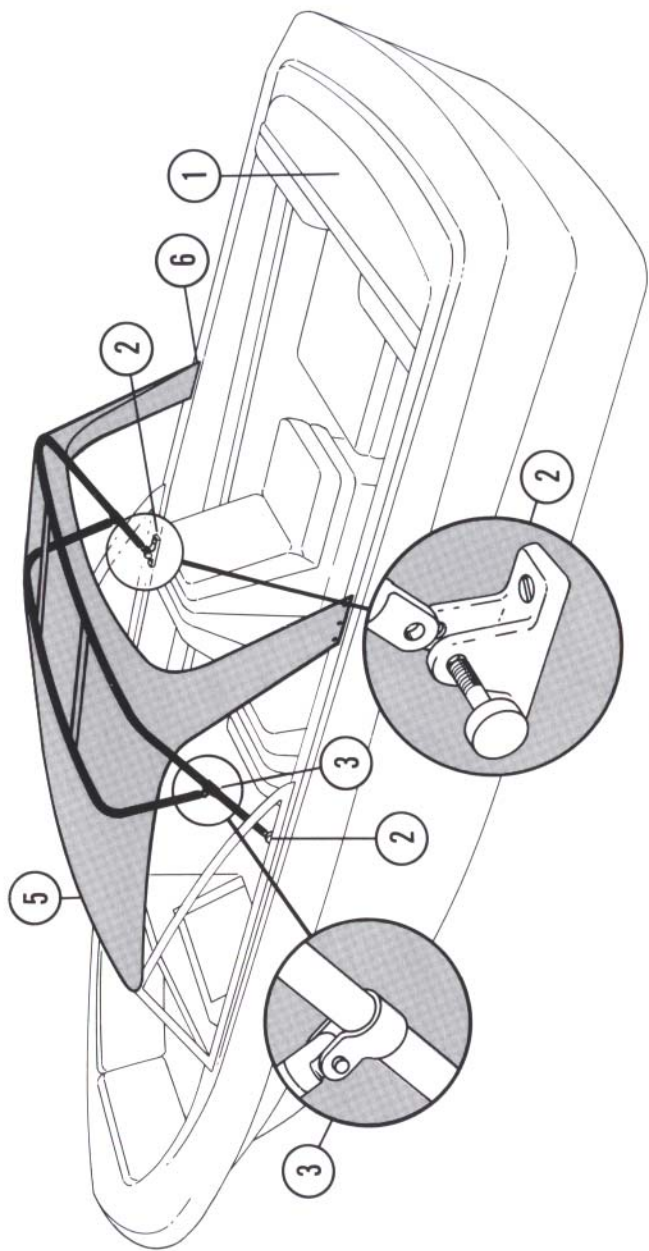

Convertible Top  
Figure #1

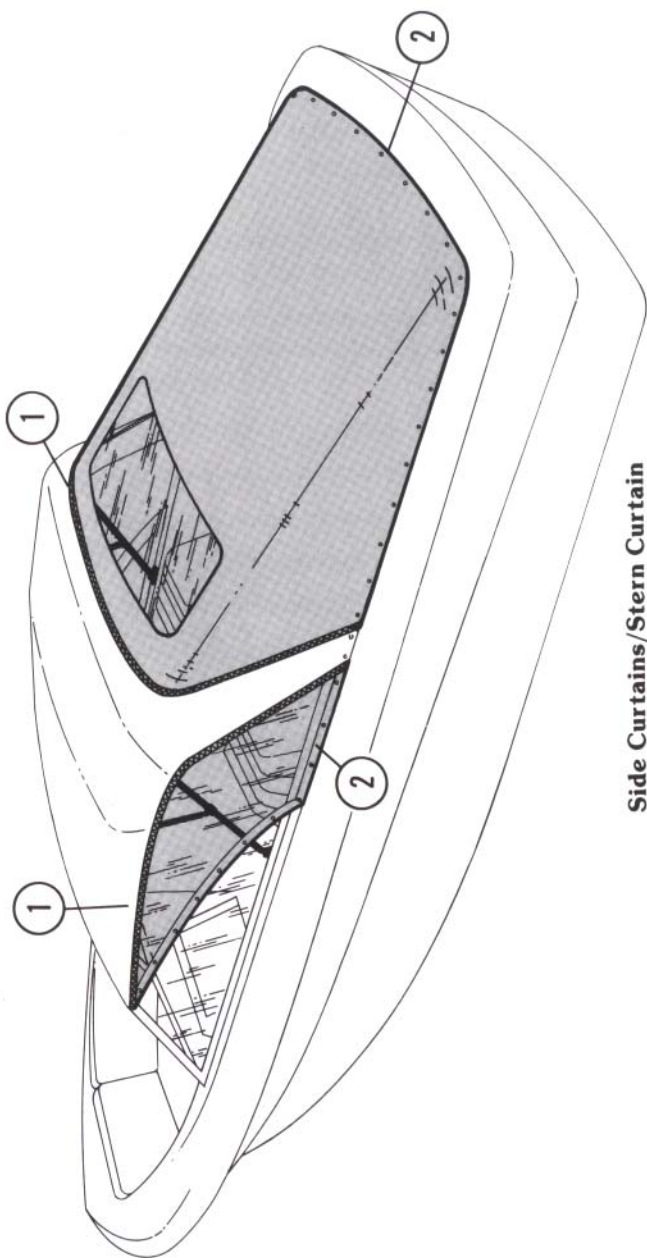

Side Curtains/Stern Curtain  
Figure #2

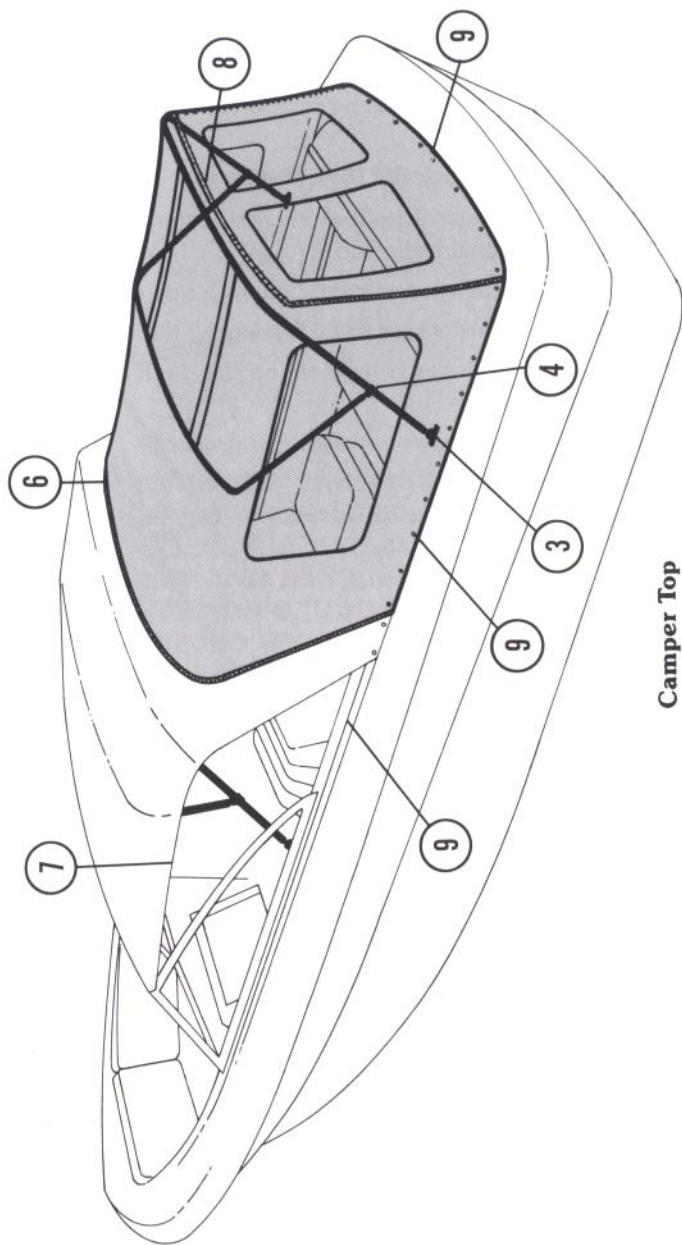

Camper Top  
Figure #3

8. Zip aft curtain to “Camper Top”, starting at the center rear of the curtain and working forward evenly.
9. Snap side, aft curtains and camper top to deck, working forward evenly.

**e. Bimini Top — optional (See Figure 4)**

1. Due to the length of the bows, there is no storage provided for the optional bimini top.
2. Attach top bow to top mount on each side of the boat.
3. Attach forward straps to the eyelets on the windshield.
4. Attach aft straps to eyelets on the deck aft of the windshield.
5. Adjust the straps as necessary for proper fit.

**WARNING: THE OPTIONAL “BIMINI TOP” IS FOR LOW SPEED OPERATION ONLY, (LESS THAN 15 MPH AIR SPEED). IF IT IS USED IN HIGHER AIR SPEED THAN 15 MPH, IT COULD COME LOOSE OR COMPLETELY OFF, CAUSING INJURY TO THE OCCUPANTS OF THE BOAT.**

**f. Bowrider Tonneau Cover - optional (See Figure 5).**

1. Open walk-thru doors.
2. Starting at bow and working aft, snap cover to boat.
3. Close windshield center door and snap the canvas to the underside of the door.
4. Install the adjustable tonneau cover pole thru the grommet and adjust to “tent” the cover.
5. Walk-thru doors may be closed if desired.

**NOTE: For storage, we recommend an optional travel/mooring cover of duck canvas that has the ability to breath. Do not use convertible tops, side curtains, aft curtains, tonneau covers, etc. for long term storage. These tops were not designed for long term storage. Adequate ventilation is not possible and mold/mildew will form. For more information on appropriate covering for long term storage, please see your Cobalt Dealer.**

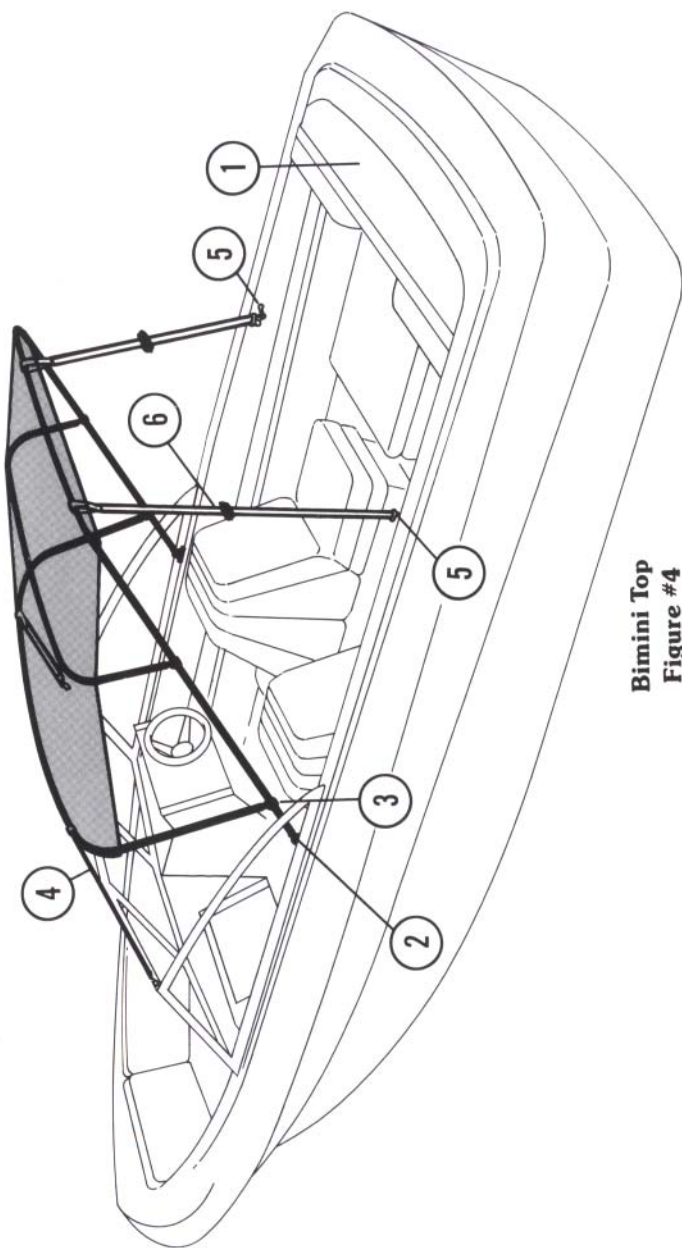

**Bimini Top  
Figure #4**

**IV**

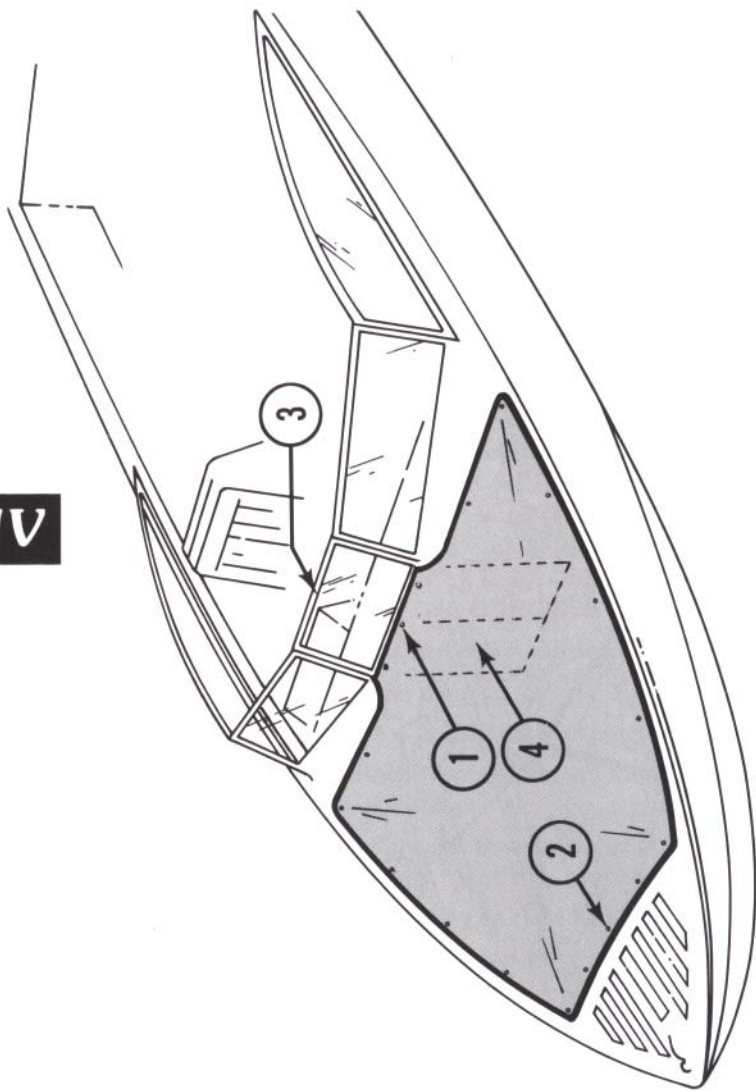

**Bowrider Tonneau Cover  
Figure #5**

**DANGER: DO NOT OPERATE YOUR COBALT WITH THE STERN CURTAIN OR CAMPER TOP CANVAS COMPLETELY CLOSED. THE COCKPIT MUST BE OPEN FOR FUEL COMPARTMENT VENTILATION.**

## **2. Stowage of the Canvas Top**

The following is the recommended procedure for folding and storage of the top:

- a. Disconnect the tail panels from the side of the boat and allow them to hang free.
- b. Disconnect the top snaps from the windshield. (At this point, the two bows should still be separated.)
- c. Grasp the bows and fold them together. (Allow the canvas to gather between the bows.)
- d. Roll the canvas around the bows. (As you roll the canvas, assure its tightness and pull the side of the canvas to prevent wrinkling.)
- e. Slide the boot over the canvas and snap or zip.
- f. Remove the top from the “top bow extension legs” and stow the top in the “top storage compartment”.
- g. Remove the extension legs and stow them in the “top storage compartment”.

**NOTE: Make sure all canvas is completely dry before storage to prevent mildew.**

## **3. Canvas Maintenance**

The fabric is first soaked (with occasional agitation) in a solution with the following proportions of Clorox and Ivory Flakes.

- 1/2 cup (4 oz.) Clorox
- 1/2 cup (4 oz.) Ivory
- 1 gallon lukewarm water

Let the fabric remain soaking in this solution until most of the stains disappear or for 20 minutes.

The fabric may be washed in an automatic washer on the COLD cycle using 2 cups (16 oz.) Clorox and one cup (8 oz.) Ivory Flakes. Line dry the canvas.

**NOTE: UNDER NO CIRCUMSTANCE are these fabrics to be put in HOT WATER. UNDER NO CIRCUMSTANCE are these fabrics to be run through the HOT drying cycle of an automatic dryer. FABRIC SHOULD BE LINE DRIED. UNDER NO CIRCUMSTANCE ARE THESE FABRICS TO BE STEAM PRESSED AT A DRY CLEANER.**

If leaking occurs after washing this may be the result of insufficient rinsing. If the fabric continues to leak after a very thorough rinsing, it may be necessary to apply a coat of silicone air drying water repellent. This should be done on a warm, sunny day, giving the application sufficient time to completely dry. Such silicone water repellents are available through Scotchgard or 3-M Company products.

#### **4. Seat Adjustment and Operation**

##### **a. Sleeper Seats**

**(See Figure 6)**

The driver's seat is adjustable fore and aft. To attain desired position, lift the release handle (mounted under the forward lip of the driver's seat cushion), move seat, and release handle. Make sure handle retracts fully and seat is locked in place.

The passenger's seat is not adjustable in most models.

To adjust the sleeper seat in the reclining position, grasp the forward edge of the seat cushion and lift until the mechanism releases. Extend the seat into the reclining position. On the driver's side, it will also be necessary to lift the release handle to slide the front of the mechanism to its most forward position. Reverse this procedure to replace in sitting position.

**(See Figure 6)**

While in the reclining position, the after-most cushion can be raised and locked into a lounge position. To lock, press the support legs to an over center position. These are located under the cushion and are exposed when the cushion is raised. Reverse this procedure to return to normal position.

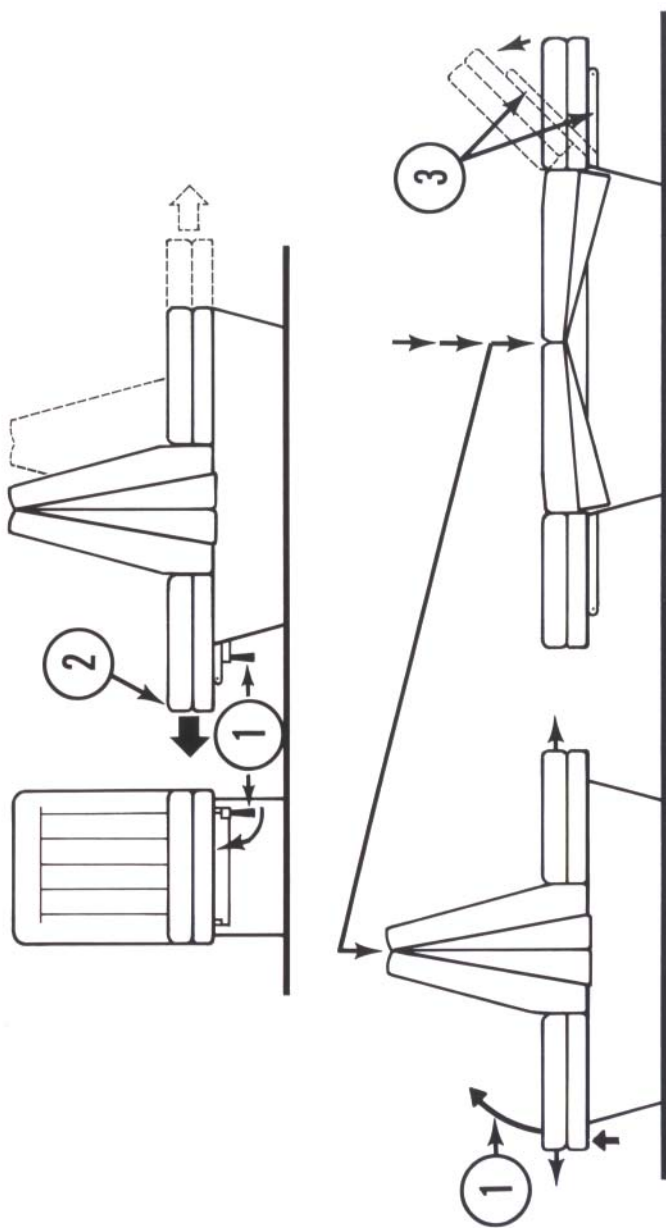

Sleeper Seat  
Figure #6

### b. Captains Chairs (Pedestal Mount)

The captain's chairs are adjustable fore and aft and also rotate. There are two large handles under the seat. Turning counter-clockwise loosens the slide mechanism and swivel and clockwise tightens them. Loosen either or both, place the chair in the desired position and tighten securely to hold in place.

Your captain's chair(s) has the flip-up position for greater visibility and maneuverability while docking. You can sit on the raised cushion or stand in front of the cushion. We recommend the driver and passengers remain seated at any speeds greater than idle.

**WARNING: DRIVING WHILE STANDING UP IS AN EXTREMELY HAZARDOUS PRACTICE. DO NOT DRIVE WHILE STANDING AT SPEEDS GREATER THAN "IDLE SPEED".**

### c. Rear Bench Seat Assembly

#### 1. Engine Access

The entire bench seat assembly lifts for engine access.

#### 2. Sleeper Position (22T, 243, 255)

Release the slide bolts on the front of the seat cushion. This will allow the cushion to slide forward forming a berthing area.

**CAUTION: THE SEAT SHOULD BE IN THE UPRIGHT AND LOCKED POSITION WHEN THE ENGINE IS RUNNING.**

## 5. Cuddy Cabin Access Doors

### a. 223/243/255 Condurre Sliding Door

The sliding door assembly can be in the open or closed position while running. To release the latch mechanism, simply lift the knob or handle and while holding in the raised position, slide the door to the desired position and release latch. To lock door (open or closed) use key lock which locks latch mechanism in place.

**WARNING: THE COMPANIONWAY HATCH MUST BE CLOSED WHILE THE BOAT IS UNDERWAY. LEAVING THE COMPAN-**

**IONWAY HATCH OPEN WHILE UNDERWAY CAN OBSTRUCT THE DRIVER'S VISION CREATING A DANGEROUS SITUATION.**

**6. Instrument Panel (please refer to pages 31-32)**

1. Fuel Gauge — shows approximate amount of fuel remaining in tank.
2. Voltmeter/Dynamo — shows the condition of charge in the battery. It only indicates while the ignition is in the “ON” position. With the engine at idle or not running, it may show as low as 10 to 12 volts. With the engine running at cruising speeds and above, it should show 12 to 14 volts.
3. Speedometer (Miles Per Hour)
4. Rudder Indicator — shows position of drive unit in relation to the center line of the boat.
5. Tachometer — (Revolutions Per Minute)
6. Oil Pressure Gauge

Pressure can vary according to type of engine. It is normal for a hot engine to have low pressure at idle, (depending on type of oil, pressure may drop as low as 10 PSI at idle).

Please consult the engine owners manual supplied with your boat concerning the oil pressure the engine in your boat should attain.

7. Temperature Gauge

Temperature may fluctuate slightly while running. Maximum temperature may vary depending on type of engine.

**WARNING: SHOULD WATER TEMPERATURE REACH 180 DEGREES FAHRENHEIT, YOUR ENGINE IS OVERHEATING AND SHOULD BE CHECKED IMMEDIATELY FOR PROBABLE CAUSE.**

8. Trim Gauge — Shows the position of the drive unit in reference to the bottom of the boat.
9. Horn Button — The horn, itself, is located under the deck on starboard side.
10. Lighter.
11. Bilge Blower Indicator — Red light indicates when bilge blower is operating.

12. Bilge Pump Indicator — Red light indicates when bilge pump is operating.
13. Interior Light Indicator — Red light indicates when interior lights are on.
14. Dash Light Indicator — Red light indicates when dash instrument lights are on.
15. Exterior Light Indicator — Red light indicates when navigation or anchor light is on.
16. Two Position Switch — Controls equipment as labeled.
17. Three Position Exterior Light Switch
  - Up position — navigation (running) lights, bow light and stern light.
  - Center position — off.
  - Down position — stern light only.

**WARNING: NEVER OPERATE YOUR BOAT AT NIGHT WITHOUT ALL OF THE REQUIRED LIGHTS OPERATING. (THIS INCLUDES BOW LIGHT AND STERN LIGHT.)**

18. Circuit Breakers
  - Push to reset if necessary. If the button continues to pop out, consult your Authorized Cobalt Dealer.
19. Ignition Key Switch
20. Indicator Light — For auxiliary equipment.
  - NOTE: Items 21 thru 24 apply to 22T only.**
21. Low Fuel Indicator — Will momentarily light when ignition is first turned on. It will indicate with approximately  $\frac{1}{8}$  tank or less of fuel.
22. High Temperature Indicator — Will momentarily light when ignition is first turned on. It will indicate when engine temperature exceeds approximately 170 degrees.
23. Low Oil Pressure Indicator — Will momentarily light when ignition is first turned on, then go off. If the engine is not started, and the ignition key is left on, it will indicate after approximately 30 to 60 seconds (warm up). It will immediately indicate when oil pressure drops below 5 - 7 lbs.

**NOTE: Many Chevrolet V-8 engines will idle when hot with pressure in the 5-7 pound range**

**which will make the indicator light flicker slightly. This is normal. If the light indicates steadily, have your dealer check the system before further use.**

**NOTE: Items 21 - 23 are dealer adjustable to suit your individual needs.**

24. Low Voltage — Will momentarily light when ignition is first turned on. It will indicate if the electrical system drops below 10.8 volts. If the engine is not running with the ignition on, or at a dead idle, and you have many electrical items turned on such as lights, blower, pump, etc., the light may indicate. If the engine is accelerated above approximately 1500 RPM, the light should go off after a few seconds. If it does not, please consult your Authorized Cobalt Dealer.
25. Motor box electric actuator — Controls motor box electrically. If battery is low or disconnected, the motor box can be raised manually. Simply grasp the lower forward edge of the assembly and raise.

**NOTE: The motor box assembly is very heavy. Caution should be exercised when opening manually.**

26. Hour meter — Indicates engine running time.
27. Ignition safety switch — All Cobalts are equipped with an ignition safety switch. Included is a lanyard with a clip to attach the lanyard to the driver. This safety device should be used at all times. If the driver leaves the driver's station, the lanyard will actuate the switch and shut off the engine.

**NOTE: If this occurs, the engine must be placed in neutral and restarted immediately to prevent internal damage to the engine. Please consult your Cobalt dealer for further information.**

## **7. Engine Control**

The engine controls shifting, throttle and in most cases incorporates the power trim control which is covered in another section entitled "Power Trim".

**NOTE: We cannot overemphasize the importance of proper use of the throttle/shift control, espe-**

**cially from the standpoint of safety. Please consult the engine owner's manual supplied with your new Cobalt or consult your Authorized Cobalt Dealer for specific instructions about your throttle/shift control.**

The following are general instructions:

#### **SIDE MOUNT CONTROL**

The engine will start only in neutral. To move handle from neutral position squeeze the button on the handle and move handle. Moving handle forward engages forward gear initially.

Continuing forward movement will advance throttle. Moving handle aft engages reverse gear initially. Continued aft movement will advance throttle.

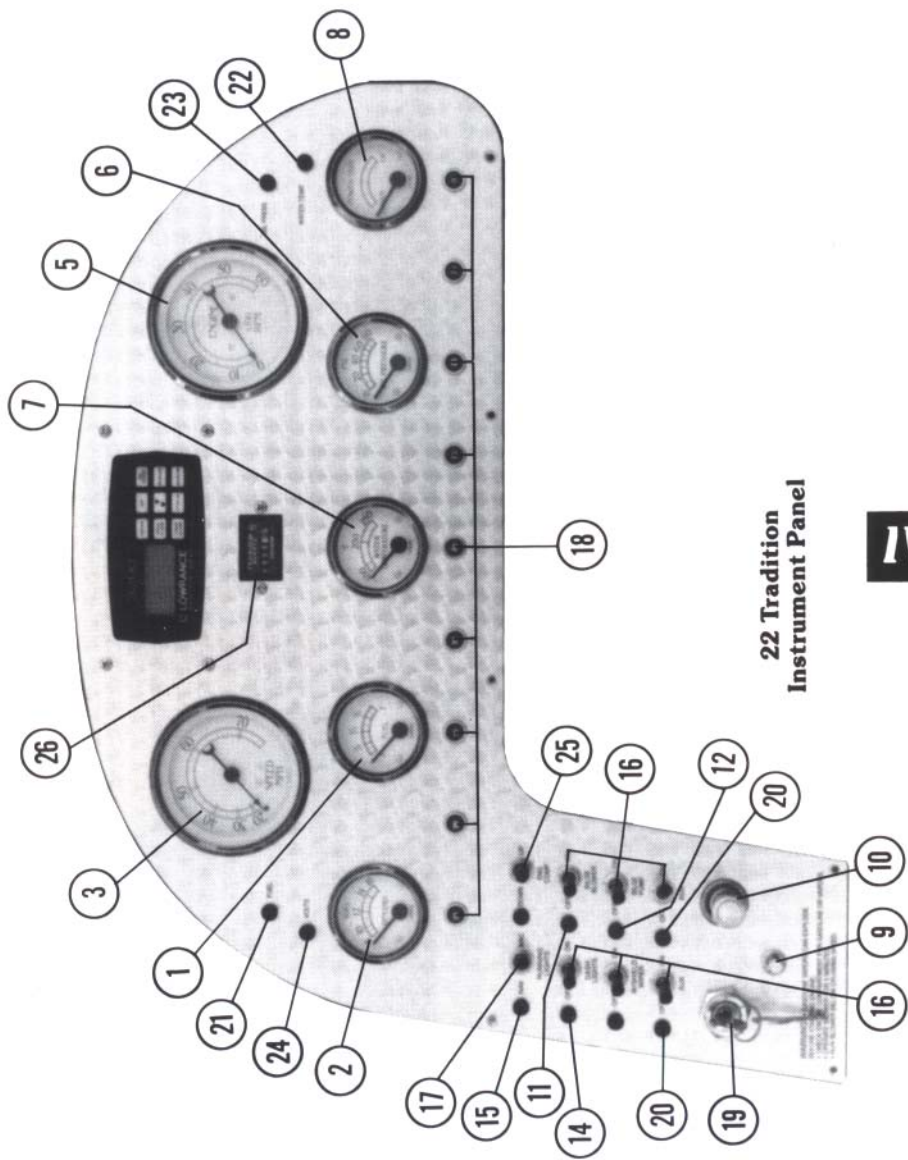

**22 Tradition  
Instrument Panel**

### Condurre Dash Panel

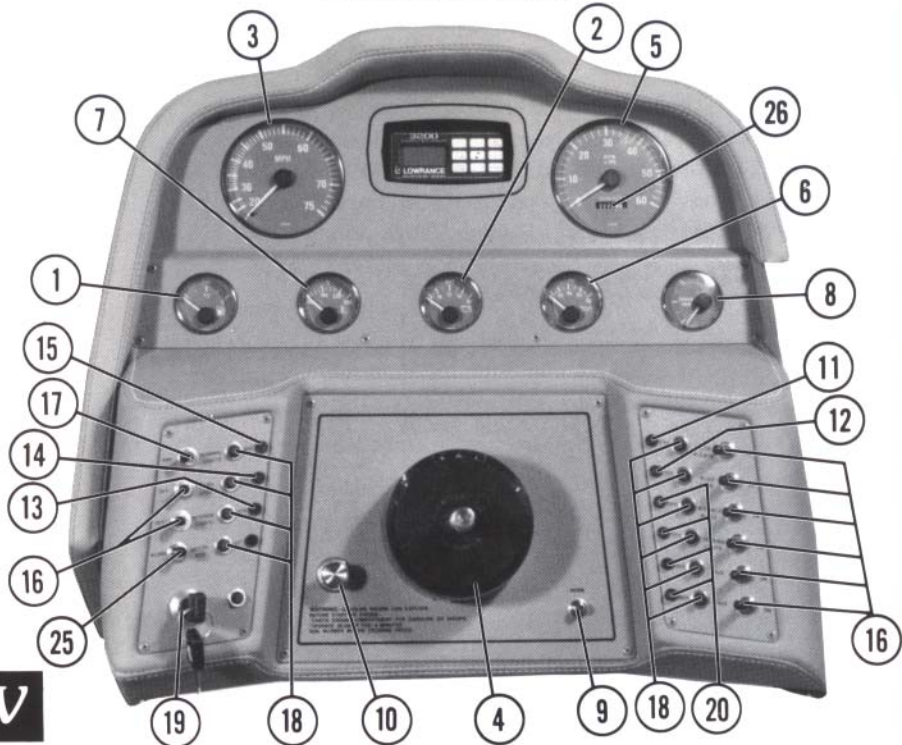

### 196/198 Dash Panel



**IV**

Cold Starting — While handle is in the neutral position, depress button in the center of the bottom of the handle and move forward. Please consult the engine owner's manual.

**WARNING: JAMMING THE THROTTLE INTO THE FORWARD OR REVERSE POSITION CAN CAUSE A SUDDEN, UNCONTROLLABLE BURST OF SPEED. DO NOT JAM THE THROTTLE LEVER FORWARD OR BACKWARD.**

### **KIEKHAEFER CONTROL (OPTIONAL)**

The optional Kiekhaefer Control is a two lever control using separate levers for the throttle and shift functions. The control does provide start in neutral only protection but does not provide protection against shifting at above idle speeds. Great caution must be used when using this control. Only shift with the engine at a dead idle (700 RPM or less). Shifting above dead idle (either into or out of gear) can cause premature wear of the shift mechanism in your stern drive assembly. It also can create a safety hazard condition. Do not shift your Kiekhaefer controlled Cobalt above a dead idle position.

**WARNING: SHIFTING THE SHIFT LEVER AT ANY ENGINE SPEED ABOVE DEAD IDLE (700 RPM OR LESS) CAN CAUSE SUDDEN, UNCONTROLLABLE BURSTS OF SPEED.**

## **8. Steering System**

The steering system in your Cobalt is the finest available in the boating industry today. It is a mechanical system, with power assist in all installations.

### **Steering/Propeller Torque**

Steering or propeller torque is always present in any drive system. In some systems, it is more noticeable than in others. Your boat has power steering and you should not encounter this torque to any significant degree. If you encounter movement in the steering wheel when released, please check with your dealer. It may be necessary to adjust the power steering assembly or torque tab on the drive unit. These adjustments should only be made by a qualified service person. The steering system in your Cobalt is one of the most important systems and should be checked on a regular basis by an Authorized Cobalt Service

Dealer for proper operation.

### **Wandering/Fishtailing**

Wandering is a characteristic of all deep vee bottom boats at slow speed. There is no cure for wandering, however, a very basic operational technique can be applied which will minimize this characteristic. If the steering wheel is moved back and forth to compensate for wandering, invariably, the situation will be accentuated. If the steering wheel is left in a centered position, the boat will wander back and forth slightly, however, the overall course of the boat will be a straight one.

**WARNING: THE STEERING IS THE MOST IMPORTANT SYSTEM IN THE ENTIRE BOAT FROM A SAFETY STANDPOINT. HAVE THIS SYSTEM INSPECTED AND MAINTAINED ON A FREQUENT, PERIODIC BASIS BY A QUALIFIED SERVICE TECHNICIAN.**

## **IV**

### **9. Power Trim**

#### **General**

The power trim changes the drive unit angle in reference to the transom of the boat. Regardless of engine type, a few basic operating techniques should be applied.

1. The drive unit should be lowered fully prior to initial acceleration.
2. After the boat has attained planing speed (18-24 MPH), the trim should be raised for maximum speed and handling characteristics.
3. If the trim is raised too high, porpoising (bouncing) and cavitation (propeller slippage) can occur.
4. It will be necessary to readjust the trim angle as boat speed changes and the attitude of the boat changes.

### **10. Warning Labels**

Your Cobalt has several warning labels displayed to point out safety hazards. The areas are as follows:

#### **a. Boarding Ladder/Swim Platform**

“WARNING: Under no circumstances should anyone be allowed to enter or exit your Cobalt from the boarding ladder or swim platform while engine is running.”

**b. Engine Flame Arrestor**

“Leaking fuel is a fire and explosion hazard. Inspect fuel system regularly. Examine fuel tank for leaks or corrosion at least annually.”

**c. Dashboard**

“Operate Bilge Blower at least two minutes before starting engine. Run continuously during starting and below cruising speeds.”

**d. Windshield Wing, Driver's Side Cobalt Check List**

For maximum enjoyment and safety, check each of these items BEFORE you start your engine:

- DRAIN PLUG (Securely in place?)
- LIFE-SAVING DEVICES (One for every person on board?)
- STEERING SYSTEM (Working smoothly and properly?)
- FUEL SYSTEM (Adequate fuel? Leaks? Fumes?)
- BATTERY (Fully charged? Proper water level?)
- ENGINE (In neutral?)
- CAPACITY PLATE (Are you overloaded?)
- WEATHER CONDITIONS (Safe to go out?)
- ELECTRICAL EQUIPMENT (Lights, horn, pump, etc.?)
- EMERGENCY GEAR (Fire Extinguisher? Bailer? Paddle? Anchor and Line? Signalling Device? Tool Kit? Etc.?)

**e. Recommended Safety Rules**

- REMAIN SEATED WHILE UNDERWAY.
- AVOID USING REAR PAD OR SUNDECK WHILE ENGINE IS RUNNING.
- DO NOT USE BOARDING LADDER WHILE ENGINE IS RUNNING.
- TURN OFF ENGINE AND ALL ELECTRICAL SYSTEMS WHILE RE-FUELING.
- TURN OFF ENGINE(S) WHEN SWIMMERS ARE NEAR BOAT.

**WARNING: MANEUVERABILITY ABOVE 50 MPH IS LIMITED. SUDDEN TURNS MAY CAUSE LOSS OF CONTROL. (NOT ALL**

## **BOATS ARE REQUIRED TO HAVE THIS DECAL).**

### **11. High Speed Operation**

#### **a. Maneuverability**

When operating any boat at high speed, a great deal of caution must be exercised. This is particularly true during turns. Gradual turns can be completed at high speed by a competent driver but it must be emphasized that sudden turns at any speed and particularly at high speed can be especially dangerous. It is possible to throw passengers from their seats and even from the boat if caution is not exercised. Remember, common sense is the rule for safe boating.

**WARNING: WAKE JUMPING — YOUR COBALT IS NOT DESIGNED FOR WAKE JUMPING. WHEN CROSSING ANOTHER BOAT'S WAKE, THROTTLE BACK TO PREVENT YOUR BOAT FROM LEAVING THE WATER. WAKE JUMPING IS VERY DANGEROUS. IT IS POSSIBLE FOR THE BOAT TO RE-ENTER THE WATER ON ITS SIDE, TRANSOM, OR BOW. YOU AND YOUR PASSENGERS COULD SUFFER SERIOUS INJURY. ALSO, DAMAGE TO THE BOAT COULD TAKE PLACE CAUSING A HAZARDOUS CONDITION.**

### **12. Lifting Your Cobalt**

The boweye and transom rings have the capacity to lift your Cobalt.

Keep in mind however, that there is a proper way to lift your Cobalt. Lifting pressure must always be vertical. Improper lifting could cause damage. If only one hoist is used, a spreader bar must be employed to avoid side strain on the rings.

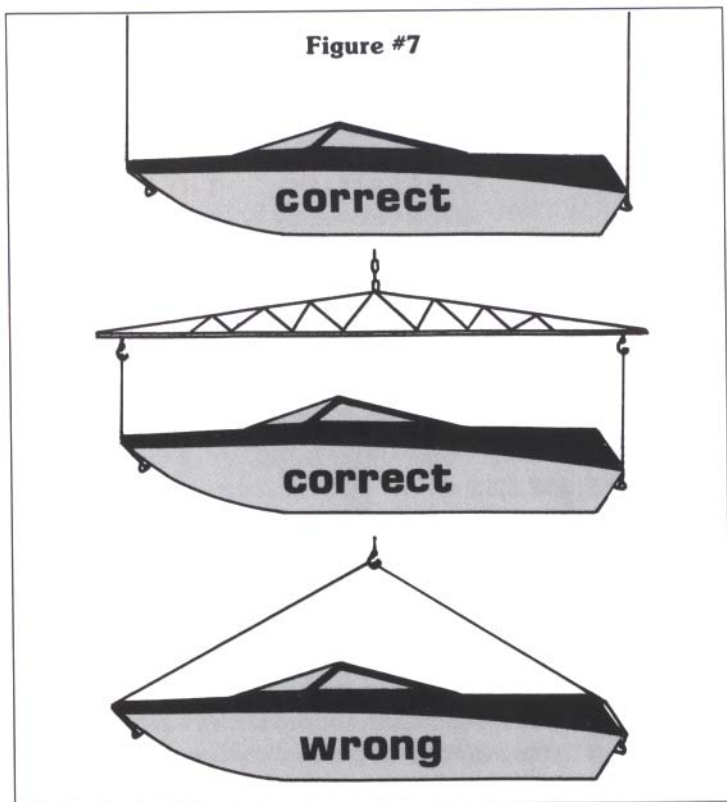

**CAUTION: RINGS MUST NOT BE USED FOR STORAGE. AFTER YOUR COBALT IS LIFTED INTO POSITION, SUPPORT MUST BE PLACED UNDER THE HULL AND ALL OF THE WEIGHT REMOVED FROM THE RINGS. FOR FURTHER INFORMATION, PLEASE CONTACT YOUR COBALT DEALER. FIGURE 7 ILLUSTRATES THE CORRECT AND INCORRECT HOOK-UP FOR LIFTING.**

**WARNING: THE SKI TOW MOUNTED ON THE CONDURRE MODELS CANNOT BE USED TO LIFT THE BOAT. IT CAN ONLY BE USED FOR WATER SKIING. IT IS NOT STRESSED FOR TOWING ANOTHER BOAT OR FOR PARASAILING. THE TRANSOM MOUNTED EYES SHOULD BE USED FOR PULLING A HEAVIER LOAD.**

### **13. Trash Receptacle**

#### **Most Models**

To remove this compartment, first open fully. Then lift up and pull out from the bottom. After it clears the lower lip, lower and remove. Then disconnect the expansion cord from the back of the compartment. To reinstall, reverse the procedure.

#### **22T, 222, 252**

To remove, open hanging locker door and release the expansion cord from the back of the trash receptacle. The receptacle can then be removed.

### **14. Fold Down Boarding Ladder**

**THIS LADDER MUST ONLY BE USED WHILE ENGINE IS OFF.** (See warning label section). To lower, unsnap securing strap, and lower. Be sure ladder is raised and secured prior to starting engine. Caution should be used while using this ladder, in that any substance can be slippery when wet.

**WARNING: DO NOT USE BOARDING LADDER WHILE ENGINE IS RUNNING.**

**CAUTION: THE STERN DRIVE UNIT HAS MANY SHARP EDGES, ESPECIALLY THE PROPELLER. EXERCISE CAUTION WHEN NEAR THE STERN DRIVE UNIT.**

### **15. Water Ski Towing**

The ski tow hook may be used for one or more lines for water ski towing only.

**WARNING: WHENEVER A SKIER OR SWIMMER IS CLOSE TO THE BOAT, SHUT OFF THE ENGINE TO PREVENT SERIOUS INJURY.**

**WARNING: THE SKI TOW MOUNTED ON THE CONDURRE MODELS CANNOT BE USED TO LIFT THE BOAT. IT CAN ONLY BE USED**

**FOR WATER SKIING. IT IS NOT STRESSED FOR TOWING ANOTHER BOAT OR FOR PARASAILING. THE TRANSOM MOUNTED EYES SHOULD BE USED FOR PULLING A HEAVIER LOAD.**

**CAUTION: THE STERN DRIVE UNIT HAS MANY SHARP EDGES, ESPECIALLY THE PROPELLER. EXERCISE CAUTION WHEN NEAR THE STERN DRIVE UNIT.**

## **16. Deck Hatch**

### **Cabin Models**

The deck hatch is manually operable. To open, simply release the one or two hasps on the forward edge of the hatch, make sure the support bracket adjusters are loose, and raise the hatch to the desired position and secure the adjusters.

**CAUTION: DO NOT USE A RAISED HATCH FOR A SUPPORT OR HAND HOLD WHILE ON THE DECK.**

**IV**

## **17. Engine Accessibility**

### **Condurres — Motor box/Jump seat interior**

Open engine box by using handle. **Do not lift** on the underside of the jump seat cushion. When closing the motor box, do not allow the box to “slam shut”.

### **All Others**

Motor box lid is electrically controlled. Make sure battery switches are turned on and operate the appropriate switch on the dash. If the battery is dead, you can lift the hatch by hand (the hatch is quite heavy and caution should be exercised that it does not fall on hands or arms). The electric mechanism automatically disconnects.

**NOTE: All electrically controlled motor boxes have one or two manual stainless steel prop rods. After opening an electric motor box, either electrically or manually, unhook the rod and place it in its receptacle on the floor (272-side panels). This is for safety and will prevent the motor box from coming down due to an electric actuator failure.**

## 18. Fuel Filling

**WARNING: YOUR FUEL SYSTEM SHOULD BE CHECKED BEFORE EACH OPERATION. AT LEAST ONCE A YEAR, HAVE A THOROUGH CHECK OF YOUR FUEL SYSTEM BY A CERTIFIED COBALT SERVICE MAN. GASOLINE IS HIGHLY FLAMMABLE; EXTREME CAUTION SHOULD BE USED AT ALL TIMES.**

The fuel system in your Cobalt is externally vented. This allows air into the fuel tank as the engine uses fuel and allows air out of the tank as the tank is being filled. The vent fitting is on the back of the boat and is chrome in appearance.

When filling your Cobalt, a small amount of overflow can occur when the tank becomes full. Be prepared to wash down the area to protect the fiberglass finish and the gunwale trim. The trim is made of a vinyl material and fuel may stain it if not cleaned promptly.

**WARNING: GASOLINE IS HIGHLY FLAMMABLE. USE EXTREME CAUTION WHEN HANDLING GASOLINE!**

## 19. Ignition Safety Switch

Your Cobalt is equipped with an ignition safety switch. It is located on the lower lip of the dashboard and is equipped with a lanyard and snap hook.

The driver should always attach the lanyard to his or her person. If the driver leaves the driver's station, the lanyard will shut off the ignition immediately preventing the boat from moving farther under power.

If the lanyard is lost, the switch may be overridden for temporary engine operation but only in emergencies. Contact your Cobalt dealer immediately if a replacement lanyard is needed.

**CAUTION: DO NOT ALLOW YOUR COBALT TO BE OPERATED WITHOUT THE PROPER USE OF THE IGNITION SAFETY SWITCH AND LANYARD.**

## 20. 272 Condurre

### a. Battery Switch

1. Your 272 Condurre is equipped with a vapor proof on/off battery switch. When in the off position, all electrical circuits, including the automatic bilge pump, are inoperable.
2. Do not turn this switch off with the engine running or damage to the engine's ignition system and battery charging system may occur.

### b. Head compartment

1. Make sure the head compartment door assembly is closed and latched while the boat is underway. Do not allow to swing freely.
2. The light also turns on the ventilation blower.
3. For operation of porta potti, pump out, or macerator, please check the manuals supplied in your owner's packet.

### c. Side Bench Seat

1. This seat can only be used with the motor box in the closed position.
2. To open, pull support leg out and down. Then slide seat assembly away from the side of the boat.
3. To close, simply reverse the process.

**NOTE: Do not attempt to raise the motor box with this seat open or damage to the seat will occur.**

### d. Retractable swim platform.

1. The battery switch must be in the "ON" position to operate the platform.
2. Can be raised or lowered by operating the toggle switch on the upper back deck or by the second switch under the lower edge of the platform on the port side.
3. Before raising platform, make sure the boarding ladder is completely stowed and the retaining strap is fastened in place.

**WARNING: Make sure the engine is shut off before using the swim platform.**

## 21. Optional Equipment

### a. Swim Platform (Tradition only)

The swim platform **cannot** be jumped on. Jumping on the swim platform can be dangerous and can also do permanent damage to the structural integrity of the mounting brackets.

**WARNING: MAKE SURE THE ENGINE IS SHUT OFF BEFORE USING SWIM PLATFORM.**

### b. Camper Top

See Section IV Boat Operation 1. Canvas.

### c. AM/FM Stereo Cassette

There are separate instructions in the owner's packet that give specific instructions for operation.

### d. Remote Control Spotlight

1. Has both flood and spot beams controlled by a three position switch on the spotlight control panel.

**NOTE: The spotlight control panel has two (2) fuses behind it accessible by removal of the panel itself. The fuses are for the bulb and the spotlight motor.**

2. Rotates more than 360 degrees and will travel up and down by using "joy stick" control.
3. Speed at which spotlight moves is controlled by the black knurled knob.

### e. Docking Lights

Docking lights are to be used for docking only. It is illegal to use your docking lights away from docks, the shoreline, etc. Please consult with your Cobalt dealer for further information.

### f. Trim Tabs

The trim tabs are a separate system in themselves and are not to be used in lieu of the engine power trim system.

1. Before accelerating, make sure the tabs are both fully raised.
2. Do not use the tabs until the boat has reached the desired speed and the power trim has been adjusted to the proper setting.

3. Operate only one tab at a time and in small increments. As the tab takes effect, you will notice it causes the boat to veer off course slightly. Correct for this as it happens. In other words, it will be necessary to use the trim tab and steering simultaneously.

Basic operating techniques — Bow high attitude

1. Make sure both tabs are fully raised.
2. Lower both tabs simultaneously for approximately five seconds.
3. Accelerate the boat to planing speed and see if the desired effect is attained.
4. If not, raise or lower both tabs until desired attitude is obtained.
5. After desired attitude is obtained, one trim tab may be adjusted independently of the other to compensate for listing.
6. Make it a habit to raise both tabs each time the boat is slowed to less than planing speed.

**NOTE: If in doubt, raise the tabs completely and start over again.**

#### **g. Extra Battery and Switch**

This option gives you the ability to isolate the entire boat from the batteries, and switch to either or both batteries. Under normal situations, the switch should be in “position 1” or “position 2” rather than the “all” position. This will keep one battery in reserve should the other fail. Battery selection should be made with engine off only. We recommend alternating batteries on a daily basis.

#### **h. Portable Head**

Please consult the owner’s manual supplied with the head for proper operation.

**V. Propellers and Propeller Chart . . . . . 45**

## V. PROPELLERS AND PROPELLER CHART

### Propellers — General

Nothing is more important to the proper performance of your boat than the condition of the propeller(s). Even minor damage (often invisible to the naked eye) can adversely affect the boat's performance. Common symptoms of damage to propellers are a sudden drop in RPM, vibration or sudden loss of speed.

A propeller is measured by two dimensions: 1) the diameter; and, 2) the pitch. The diameter is determined by measuring the distance from the center of the propeller to the tip of one blade and multiplying that figure by two. Pitch is expressed in the number of inches a prop will advance in a solid medium in one revolution.

Operational characteristics of your boat, including its speed, may change due to several factors: atmospheric conditions; additions of extra equipment and accessories or passengers; marine growth on the bottom; and, engine condition. Other factors include damage to the prop(s), tides, water temperature and direction of wind. Some of these factors are directly correctable by repair or maintenance. Others are beyond human control. A few which may be considered permanent operating conditions may be compensated for by a change in prop(s). Such a change should not usually be undertaken without the advice of your dealer. Unless you are prepared to spend much time and money on hit and miss methods of prop selection, it is strongly recommended that you talk with your Cobalt Dealer.

**CAUTION: INCORRECT PROPELLER APPLICATION CAN CAUSE ADVERSE HANDLING CHARACTERISTICS. DO NOT CHANGE TYPE OR SIZE OF PROPELLER WITHOUT CONSULTING YOUR COBALT DEALER!**

### Stainless Steel

For the ultimate in top speed, stainless steel propellers will increase top speed by two to four MPH. However, they will do so at the sacrifice of some of the pulling power for water skiing and heavy loads. Stainless steel propellers should only be used when additional speed is desired. Under normal usage, aluminum propellers will give you the best overall performance. Keep in mind that if hitting a submerged object, aluminum will bend easier than stainless, absorbing most of the shock and help protect the stern drive. Stainless steel may not bend and transmit the shock into the drive which could cause

internal drive damage. For further information, please consult your Cobalt dealer.

Some Cobalts are standard equipped with stainless propellers. In this instance, do not substitute aluminum propellers. Adverse handling and top speed characteristics may be experienced.

### **Pulling Power**

If you need extra pulling power, you can obtain this by decreasing the pitch of your propeller(s) by two degrees. This will not endanger the engine or drive unit as long as the manufacturer's recommended top RPM's are not exceeded.

## 1993 PROP CHART ALUMINUM

	196/198	206	22T	222/223	243	252/255	272
4.3 Mer	13 $\frac{3}{4}$ x21C 48-78122A40	14x19C 48-78120A40	N/A	N/A	N/A	N/A	N/A
4.3 Mer LX	13 $\frac{3}{4}$ x21C 48-78122A40	14x19C 48-78120A40	N/A	N/A	N/A	N/A	N/A
432 Volvo S/P	N/T	N/T	N/A	N/A	N/A	N/A	N/A
432 Volvo D/P	B-8 853638-5	N/A	N/A	N/A	N/A	N/A	N/A
434 Volvo S/P	N/T	N/T	N/A	N/A	N/A	N/A	N/A
434 Volvo D/P	B-7 853637-7	N/A	N/A	N/A	N/A	N/A	N/A
4.3 Yamaha PSRA	N/T	N/T	N/A	N/A	N/A	N/A	N/A
4.3 Yamaha YEMSR	N/T	N/T	N/A	N/A	N/A	N/A	N/A
5.0 Litre Mer	14x19C 48-78120A40	14x19C 48-78120A40	N/A	N/A	N/A	N/A	N/A
500 Volvo S/P	N/T	N/T	N/A	N/A	N/A	N/A	N/A
500 Volvo D/P	N/T	N/A	N/A	N/A	N/A	N/A	N/A
5.0 Yamaha PSRA	14 $\frac{1}{2}$ x17 6G5-45947-01-98	N/T	N/A	N/A	N/A	N/A	N/A
5.7 Litre Mer	14x19C 48-78120A40	13 $\frac{3}{4}$ x21C 48-78122A40	14x19C 48-78120A40	13 $\frac{3}{4}$ x21C 48-78122A40	14x19C 48-78120A40	14 $\frac{1}{2}$ x17C 48-78118A40	N/A
570/572 Volvo D/P	B-6 853635-1	N/A	B-6 853636-9	B-6 853636-9	B-6 853636-9	B-5 853635-1	N/A
572 Volvo S/P	N/T	N/T	N/T	N/T	N/T	N/T	N/A
5.7 Yamaha PSRA	N/T	14x19 6G5-45945-01-98	14x19 6G5-45945-01-98	N/T	N/T	N/T	N/A

ALL COBALTS WITH 7.4 LITRE ENGINE OR LARGER INCLUDE STAINLESS PROPS AS STANDARD EQUIPMENT

N/T — Not Tested    N/A — Not Available



# 1993 PROP CHART STAINLESS

	196/198	206	22T	222/223	243	252/255	272
4.3 Litre Mer	13% $\times$ 21C 48-16318A40	14x19C 48-16316A5	N/A	N/A	N/A	N/A	N/A
4.3 LX Mer	13% $\times$ 21C 48-16318A40	14x19C 48-16316A5	N/A	N/A	N/A	N/A	N/A
432 Volvo S/P	N/T	N/T	N/A	N/A	N/A	N/A	N/A
434 Volvo S/P	N/A	N/T	N/A	N/A	N/A	N/A	N/A
4.3 Yamaha PSRA	N/T	N/T	N/A	N/A	N/A	N/A	N/A
4.3 Yamaha YEMSR	N/T	N/T	N/A	N/A	N/A	N/A	N/A
5.0 Litre Mer	14x19C 48-16316A5	14x19C 48-16316A5	N/A	N/A	N/A	N/A	N/A
500 Volvo S/P	N/T	N/T	N/A	N/A	N/A	N/A	N/A
5.0 Yamaha PSRA	N/T	N/T	N/A	N/A	N/A	N/A	N/A
5.7 Litre Mer	14x19C 48-16316A5	13% $\times$ 21C 48-16318A5	14x19C 48-16316A5	13% $\times$ 21C 48-16318A5	14x19C 48-16316A5	14% $\times$ 17C 48-16314A5	N/A
572 Volvo S/P	N/T	N/T	N/T	N/T	N/T	N/T	N/A
5.7 Yamaha PSRA	N/T	N/T	N/T	N/T	N/T	N/T	N/A
7.4 Bravo Mer	N/A	N/A	14% $\times$ 23C 48-13704A40	14% $\times$ 23C 48-13704A40	14% $\times$ 21C 48-13702A40	14% $\times$ 21C 48-13702A40	15% $\times$ 19C 48-13700A40
7.4 Bravo III Mer	N/A	N/A	N/T	N/T	N/T	N/T	N/T
454 Mag Bravo	N/A	N/A	14% $\times$ 21C 48-13702A40	14% $\times$ 23C 48-13704A40	14% $\times$ 21C 48-13702A40	14% $\times$ 21C 48-13702A40	15% $\times$ 19C 48-13700A40
502 Mag Bravo	N/A	N/A	N/A	N/A	14% $\times$ 23C 48-13704A40	14% $\times$ 23LH 18-13705A40	13% $\times$ 21LH 48-13703A40
740 Volvo D/P	N/A	N/A	N/A	C-7 854391.0	C-6 854390.2	C-5 854389.4	C-5 854389.4
7.4 Yamaha PSRA	N/A	N/A	14% $\times$ 23RH 60U-45974-00-00	14% $\times$ 23LH 60U-45974-10-00	14% $\times$ 21LH 60U-45972-10-00	14% $\times$ 21LH 60U-45972-10-00	N/T

COBALT DOES NOT OFFER STAINLESS PROPS ON VOLVO 4.35.7 LITRE D/P'S

N/T — Not Tested N/A — Not Available

## **VI. Technical Information**

1. Engine Operation/ Maintenance/Serviceing . . . . .	50
2. The Break In Period . . . . .	50
3. Winterizing and Off-Season Storage . . . . .	50
4. Fuel Requirements . . . . .	51
5. Trouble Check Chart . . . . .	53
6. Wiring Diagrams . . . . .	57
7. Circuit Breakers . . . . .	57
8. Fuses . . . . .	57
9. Lighting/Bulb Replacement . . . . .	57
10. Specifications . . . . .	59

## VI. TECHNICAL INFORMATION

### 1. Engine Operation/Maintenance/Serviceing

Included with your owner's packet is your engine manual(s). This manual was prepared by the engine manufacturer and contains virtually everything you'll need to know concerning operation and care of your engine. Please read this manual thoroughly and become acquainted with this information.

It is advisable to maintain a service log to record service checks, such as oil changes, so you can determine when it's time for servicing.

### 2. The Break-In Period

We cannot stress enough, the importance of reading your engine manual(s) and following the manufacturer's instructions for breaking-in your engine(s).

Please see Section VII in this manual for further information pertaining to the break-in period and the 20-hour check.

### 3. Winterizing and Off-Season Storage

- a. It is vital that your Cobalt be stored with the bow slightly elevated; i.e., the same attitude as if the boat were floating at rest. If the boat is stored with the bow down, moisture will not be able to move to the engine bilge area and out of the boat. Mold and mildew may form as a result of the inability of moisture to escape. This can create structural damage to the internal stringer system as well as cause mold and mildew.
- b. Preparing for winter lay up is vital for the preservation of your Cobalt. In frigid zones, you must be particularly attentive to items that can be damaged by freezing. Freeze damage is not covered by warranty.
- c. Step by step instructions on what must be done to your engine(s) for winter storage is outlined in your engine manual(s). Follow these essential instructions carefully. This manual also details procedures for returning your engine(s) to service for in-season usage.
- d. Good storage is very important, be it indoors or outdoors. Proper storing or blocking is necessary to properly support the hull when stored dry. Most boat trailers provide sufficient support for long term storage.

- e. Provide adequate ventilation if canvas covered. Be sure there are openings at both ends so that a thru draft is created.
- f. Do not use convertible top, stern curtain, side curtains, cockpit tonneau cover, bow tonneau cover, camper top for storage. They will not provide ventilation nor are they designed to be waterproof. The only material that should be used for storage is army duck canvas such as Cobalt's optional Travel/Mooring Cover. Cobalt also advises against the use of temporary poly covers such as shrink wrap covers unless adequate ventilation is supplied.
- g. Remove battery. Store on wooden shelf or wood base. Store in dry, covered place, charged to capacity and check it periodically during the off-season. Recharge monthly.

**WARNING: BATTERY ACID CAN CAUSE BLINDNESS IF SPLASHED IN EYES, BURNING OF SKIN AND SEVERE GASTROINTESTINAL DAMAGE IF INGESTED. AVOID CONTACT WITH BATTERY ACID. USE EXTREME CAUTION.**

- h. Remove drain plug from transom.

#### **4. Fuel Requirements**

At Cobalt, we are most concerned with the safety aspect of the life of the fuel line between the fuel tank and the fuel inlet of the engine. This line is made of a synthetic, flexible material and although it is the best material available, alcohol can deteriorate it especially during periods of storage. For this reason, it is suggested that you have your Cobalt dealer inspect this fuel line at least annually and replace, if necessary.

The situation with fuels and the composition of fuel lines is changing very rapidly, therefore please keep in touch with your Cobalt dealer.

The performance of the engine may also be affected with the changing fuels. Please read your engine owners manual for recommended fuel usage.

**WARNING: YOUR FUEL SYSTEM SHOULD BE CHECKED BEFORE EACH OPERA-**

**TION. AT LEAST ONCE A YEAR, HAVE A THOROUGH CHECK OF YOUR FUEL SYSTEM BY A CERTIFIED, COBALT SERVICE MAN. GASOLINE IS HIGHLY FLAMMABLE; EXTREME CAUTION SHOULD BE USED AT ALL TIMES.**

## 5. Trouble Check Chart

### Trouble

Engine won't start

### Possible Cause

1. Lack of Fuel
2. Clogged anti-siphon valve
3. Clogged fuel tank pick-up
4. Clogged fuel filter
5. Plugged fuel line or defective pump.
6. Carburetor float valve stuck
7. Damp spark plugs
8. High tension leads wet and/or loose
9. No spark
10. No spark

### Action

- Check fuel.
- See Authorized Cobalt Dealer.
- See Authorized Cobalt Dealer.
- See Authorized Cobalt Dealer.
- Fuel pump may be defective. Inspect pump/sight glass for fuel leakage from fuel pump.  
See Authorized Cobalt Dealer.
- Tap float chamber with a screwdriver handle to free needle valve.
- Dry spark plug ceramic with clean, dry cloth.
- Dry and tighten connections at spark plugs, distributor and coil.
- Check for loose connections on coil.
- Check high tension lead on coil.

**WARNING: WHENEVER CHECKING FOR ELECTRICAL PROBLEMS USE EXTREME CAUTION. GASOLINE IS FLAMMABLE!**

<b>Trouble</b>	<b>Possible Cause</b>	<b>Action</b>
	11. Water in fuel supply or old gasoline	Check fuel supply for water contamination. If gasoline is old or if water is present, drain fuel tank and flush with fresh gasoline <b>WARNING: GASOLINE IS FLAMMABLE USE EXTREME CAUTION WHEN HANDLING GASOLINE!</b>
	12. Ignition Safety Switch.	Your Cobalt is equipped with an ignition safety switch located on the lower lip of the dashboard. Make sure the lanyard is installed with the switch holding the lanyard in place.
Starter won't crank engine	1. Ignition Switch	If inoperative, see Authorized Cobalt Dealer.
	2. Throttle Position	Check to see that remote control is in start position. Change position of throttle only slightly.
	3. Dead battery	Check level of electrolyte, disconnect battery. Charge battery. <b>WARNING: BATTERY ACID CAN CAUSE BLINDNESS IF SPLASHED IN EYES; BURNING OF SKIN AND SEVER GASTROINTESTINAL DAMAGE IF INGESTED. USE EXTREME CAUTION.</b>

<b>Trouble</b>	<b>Possible Cause</b>	<b>Action</b>
	4. Battery connections loose or corroded 5. Starter connections loose	Check for loose connections and corrosion. Clean connections and tighten.  Check connections and tighten. If solenoid clicks when attempting to start engine, check battery connections. If condition persists, see your Authorized Cobalt Service Dealer.
Engine runs erratically	1. Automatic choke out of adjustment 2. Water and/or dirt in fuel filter	See your Authorized Cobalt Dealer  Clean and inspect filter.
	3. Fuel pump malfunction	<b>WARNING: GASOLINE IS FLAMMABLE. USE EXTREME CAUTION.</b>  Check operation of pump. Replace fuel pump. See your Authorized Cobalt Dealer.
	4. Fuel tank vent and line plugged	Check for restriction in line and vent. Blow out line and vent.
Engine vibrates	1. Propeller condition  2. Carburetor out of adjustment. 3. Spark plug condition	Check for bent, broken or damaged propeller. Check for weeds on propeller or gearcase.  See Authorized Cobalt Dealer.  Check spark plug electrodes and ceramic. Clean and regap. Replace plugs, if necessary.

Trouble	Possible Cause	Action
<p>Engine runs but boat makes little or no progress</p>	<p>4. High tension leads loose or deteriorated</p> <p>5. Incorrect firing order</p> <p>6. Engine out of time</p>	<p>See Authorized Cobalt dealer. Insure all connections are clean and tight.</p> <p>Correct firing order, see engine manufacturer's owner's manual.</p> <p>See Authorized Cobalt Dealer.</p>
<p>Engine runs but boat makes little or no progress</p>	<p>1. Fouled or damaged propeller</p>	<p>Stop engine. Check for weeds on propeller, bent or broken propeller. See your Authorized Cobalt Dealer.</p>
<p>Performance loss</p>	<p>1. Throttle not fully open</p> <p>2. Improper fuel</p> <p>3. Overheating</p>	<p>Check to see that throttle opens fully at carburetor.</p> <p>Fill tank with correct fuel.</p>
	<p>4. Boat overloaded</p> <p>5. Boat trim</p>	<p>Check cooling system. Remove weeds from water intake. Check alternator belt tension. Readjust rudder trim tab.</p> <p>Reduce load.</p>
	<p>6. Improper propeller selection</p>	<p>Distribute boat load evenly.</p> <p>Select proper propeller pitch and diameter. (See chart in owner's manual).</p>
	<p>7. Excessive bilge water</p> <p>8. Boat hull condition</p>	<p>Check for excessive water, drain bilge.</p> <p>Clean if marine growth is present.</p>

## 6. Wiring Diagrams

The diagrams on the following pages outline the electrical system. It is recommended that you let your Cobalt Dealer service any difficulties.

## 7. Circuit Breakers

Most electrical standard equipment devices are controlled with circuit breakers. These breakers will activate if overloaded and cut power to the switch. To restore power, simply push the breaker button in and release. (Breakers do not require fuse replacement).

## 8. Fuses

Some electrical components have in-line fuses with them. Check behind the failed component for the possibility of an in-line fuse if a tripped circuit breaker is not found.

Examples of in-line fuse components:

- In dash depth sounder
- Spotlight control
- Trim tab control
- Captain's call exhaust system  
(Fuse located on engine, starboard forward corner)
- Stereo

## 9. Lighting/Bulb Replacement

External Lights

- Bow Light Bulb(s) — #71
- Stern Light Bulb — #1004

Internal Lights

- Open Bulb Utility Light — #1004 or #211
- Cuddy Cabin Indirect Light — #211
- Cuddy Cabin Reading Light — #1141
- Black Rectangular Courtesy Light — #1044
- Chrome Courtesy Light (Round) — #90
- Overhead Console Light — GE 912
- Dome Light (255) — #211

Instrument Lights

- 196/198 Instruments
- Tachometer — 194 SF2
- Speedometer — 194 SD2
- Voltmeter — 658 S11

Oil Pressure — 658 SH2  
Temperature — 658 SC2  
Fuel — 658 SC2  
Trim — 658 SC2

206-272 Condurre

VDO Instruments use L.E.D.'s and are not replaceable.

22 Tradition

All bulbs — #600802

## SPECIFICATIONS

### 22T

Deadrise	20°
Centerline	22'0"
Beam	8'6"
Draft (Drive down)	36"
Freeboard FWD	48"
Freeboard AFT	42"
Transom Height	40"
Weight Dry	4000
Fuel Capacity	88 Gal.
Bridge Clearance w/o Nav Light	60"

### 196/198

Deadrise	20°
Centerline	19'6"
Beam	8'1½"
Draft (Drive up)	20"
Freeboard FWD	35"
Freeboard AFT	26½"
Transom Height	38"
Weight Dry	2800
Fuel Capacity	40 Gal.
Bridge Clearance w/o Nav Light	54"

### 206 CONDÚRRE

Deadrise	22°
Centerline	20'6¼"
Beam	8'2½"
Draft (Drive up)	18"
Freeboard FWD	36"
Freeboard AFT	21"
Transom Height	44"
Weight Dry	2800
Fuel Capacity	45 Gal.
Bridge Clearance w/o Nav Light	54"

### 222/223 CONDÚRRE

Deadrise	20°
Centerline	22'3"
Beam	8'5"
Draft (Drive up)	17"
Freeboard FWD	34½"
Freeboard AFT	21"
Transom Height	43"
Weight Dry	3400
Fuel Capacity	55 Gal.
Bridge Clearance w/o Nav Light	54"

## SPECIFICATIONS

**243  
CONDÚRRÉ**

Deadrise	20°
Centerline	23'10"
Beam	8'0"
Draft (Drive up)	20"
Freeboard FWD	38"
Freeboard AFT	24"
Transom Height	48"
Weight Dry	4100
Fuel Capacity	88 Gal.
Water Capacity	2½ Gal.
Bridge Clearance w/o Nav Light	64"

**252  
CONDÚRRÉ**

Deadrise	17°
Centerline	25'2"
Beam	8'6"
Draft (Drive up)	20"
Freeboard FWD	40½"
Freeboard AFT	25"
Transom Height	49"
Weight Dry	4300
Fuel Capacity	88 Gal.
Bridge Clearance w/o Nav Light	60"

**255  
CONDÚRRÉ**

Deadrise	17°
Centerline	25'2"
Beam	8'6"
Draft (Drive up)	20"
Freeboard FWD	44"
Freeboard AFT	27"
Transom Height	51½"
Weight Dry	4900
Fuel Capacity	83 Gal.
Water Capacity (Std. Int. Only)	10 Gal.
Bridge Clearance w/o Nav Light	66"

**272  
CONDÚRRÉ**

Deadrise	20°
Centerline	27'3 <sup>5</sup> / <sub>8</sub> "
Beam	8'6"
Draft (Drive up)	23"
Freeboard FWD	39"
Freeboard AFT	34"
Transom Height	52"
Weight Dry	4930
Fuel Capacity	97 Gal.
Water Capacity	10 Gal.
Bridge Clearance w/o Nav light	60"

Cobalt reserves the right to make changes in specifications, engine combinations and availability without prior notification or obligation.





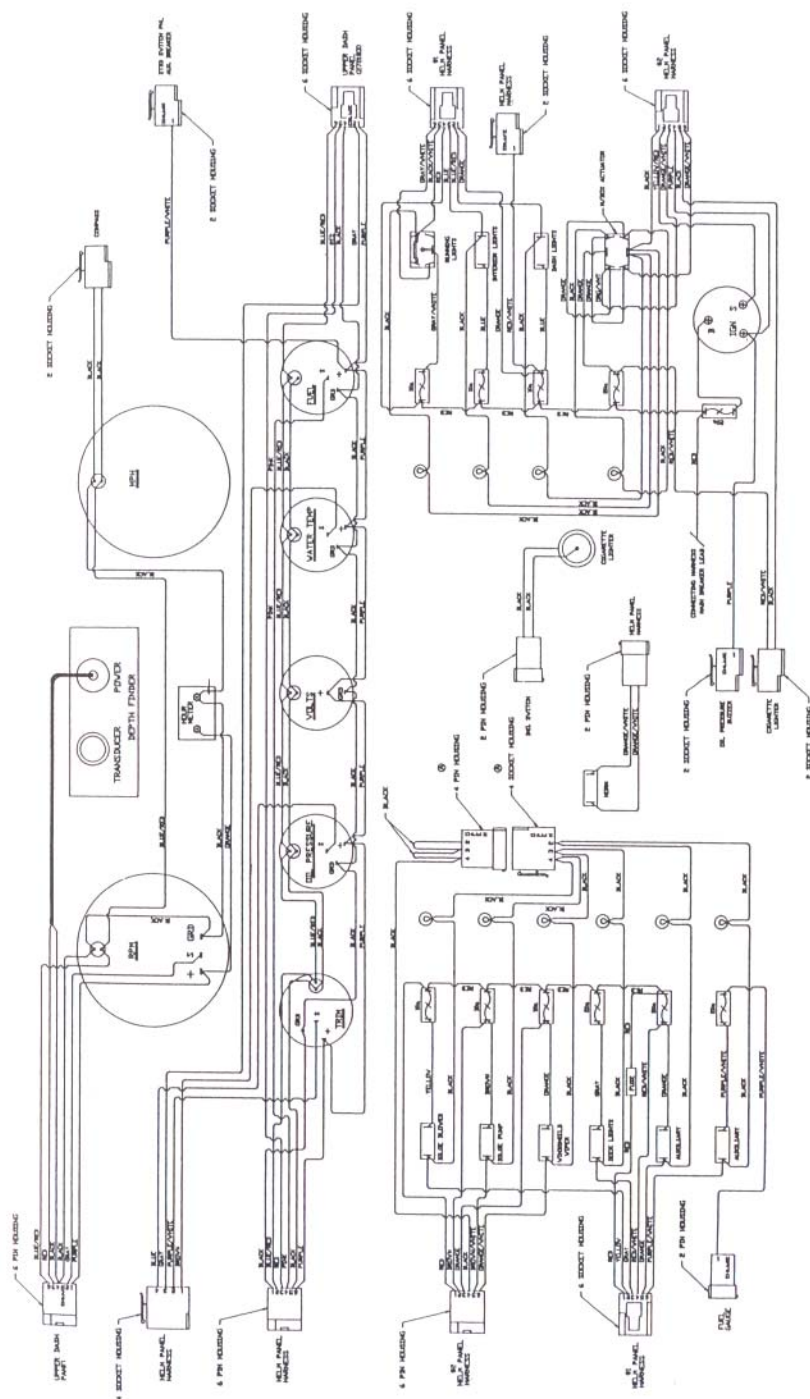

Dashboard  
206, 222, 223, 243, 252, 255, 272

VI

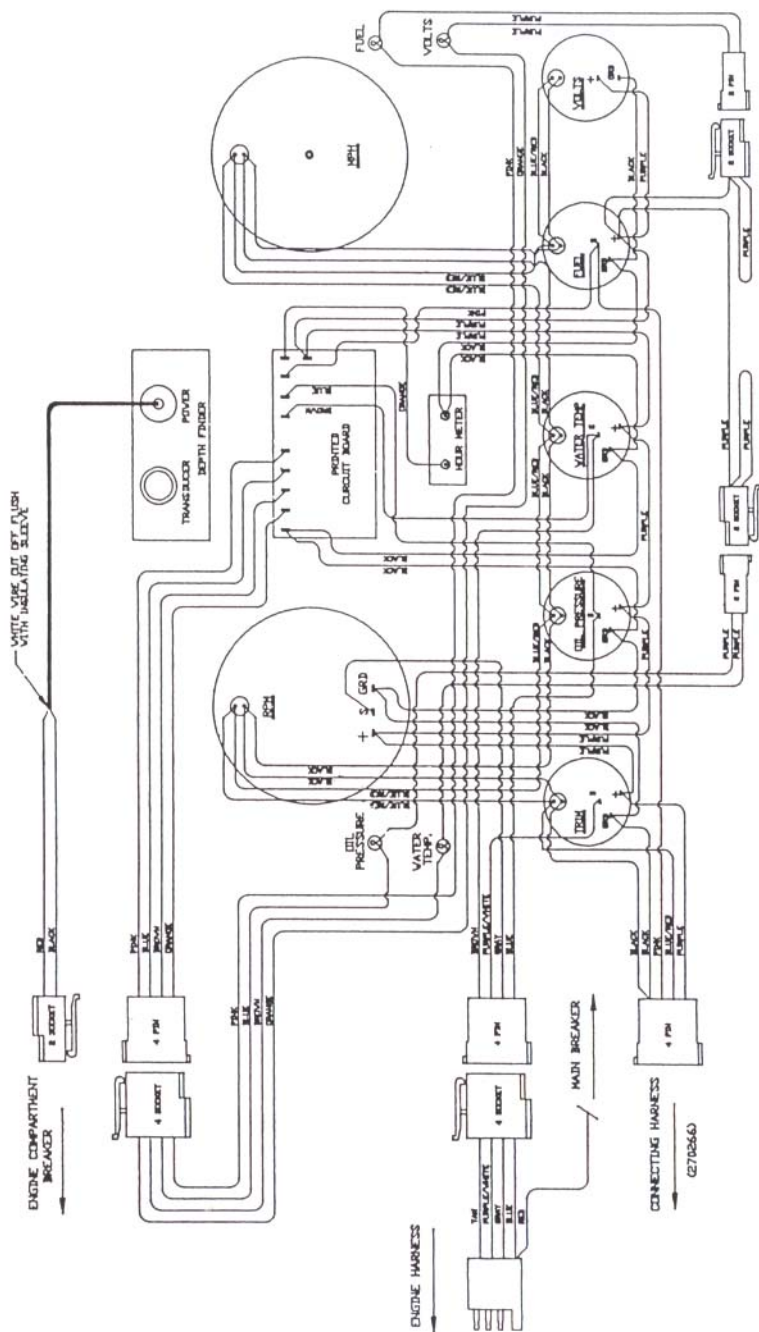

**Dashboard  
22 Tradition**

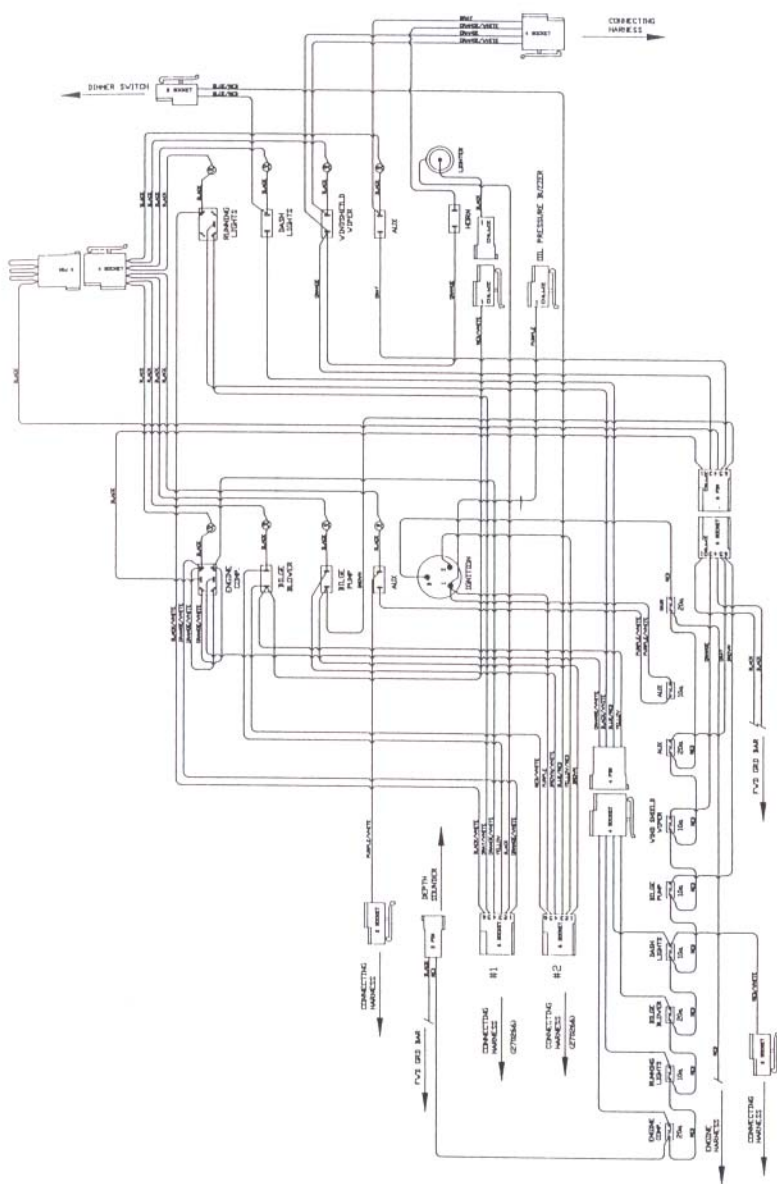

## Dashboard Switch Panel 22 Tradition





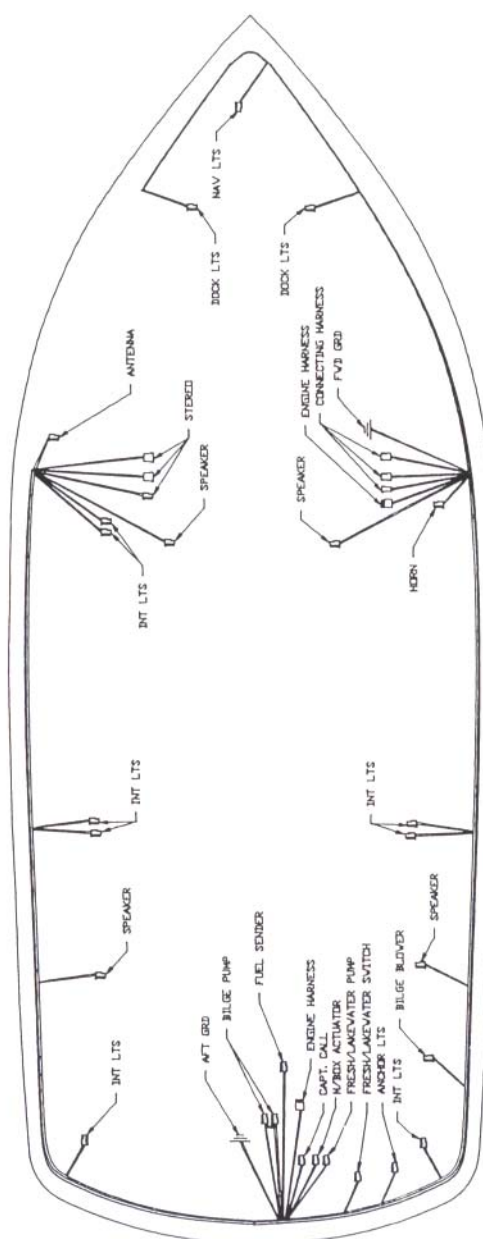

**Mainstream Harness  
Drop Locations  
206**

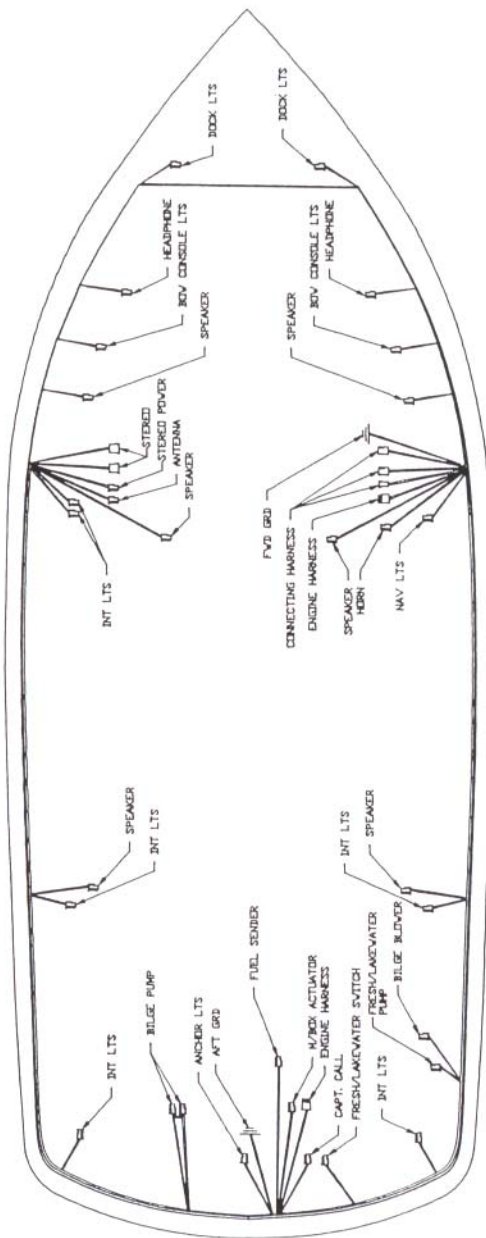

**Mainstream Harness  
Drop Locations  
222**

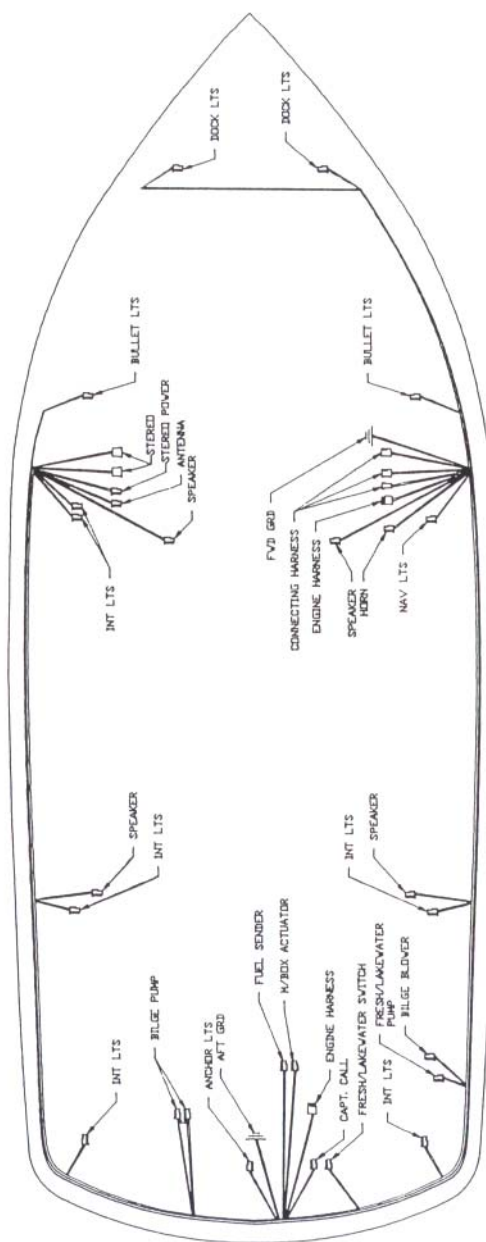

## Mainstream Harness Drop Locations 223

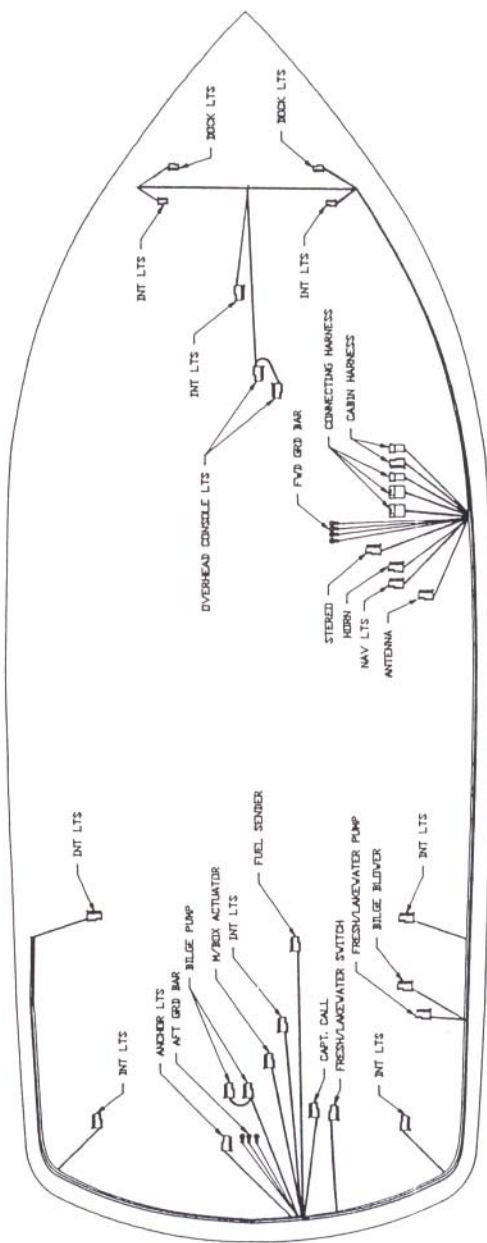

**Mainstream Harness  
Drop Locations  
243**



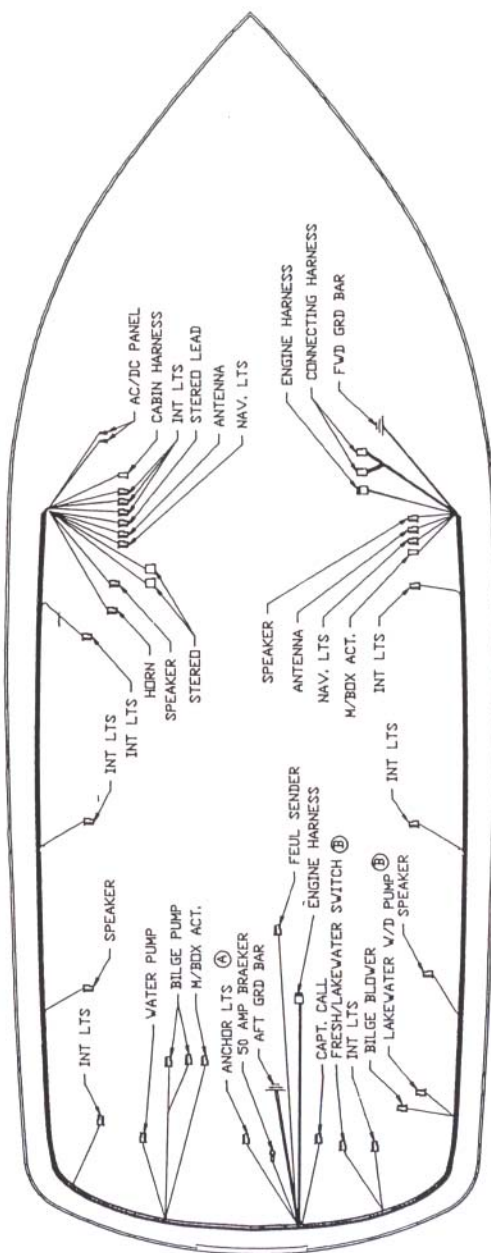

**Mainstream Harness  
 Drop Locations  
 255**

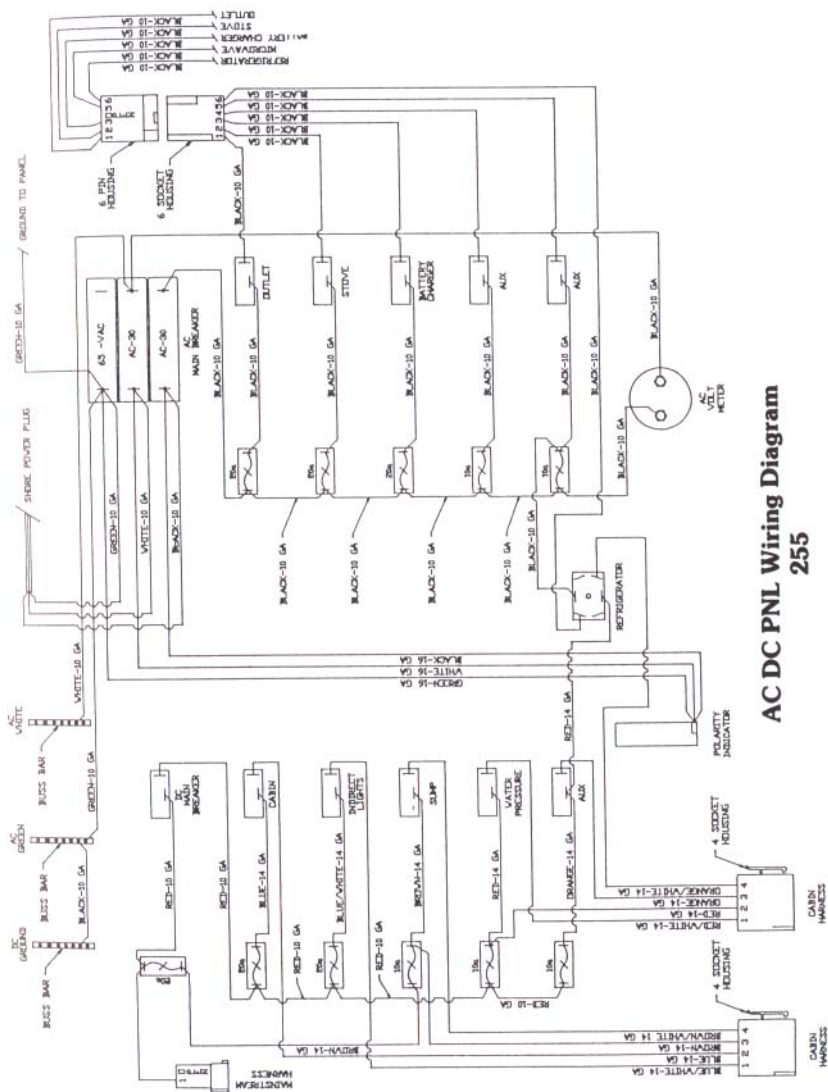

**AC DC PNL Wiring Diagram**  
255



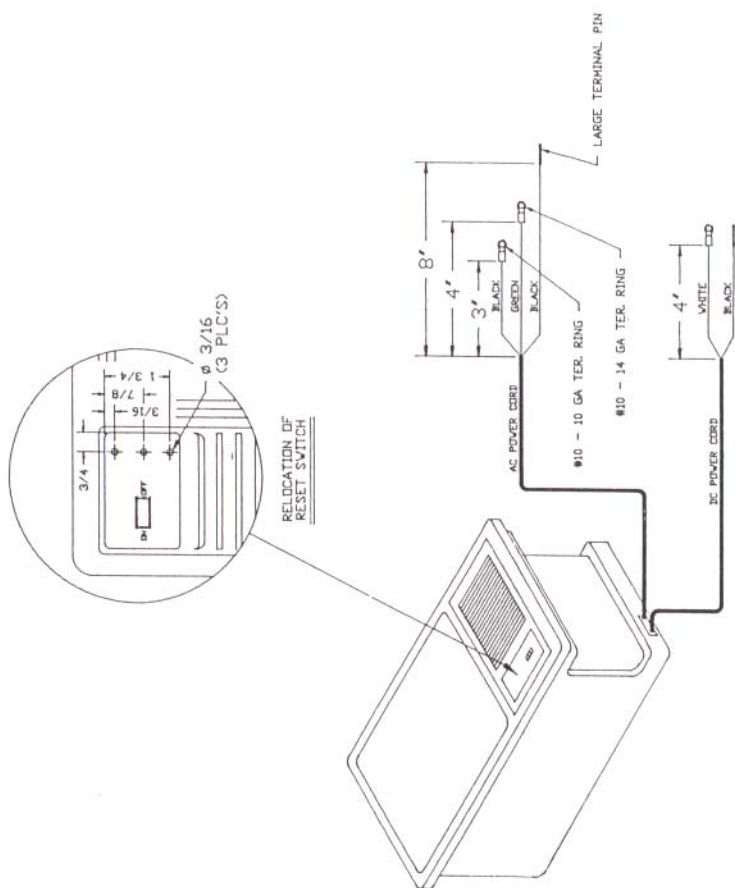

## Refrigerator Wiring 255

(FOR AUTOMATIC BILGE PUMPS)

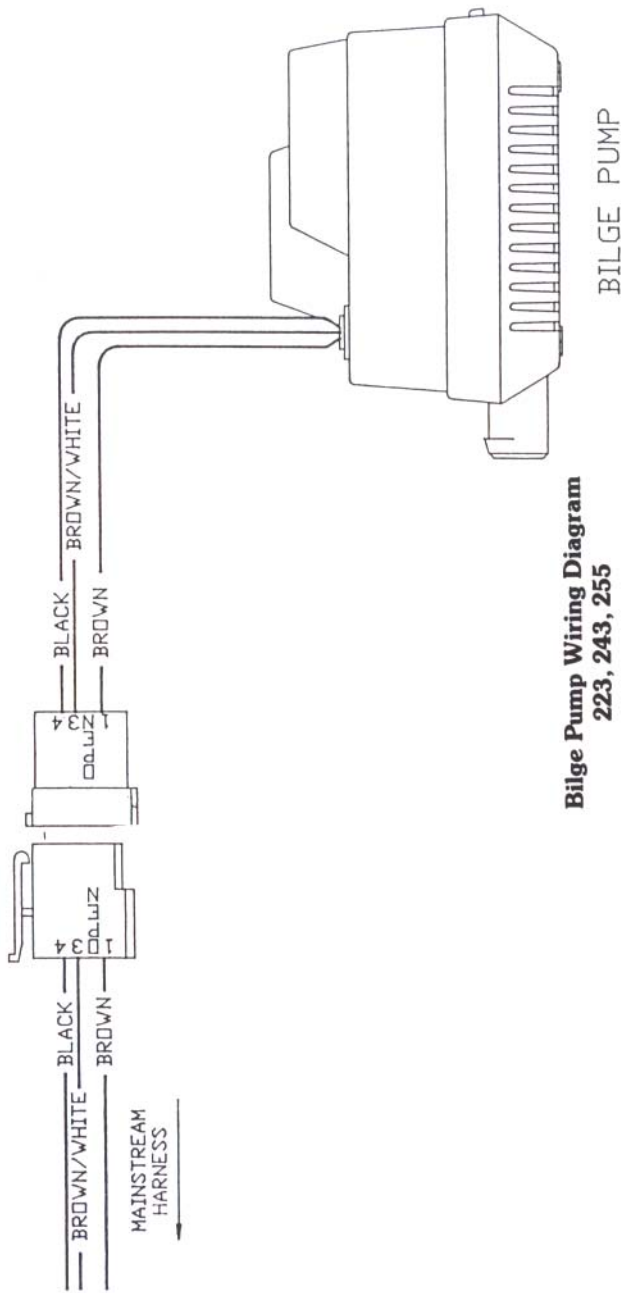

**Bilge Pump Wiring Diagram**  
223, 243, 255

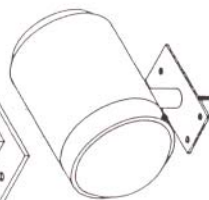
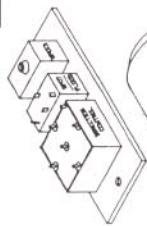

PART #	DESCRIPTION	QTY
41525A	6 SOCKET WELDING	1
41563	6 PIN WELDING	1
415145	2 PIN WELDING	2
41537	2 SOCKET WELDING	1
17065	SMALL TERMINAL SOCKET	3
17066	MEDIUM TERMINAL SOCKET	6
17067	LARGE TERMINAL SOCKET	1
17004	14 GA BLACK TERMINATOR	4*

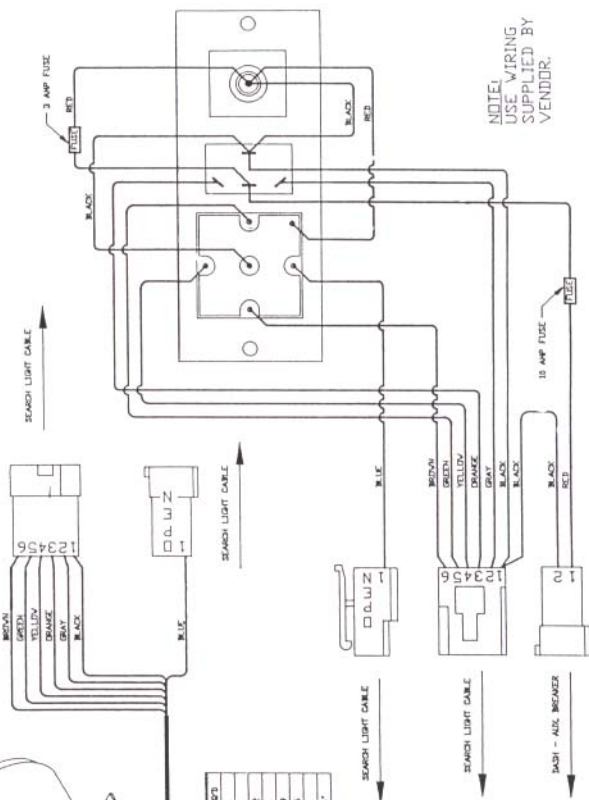

NOTE:  
USE WIRING  
SUPPLIED BY  
VENDOR.

**Searchlight Wiring Diagram**

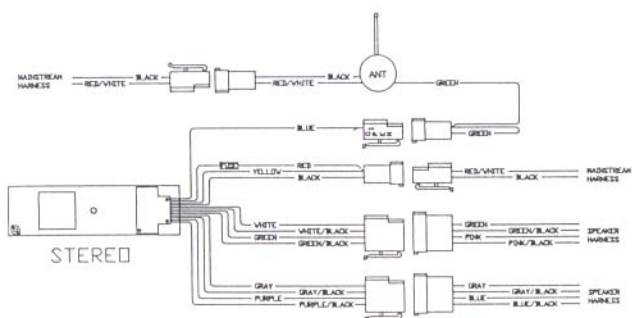

### Stereo Wiring Procedure

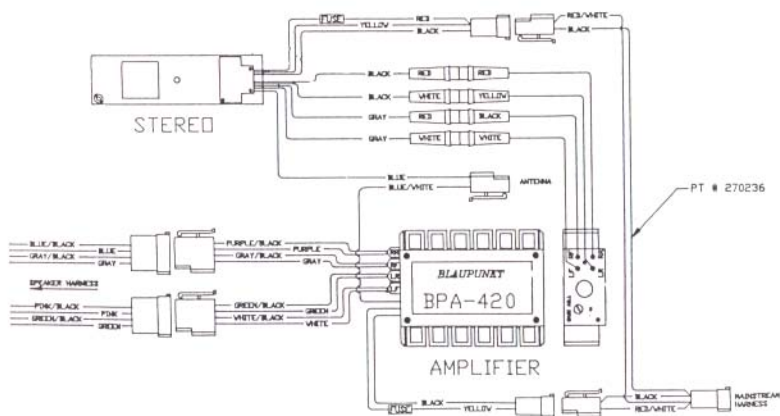

### Amplifier Wiring Procedure



4 PIN HOUSING PT # 410158 (1 REQ'D)  
 TERMINAL PIN SMALL PT # 170040 (3 REQ'D)

DIODE PT# 410051 INSTAL. USING  
 14 GA FM SPADE (2 EA.)  
 PORT MOTOR ONLY

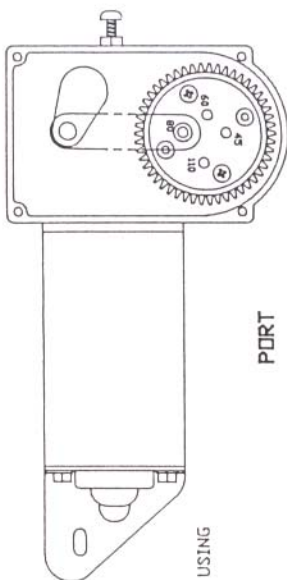
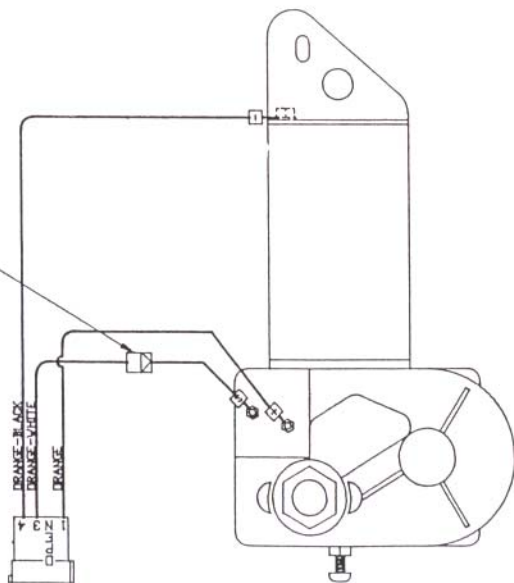

PORT

TO CHANGE MOTOR FROM PORT TO STBD, REMOVE CHROME  
 GEAR PLATE AND ROTATE 180°. LEVER SHOULD REMAIN  
 IN HOLE MARKED 80.

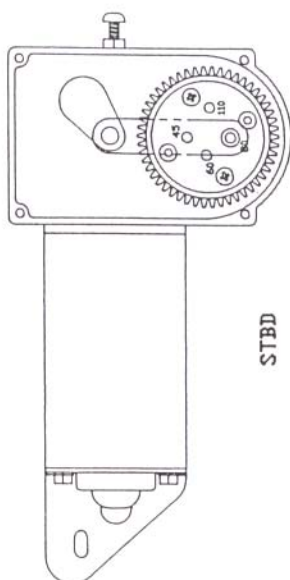

STBD

### Wiper Motor Wiring Diagram

**VII. Warranty Procedure and Owner Responsibility**

1. *The Cobalt Warranty* . . . . .80
2. *Owner Responsibility* . . . . .81

## VII. WARRANTY PROCEDURE AND OWNER RESPONSIBILITY

### 1. Cobalt Warranty

Cobalt Boats warrants the hull and deck of each new Cobalt boat to be free from structural defects in material and workmanship under normal recommended use for a period of five (5) years from the date of delivery to the original retail purchaser.

Cobalt Boats warrants all component parts, other than the hull and deck, of each new Cobalt boat to be free from structural defects in material and workmanship under normal recommended use for a period of two (2) years from the date of delivery to the original retail purchaser.

This warranty does not apply to (1) engines, boat drives, controls, batteries, or other equipment or accessories manufactured by manufacturers other than Cobalt Boats, which are separately warranted by such other manufacturers (appropriate adjustments therefore being provided by their respective manufacturers); (2) installation of engines or accessories installed by others; (3) windshield leakage, upholstery damage, carpet damage and gelcoat damage; (4) the blistering of gelcoat finishes; and (5) any Cobalt boat which has been altered, subjected to misuse, negligence or accident, or used for racing or commercial purposes.

The rights and benefits granted under this warranty to the original retail purchaser of a new Cobalt boat shall extend to any owner of such Cobalt boat during the applicable warranty period, commencing with the date of delivery to the original retail purchaser, as set forth herein, provided this warranty is validated by such owner, as set forth herein. In no event shall the owner of any Cobalt boat, covered by this warranty, have any rights or benefits under this warranty which are greater than the rights and benefits which would have been available under this warranty to the original retail purchaser of such Cobalt boat had the original retail purchaser remained the owner of such Cobalt boat.

Cobalt Boats shall not be liable for special or consequential damages, such as, but not limited to, damages for cost of replacement goods, or damages for claims of third parties against the purchaser, or damages for loss of profits.

To validate this warranty, the original retail purchaser must return the warranty registration card to Cobalt Boats within ten (10) days after purchase of any new Cobalt boat covered by this warranty, and any subsequent owner of a Cobalt boat during the applicable warranty period must give written notice of acquisition of a Cobalt boat to Cobalt Boats within ten (10) days after such purchase.

Notification of any warranty claim, arising within the applicable warranty period, as set forth above, must be made in writing by the owner of the Cobalt boat or by an authorized Cobalt Boats dealer to Cobalt Boats within thirty (30) days after the discovery of the alleged basis for any warranty claim.

During the applicable warranty period, as set forth above, warranty repairs shall be made without charge by Cobalt Boats at its plant in Neodesha, Kansas, or, at the option of Cobalt Boats, by an authorized Cobalt Boats dealer. All warranty repairs shall be subject to the authorization of factory-trained personnel of Cobalt Boats, whose decision will be final. Transportation to and from the Cobalt Boats plant in Neodesha, Kansas, and/or to and from an authorized Cobalt Boats dealer, for warranty repairs, shall be at the owner's expense.

In no event shall the liability of Cobalt Boats under this warranty exceed the purchase price of the specific item or items to which such warranty relates.

This warranty constitutes the only express warranty covering a new Cobalt boat. Any implied warranty, which may be determined to pertain to any component of a new Cobalt boat, is limited to five (5) years on the hull and deck, and limited to two (2) years on all other component parts covered by the express warranty, as set forth above, except in those states which have other limitations on the duration of an implied warranty.

This warranty gives you specific rights and remedies. In addition, you may also have other rights and remedies which vary from state to state.

## **2. Owner Responsibility/Warranty Procedure**

- a.** Before operating your new Cobalt, it is necessary you read and understand this manual. Also, take the time to read the other manuals supplied to you by your dealer.

### **b. Warranty Service Requirements**

1. All Cobalt warranty service must be completed by an authorized Cobalt dealer. If you are not able to return

your boat to your selling dealership, you must contact him so he may assist you in coordinating the warranty repairs. Any claims against Cobalt Boats without prior approval from Cobalt Boats on repairs completed by a non-authorized dealership may be denied.

**c. 20-Hour Check**

1. As per your engine owner's manual, it is necessary to have the first service completed on your new Cobalt at 20 engine hours. There are many checks to be completed on the engine/drive system and your dealer can explain in detail these procedures.
2. Although the engine manufacturer does not require an engine alignment check at the 20-hour check, Cobalt warranty does require this step.
3. Make sure, regardless of who performs the 20-hour check, the drive unit is removed and engine alignment checked and corrected, if necessary. A small amount of adjustment, at this time, is normal. Please consult your selling dealer for further information.

**d. Extended Powertrain Warranty**

Your Cobalt warranty includes an Extended Limited Powertrain Warranty. Your dealer submitted the necessary forms to implement this warranty. Please read the contract supplied to you by your dealer.

It is important you have your Cobalt serviced per the engine manufacturer's recommended instructions. You **must** keep, in your possession, records of all service performed should the extended powertrain warranty be needed. This is to prove the required maintenance has been performed.

If you have any questions referencing your Extended Powertrain Warranty, please contact your Cobalt dealer.

**e. If you sell your Cobalt - - -**

Your warranties are transferable. If you sell your Cobalt to anyone other than an authorized Cobalt dealer, please call Cobalt Boats for the appropriate warranty transfer information (316-325-2653). If the proper transfer procedures are not followed, future warranty may be denied.

**VIII. Service Record Pages** ..... 84







## SERVICE RECORD

Date	Hour Reading	Service Performed



## NOTES



## NOTES



## NOTES





**COBALT BOATS**

1101 Illinois P.O. Box 29, Neodesha, KS 66757