

OWNER'S MANUAL

A29 • R30 • R33 • R33 SURF • R33 OUTBOARD • R35 • R35 OUTBOARD





WELCOME

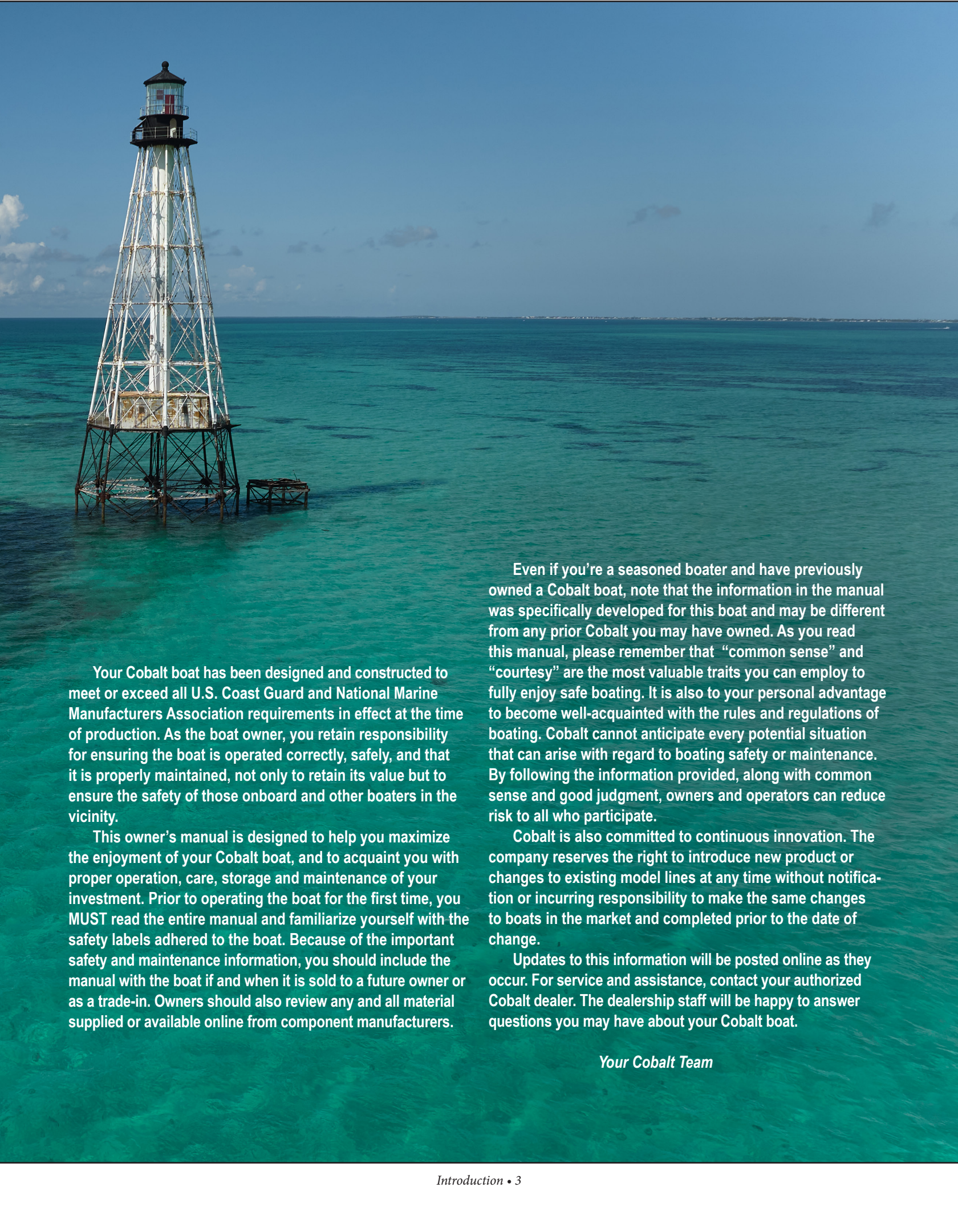

Your Cobalt boat has been designed and constructed to meet or exceed all U.S. Coast Guard and National Marine Manufacturers Association requirements in effect at the time of production. As the boat owner, you retain responsibility for ensuring the boat is operated correctly, safely, and that it is properly maintained, not only to retain its value but to ensure the safety of those onboard and other boaters in the vicinity.

This owner's manual is designed to help you maximize the enjoyment of your Cobalt boat, and to acquaint you with proper operation, care, storage and maintenance of your investment. Prior to operating the boat for the first time, you **MUST** read the entire manual and familiarize yourself with the safety labels adhered to the boat. Because of the important safety and maintenance information, you should include the manual with the boat if and when it is sold to a future owner or as a trade-in. Owners should also review any and all material supplied or available online from component manufacturers.

Even if you're a seasoned boater and have previously owned a Cobalt boat, note that the information in the manual was specifically developed for this boat and may be different from any prior Cobalt you may have owned. As you read this manual, please remember that "common sense" and "courtesy" are the most valuable traits you can employ to fully enjoy safe boating. It is also to your personal advantage to become well-acquainted with the rules and regulations of boating. Cobalt cannot anticipate every potential situation that can arise with regard to boating safety or maintenance. By following the information provided, along with common sense and good judgment, owners and operators can reduce risk to all who participate.

Cobalt is also committed to continuous innovation. The company reserves the right to introduce new product or changes to existing model lines at any time without notification or incurring responsibility to make the same changes to boats in the market and completed prior to the date of change.

Updates to this information will be posted online as they occur. For service and assistance, contact your authorized Cobalt dealer. The dealership staff will be happy to answer questions you may have about your Cobalt boat.

Your Cobalt Team



TABLE OF CONTENTS

Introduction	6	Getting Underway	109
Owner Responsibility/Warranty Procedure	7	Operating Information	110
Certifications.....	7	Precautions	110
Features/Construction	7	Launching.....	112
Publications.....	8	Boarding.....	112
Nautical Terms.....	8		
Symbols.....	10	Care and Maintenance	115
Safety and Responsibilities	11	On-Going Care	116
Owner Responsibility and Boating Education	16	Corrosion Protection	117
General Boating Safety Topics	23	Vinyl Interior and Upholstery	118
On-Product Warning Labels.....	30	Scheduled Maintenance and Service	130
Basic Rules of the Road.....	32	Storage and Winterization.....	135
Watersports Safety.....	36		
Emergency Procedures	41	Warranty Statements	137
Specifications	45	Cobalt Certificate of Limited Warranty.....	138
A29	46	Addendum A—Service Assist Service	
R30.....	48	Agreement	139
R33.....	50	California Evaporative Emissions Control	
R33 Outboard	52	System Warranty Statement	140
R35.....	54		
R35 Outboard	56	Troubleshooting, Logs and Index	141
Components and Systems	59	Troubleshooting.....	142
Routing	60	Warranty Transfer—Boat	145
Fire Suppression Equipment	62	Boat Information	146
Electrical System.....	63	Float Plan.....	147
Fuel System.....	70	Service Log	148
Freshwater System	72	Index	150
Helm and Instrumentation	73		
Basic Function Features.....	81		
On and Under the Water	84		
Performance Boosts	87		
Comfort and Enhancements.....	89		
Arches, Splash & Stow, Canvas and Covers	102		

INTRODUCTION

This owner's manual contains information that is necessary to run the boat properly, as well as safety topics, operation and maintenance requirements.

Even if everything has been planned and designed for the safety of the boat and its users, boating is highly dependent on the weather conditions, the state of the boating water, and the experience and physical condition of the crew. Because of multiple factors, it is impossible to guarantee absolute safety. It is your responsibility as the owner or user to know the boat's equipment, its capabilities, and the boat's intended use.

The specific information on the operation of the equipment and systems with which the boat is supplied or fitted should be supplied by that manufacturer. Read, understand and keep all the information supplied in a clean, as dry as possible, location for ready access and referral as needed. Familiarize yourself and all users with the boat's components before putting the boat into use.

All persons should wear a suitable life preserver/personal flotation device when onboard. In some countries, states, or locales, it is a legal requirement to wear a suitable life preserver/personal flotation device at all times that complies with the regulations and laws.

WARNING

Children, disabled people and non-swimmers should wear a personal flotation device at all times. Children and non-swimmers need special instruction in the use of life preservers/personal flotation devices. Inform all passengers on the proper use of these devices and of the location of all safety equipment, man-overboard recovery equipment, and the location and deployment of any ladder.

WARNING

Avoid contact with any running machinery or moving parts, such as an engine, generator or propeller. Contact can result in, but is not limited to, loss of body parts, strangulation, burns and/or severe loss of blood. Keep all machinery guards in place when machinery is in operation.



Craft Design Category

(Note: Significant Wave Height is the mean height of the highest one-third of the waves, which approximately corresponds to the wave height estimated by an experienced observer. Some waves can be double or more than this height.)

OCEAN—Category A

Craft designed to operate in winds that may exceed wind Beaufort force 8 and in significant wave heights of

13'1.44" (4 meters) and above, and is largely self-sufficient. Abnormal conditions such as hurricanes are excluded. Such conditions may be encountered on extended voyages—for example, across oceans, or inshore when unsheltered from the wind and waves for several hundred nautical miles.

OFFSHORE—Category B

Craft designed to operate in winds up to Beaufort force 8 and associated wave heights and in significant wave heights of 13'1.44" (4 meters). Such conditions may be encountered on offshore voyages of sufficient length, or on coastal waters when unsheltered from the wind and waves for several dozen nautical miles. These conditions may also be experienced on inland seas of sufficient size for the wave height to be generated.

INSHORE—Category C

Craft designed to operate in winds up to Beaufort force 6 and associated wave heights and significant wave heights up to 6'6.7" (2 meters). Such conditions may be encountered in exposed inland waters, in estuaries and in coastal waters in moderate weather conditions.

SHELTERED WATERS—Category D

Craft designed to operate in winds up to Beaufort force 4 and associated wave heights (occasional maximum waves of 1'7.7" [0.5 meters] height). Such conditions may be encountered in sheltered inland waters, and in coastal waters in fine weather.



OWNER RESPONSIBILITY/WARRANTY PROCEDURE

Before Operating

Before operating a Cobalt boat for the first time, it is necessary for all potential operators to read and understand this manual. Also, read all other component manuals and information supplied in the owner's packet.



Warranty Services Requirements

All Cobalt warranty service must be completed by an authorized Cobalt dealer. If the boat cannot be returned to the selling dealership, contact the selling dealership for assistance in coordinating the warranty repairs. Any claims

concerning a Cobalt Boat without prior approval from Cobalt Boats for repairs completed by an unauthorized dealership, repair service, or individual may be denied.



If the Boat is Sold

The warranties may be transferable. If the boat is sold to anyone other than an authorized Cobalt dealer, refer to the Warranty Transfer Form near the end of this manual. If the proper transfer procedures are not followed, future warranty claims may be denied.

CERTIFICATIONS

NMMA

Cobalt Boats is a member of the National Marine Manufacturers Association (NMMA). This independent organization's members include boat, engine and marine equipment manufacturers focused on the improvement and safety of boating.

Cobalt Boats are NMMA-certified. An NMMA certification not only satisfies the U.S. Coast Guard (USCG) regulations but also the more rigorous equipment and system standards based on those established by the American Boat and Yacht Council, Inc. (ABYC). Cobalt boats meet or exceed NMMA safety-based certifications.

Cobalt Boats has made a significant contribution to the boating industry by successfully completing the Mercury MerCruiser® propulsion-installation quality certification program and the Volvo Penta Certified OEM Program.

MerCruiser

The MerCruiser Program partners boat builders with MerCruiser to improve product quality and enhance boating enthusiast satisfaction. The certification program is designed to review all facets of manufacturing and installation processes and to identify opportunities to implement Lean Six Sigma processes and training programs. Key areas of focus include assembly and component specifications, propulsion-installation processes and industry-standard end-of-line test procedures.



Volvo Penta

The Volvo Penta Program requires the boat builder commitment to follow the established training requirements, installation procedures and documentation processes throughout the engine installation and testing process. Ultimately, the goal of the program is to improve integrated product quality and customer satisfaction, as well as to reduce warranty repairs and costs.

FEATURES/CONSTRUCTION

Amenities

Cobalt boats incorporate classic styling with the clean lines that have defined Cobalt design for over 40 years. Performance features include hand-laid, reinforced Kevlar with an all-fiberglass stringer system and AME 1000 vinyl-ester resins used on the deck and hull for superior strength, toughness and weight savings.



Construction Standards/Certifications

A Limited Warranty Statement explaining terms and conditions appears elsewhere in this owner's manual. Familiarize yourself with the contents, requirements and limitations as described in the Statement. Failure to follow the operating instructions and proper maintenance requirements as outlined within this owner's manual may void the warranty.

Construction standards detailing industry standards followed in building Cobalt Boats are explained within this manual. Contact an authorized Cobalt dealer for any additional information regarding construction information.



Serial Number Locations

All Cobalt boats, the engine and propulsion units, and various other components onboard are marked with unique serial numbers. It is good practice to prepare a list of all

serial numbers and store the list securely away from the boat. A page is supplied at the end of this owner's manual for that purpose.

The Hull Identification Number (HIN) is located on the upper starboard side of the transom. For the locations of other serial numbers, refer to the equipment operator's manuals supplied in the owner's packet.

PUBLICATIONS

The owner's packet includes information about onboard systems and equipment furnished by suppliers whose components are used on Cobalt boats. Refer to these manufac-

turer's manuals for additional operation and maintenance instructions not covered in this owner's manual.

NAUTICAL TERMS

The following terminology is provided to assist boats in understanding marine lingo:

ABOARD—On or in the boat.

ABYC—American Boat and Yacht Council, Inc.

AFLOAT—On the water.

AFT—Toward the rear or stern of the boat.

AGROUND—Touching bottom.

AMIDSHIP—Center or middle of the boat.

ANCHOR—(1) A casting shaped to grip the lake bottom to hold the boat in place. (2) The act of setting the anchor.

ASHORE—On the shore.

ASTERN—Toward the stern or back of the boat.

BAIL—To remove water from the boat with a pump, bucket, sponge or other aid.

BEAM—The widest measurement of the boat.

BEARING—Relative position or direction of an object from the boat.

BILGE—The lowest interior section of the boat hull.

BOARDING—To enter the boat.

BOUNDARY WATERS—A body of water between two areas of jurisdiction: i.e., a river between two states.

BOW—The front of the boat.

BULKHEAD—Vertical partition (wall) in a boat.

BUNKS—Carpeted trail hull supports.

BURDENED BOAT—Term for the boat that must "give-way" to boats in right-of-way.

CAPACITY PLATE—A plate that provides maximum weight capacity and engine horsepower rating information. It is located in full view of the helm.

CAPSIZE—To turn over.

CAST-OFF—To unfasten mooring lines in preparation for departure.

CENTER LINE—A lengthwise imaginary line which runs fore and aft of the boat's keel.

CHINE—The point on a boat where the side intersects (meets) the bottom.

CLEAT—A deck fitting with ears to which lines are fastened.

CONSOLE—Also called the helm. The steering wheel area of the boat.

CRANKING BATTERY—The main battery used for engine starting and electrical circuits.

CURRENT—Water moving in a horizontal direction.

DECK—The horizontal structure that forms the "roof" of the hull, strengthening it and serving as the primary working surface.

DEEP CYCLE BATTERIES—Special long-running batteries which can be repeatedly discharged and recharged without significant loss of power.

DOLLY WHEEL—A rolling jack assembly at the front of the towing trailer used for positioning the coupler during trailer hookup.

DRAFT—the depth of the boat below the water line, measured vertically to the lowest part of the hull.

ELECTROLYSIS—The break-up of metals due to the effects of galvanic corrosion.

EPIRB—Emergency Position Indicating Radio Beacon.

FATHOM—Unit of depth or measure; 1 fathom equals 6 feet.

FENDERS—Objects placed alongside the boat for cushioning and protection of the boat's finishes. Sometimes called bumpers.

FORE—Toward the front or bow of the boat. Opposite of aft.

FREEBOARD—The distance from the water to the gunwale.

FUEL SENDING UNIT—The electrical device that is mounted to the fuel tank and controls the dashboard fuel gauge.



GIVE-WAY BOAT—(1) Term for the boat that must take whatever action necessary to keep well clear of the boat with the right-of-way in meeting or crossing situations.
(2) The burdened boat.

GUNWALE—The rail or upper edge of a boat's side.

HEAD—A marine toilet.

HELM—The steering wheel or command area.

HULL—The body of the boat.

HYPOTHERMIA—A physical condition where the body loses heat faster than it can produce it.

IN-LINE FUSE—A type of protective fuse located in the power wire of a direct current (DC) circuit, usually near the battery.

KEEL—The lowest portion of the boat; extends fore and aft along the boat's bottom.

LIST—Leaning or tilt of a boat toward the side.

LOA—Length overall.

MAKING WAY—Making progress through the water.

MARINE CHART—Seagoing maps showing depths, buoys, navigation aids, etc.

MOORING—An anchor, chair, or similar device that holds a boat in one location.

NAVIGATION AID—Recognizable objects on land or sea such as buoys, towers or lights which are used to fix position to identify safe and unsafe waters.

NMMA—National Marine Manufacturers Association.

NO-WAKE SPEED—The speed at which a boat travels to produce an imperceptible wake.

PFD—Personal flotation device.

PITOT TUBE—See *SPEEDOMETER PICKUP TUBE*.

PLANING HULL—A hull designed to lift, thereby reducing friction and increasing efficiency.

PORPOISE—A condition in which the bow bounces up and down, caused by trimming the engine too far out.

PORT—(1) The left side of a boat when facing the bow.

(2) a destination or harbor.

PRIVILEGED BOAT—Term used for the boat with the right-of-way.

RIGHT-OF-WAY—Term for the boat that has priority in meeting or crossing situations. The stand on or privileged boat.

RULES OF THE ROAD—Regulations for preventing collisions on the water.

SPEEDOMETER PICKUP TUBE—Also called the pitot tube. The plastic device that extends below the bottom of the boat. It connects to the speedometer with flexible plastic tubing.

STAND-ON BOAT—Term for the boat that must maintain course and speed in meeting or cross situations. The privileged boat.

STARBOARD—The right side of the boat when looking toward the bow.

STERN—The back of the boat.

STOW—To pack the cargo.

SURGE BRAKES—A type of trailer braking system designed to automatically actuate when the tow vehicle's brakes are applied.

TRANSDUCER—The unit that send/receives signals for the depth sounder.

TRANSOM—The transverse beam across the stern.

TRIM—Fore to aft and side to side balance on the boat when loaded.

UNDERWAY—Boat in motion, i.e., not moored or anchored.

USCG—United States Coast Guard.

VISUAL DISTRESS SIGNAL—A device used to signal the need for assistance such as flags, lights and flares.

WAKE—The waves that a boat leaves behind when moving through the water.

WATERWAY—A navigable body of water.

WINDLASS—An electric winch to raise the anchor.

SYMBOLS

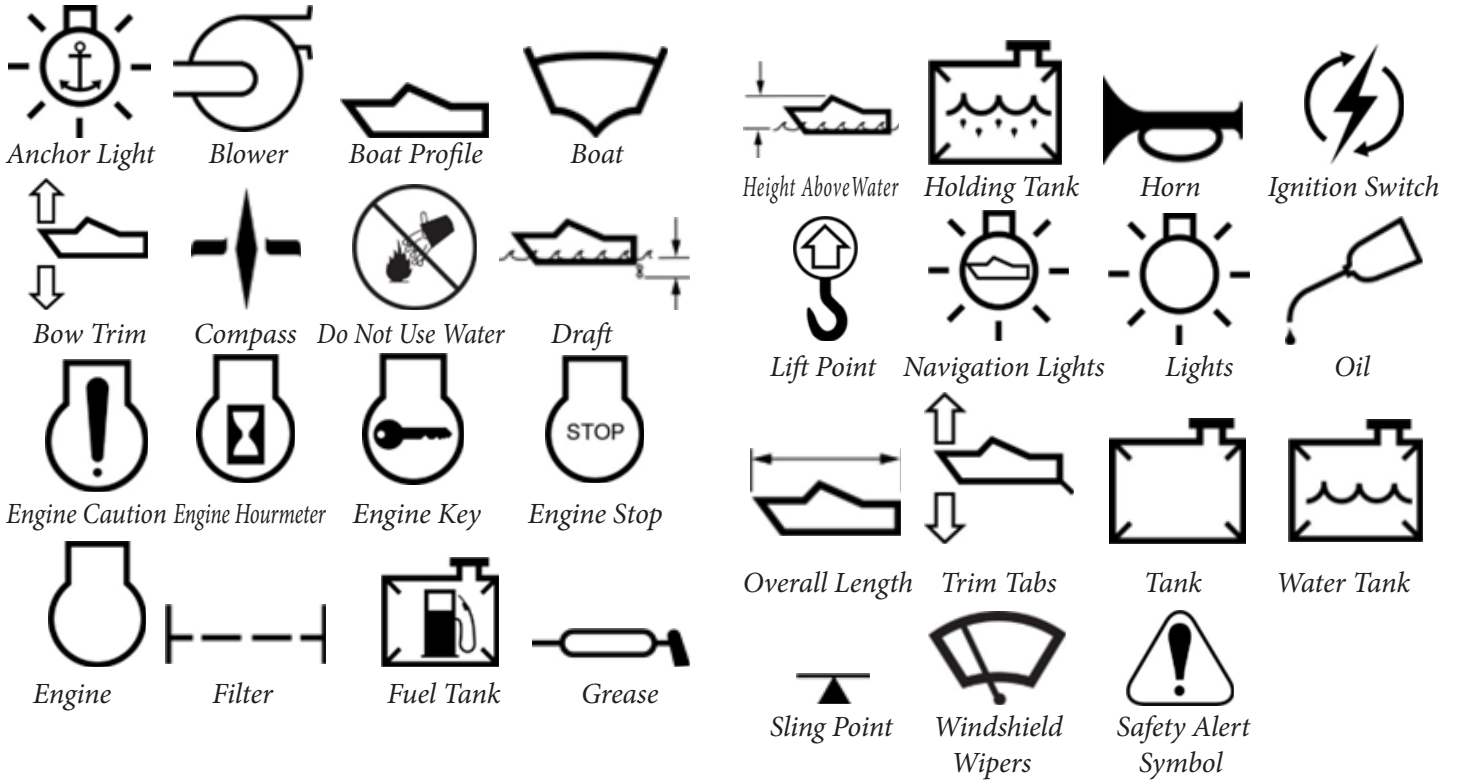

Safety and Responsibilities



EMBRACING SAFETY

Your safety, the safety of your passengers, and other boaters are among your responsibilities as operator of the boat. The boat must be in compliance with U.S. Coast Guard (USCG) safety equipment regulations. It is important for all boat operators including those who do not own the boat, to know how to react correctly to adverse weather conditions, have good navigation skills, and follow the “Rules of the Road” as defined by the USCG, as well as state, county, and local regulations.



Prior to Operation

At the time of delivery, the owner/operator is responsible for:

- Understanding warranty terms and conditions of both the propulsion unit(s) and boat.
- Obtaining insurance.
- Examining the boat to ensure proper operation of all systems.

Before operating the boat, the owner/ operator is responsible for:

- Obtaining state registration of the boat.
- Providing the proper USCG-required safety equipment.
- Following the proper break-in procedure for the propulsion unit(s).
- Understanding the safety information and proper operating procedures as presented within this owner’s manual.

While operating the boat, the owner/operator is responsible for:

- Knowing that all safety equipment and personal flotation devices are in good condition and suitable for your boat and passenger load.
- Having at least one other passenger who is capable of handling the boat in an emergency.
- Following safe operating practices and the nautical Rules of the Road.
- Understanding proper maintenance and knowledge of the boat’s operating systems.
- Providing safety training for the passengers.
- Avoiding use of alcohol and other drugs.
- Providing assistance to other boaters.

More information on all of these topics follows.



Signal Words and Symbols Used in this Manual

Throughout this manual specific precautions and symbols identify safety-related information. You will find **DANGER**, **CAUTION**, **WARNING**, and **NOTICE** symbols which require special attention. **Please read them carefully and follow these precautions as indicated!** They will explain how to avoid hazards that may endanger you, your passengers, towed participants, and other boaters. **PLEASE REVIEW ALL SAFETY INFORMATION.**



DANGER indicates a hazardous situation which, if not avoided, will result in death or serious injury.



WARNING indicates a hazardous situation which, if not avoided, could result in death or serious injury.



CAUTION indicates a hazardous situation which, if not avoided, could result in minor or moderate injury.



NOTICE is used to address practices not related to physical injury.



Basic Safety Rules

Make sure you understand all of the operating instructions prior to attempting to operate this boat.

Boating-related accidents are generally caused by the operator’s failure to follow basic safety rules or written precautions. Most accidents can be avoided if the operator is completely familiar with the boat and its operation, follows recommended practices, and is able to recognize and avoid potentially hazardous situations.

*Past accident data shows that most **fatalities** involve actions which cause falls or ejections overboard, mishaps with towed persons, propeller strikes, collisions, and carbon monoxide exposure. Past accident data shows that most **injuries** are associated with collisions, mishaps with towed persons, falls or ejections overboard, being struck by the propeller, and fires and explosions. These incidents are mostly caused by operator inattention, operator inexperience, reckless operation, alcohol/drug use, excessive speed, passenger or towed person behavior, and violation of navigation rules.*

Failure to observe the safety recommendations contained in this manual may result in severe personal injury or death to you or to others. Use caution and common sense when operating your boat. Don't take unnecessary chances! Basic safety rules are outlined in this section of the manual.



Pre-operation Check List— Before Leaving the Dock



WARNING

Failure to follow these precautions may result in severe injury or death to you and/or others.

The operator shall:

- Check that weather conditions are safe for boating. It is the driver's responsibility to determine if weather or other factors have created an unsafe boating environment. Boaters must continuously be aware of weather conditions. Sudden storms, wind, water conditions, lightning, etc., can unexpectedly put boaters in grave danger. Always check the local weather report before going boating.
- Check that drain plugs are securely in place.
- Check bilge pump, horn, lights, blower and other equipment to verify they are operating properly.
- Verify that the emergency cutoff switch lanyard is in proper operating condition and is properly affixed to the driver.
- Check the operation of the steering system. Verify that the steering is operational before launching the boat. If the boat is already in the water, verify proper steering wheel operation at low speed. Turn the steering wheel full stop in both directions and verify proper rudder movement. Ensure that there is no binding or stiffness in the steering wheel rotation. Binding and stiffness are an indication that the steering needs repair. Failure of the steering cable will result in loss of control of the boat.
- Ensure that the load of persons, ballast, and equipment is within the limits stated on the USCG Maximum Capacities Plate and all are properly distributed, based on instructions in this manual.
- Check that all safety equipment and life jackets, personal flotation devices (PFDs), and throwable cushions are in good condition and suitable for your boat and passenger load.
- Inform all passengers where safety equipment is located and how to use it.
- Have at least one other passenger who is capable of operating the boat safely in case of an emergency.



DANGER

GASOLINE VAPORS CAN EXPLODE. BEFORE STARTING ENGINE, OPERATE THE BLOWER FOR FOUR (4) MINUTES, AND CHECK THE ENGINE COMPARTMENT BILGE FOR GASOLINE VAPORS.

- It is very important to open the engine cover, where equipped, and check the engine compartment and bilge for liquid gasoline and gasoline vapors prior to each use of your boat and after refueling. Failure to do so may result in fire or explosion as well as serious injury or death to you and/or others.
- If you see liquid gasoline in the engine compartment/bilge or smell gasoline vapors, **DO NOT** attempt to start the engine. Liquid gasoline in the bilge is an extreme fire and explosion hazard which may cause injury or death. Find and fix the source of the leakage; remove the liquid gasoline from the bilge. Then ventilate the engine compartment/bilge and run the blower to remove all gasoline vapors before starting the engine.
- If gasoline vapors persist after running the blower, **DO NOT** attempt to start the engine. Likely, there is a gasoline leak that is creating the excessive vapor.
- Always operate the blower below cruising speed and after stopping the boat.



Precautions While Underway



DANGER

Failure to follow these precautions will result in serious injury or death.

The operator shall:

- Check that the area behind the boat is all clear before starting the engine(s) to **AVOID PROPELLER INJURY** to persons in the water behind the boat or on the swim platform.
- Turn off the engine(s) prior to anyone occupying the swim platform or being in the water behind the boat to **AVOID PROPELLER INJURY**. Being in neutral gear is insufficient; the propeller may still be turning, or the engine(s) may be inadvertently shifted into gear.
- Not back the boat toward persons in the water behind the boat to **AVOID PROPELLER INJURY**.
- Not allow people to be on or near the swim platform, where equipped, or in the water near the swim platform while the engine(s) is running because **CARBON MONOXIDE** will exist around the back of the boat when the engine(s) is running. Engine exhaust contains carbon monoxide, which is a deadly, odorless, colorless gas.

- Not operate the engine(s) in a confined space or while tethered to another vessel as **CARBON MONOXIDE** will be around the boats.
- Not go under the boat cover with the engine(s) running or shortly after the engine(s) has been running because **CARBON MONOXIDE** may remain under the cover. Remove cover to ventilate the area.
- Follow safe operating practices, the “Rules of the Road,” and the Watersports Responsibility Code.
- Not operate a boat if under the influence of alcohol or other drugs.
- Attach the emergency cutoff switch lanyard to the boat operator when operating the boat.
- Maintain a proper course and safe speed at all times to avoid collisions.
- Maintain a lookout for other boats, swimmers, and obstructions in the water.
- Operate slowly in congested areas such as marinas and mooring areas.
- Keep a safe distance from other boats, swimmers, personal watercraft, docks, and fixed objects.
- Look before you turn/maneuver the boat so as to avoid potential collisions with oncoming or overtaking vessels.
- Be aware that this boat is a high-performance boat and is capable of quick, tight turns and changes in direction. Familiarize yourself with the handling characteristics of the boat. It is the operator’s responsibility to operate the boat in a manner that ensures the safety of all passengers. Abrupt maneuvers may result in the ejection of unsecured, unseated, or improperly positioned passengers. Verbally warn passengers before making quick, tight turns so they may have time to grasp a handrail, handhold, or portion of the boat.
- Be aware that your boat will handle differently, depending on loading and on-board weight distribution.
- Ensure that all passengers are properly and securely seated in appropriate seating locations to avoid falling or falling overboard.
- Instruct and ensure that passengers remain properly seated at all times while the boat is in motion above idle speed.
- Not allow passengers to sit on the transom, seat backs, engine cover or sides of the boat while the engine(s) is



- running, and the boat is in motion, to avoid falling overboard.
- Not allow passengers to sit in a position that obstructs the operator’s view.
- **NEVER** leave children unattended and in the boat without adult supervision.
- Have children riding in the bow of the boat be accompanied by an adult in the bow and ensure that all remain seated when the boat is in motion.
- Not let passengers occupy seats which may be in the path of the tow line.
- Slow down when crossing waves or wakes in order to minimize the impact on passengers and the boat. Crossing waves or wakes at an angle (such as 45 degrees) rather than perpendicularly will reduce the severity of the impact. Avoid rough water, large waves and large wakes from other boats when at high speed. Jumping waves/wakes or slamming the bow will cause large vertical impacts which may cause injury to occupants or cause ejections.
- For safe towing (water skiing, tubing, wakeboarding, wake surfing, knee boarding, etc.) be experienced and have an observer (an observer or “spotter” is required by law in most states). A rear-view mirror is helpful if you are allowed to tow without an observer in your state.
- Avoid letting tow lines or mooring lines wrap around anyone’s body parts/limbs. Doing so could allow body parts/limbs to become entangled in the line and could cause significant injury, such as amputations.
- Keep track of tow lines and dock lines so that they do not become entangled in the propeller. A tow line will wrap quickly around a spinning propeller and is capable

of immobilizing the boat and dragging a person entangled in the tow line underwater or causing amputations. Shut off the engine(s) if a tow line has potential for wrapping in the propeller.

- The tower is designed to pull a single individual. Please consult the remainder of this manual and/or warning labels on the tower for details. **DO NOT** climb, sit on, stand on, or jump/dive off of the tower. The tow line may loop on inverted tricks. **DO NOT** sit behind the pulling point of the tower.
- **NEVER** allow any type of spark or open flame on board. It may result in fire or explosion.
- Avoid grounding the boat: Be familiar with local conditions and water depth. If you are uncertain, then proceed slowly with caution. Sudden groundings from planing speeds may cause rapid decelerations and cause occupants to impact the boat and/or to be ejected from the boat. Boat damage may also occur.
- Always watch for low obstacles such as tree limbs, bridges or power lines, especially in boats with tow towers.
- Seek shelter from open water if there is threat of lightning or severe weather.
- **NEVER** dive from the boat without being absolutely sure of the depth of the water. Severe injury or death may occur from striking the bottom or submerged objects. Striking the bottom or a submerged object while diving headfirst can cause paralysis, head injury or death.
- Provide assistance to other boaters in distress while ensuring the safety of your own passengers.
- When you leave the boat, take the keys with you. This will keep untrained and unauthorized persons from operating the boat. (This will not be applicable on some keyless ignition systems.)



Safety While Maintaining the Vessel

WARNING

Failure to follow these precautions may result in severe injury or death to you and/or others.

The operator shall:

- Visually inspect the engine compartment, where equipped, and ventilate after refueling.
- Inspect the fuel system regularly. Examine fuel tanks, hoses and fittings for leaks or corrosion at least annually because leaking fuel is a fire and explosion hazard.

- Never remove or modify components of the fuel system in any way except for maintenance by qualified personnel. Tampering with fuel components may cause a hazardous condition which could lead to a fire or explosion.
- Never override or modify the engine neutral starting safety switch in any way. Your boat engine(s) should not start in gear. If it does, do not use the boat until this safety feature is fixed by an authorized dealer.
- Be aware that batteries generate small amounts of dangerous hydrogen gas when charging. This gas is highly explosive. Keep all sparks, flames and smoking well away from the area. Failure to follow instructions when charging a battery may cause an explosion of the battery or the atmosphere near the battery, which could result in death or serious injury.
- Keep the engine(s) off whenever the engine box/cover/hatch, if equipped, is open. The engine box/cover/hatch serves as a machinery guard. Clothing or body parts can get caught in moving parts, causing death or serious injury. Keep away from moving parts.
- Not replace your boat's marine parts with automotive parts or parts that were not designed for your boat.
- Be aware that battery electrolyte fluid is dangerous. It contains sulfuric acid, which is poisonous, corrosive and caustic. If electrolyte fluid is spilled or placed on any part of the human body, immediately flush the area with large amounts of clean water and immediately seek medical attention.
- Check the tightness of the tower bolts **BEFORE** each use. If a tower collapses, it may result in injury to boat occupants or towed persons.
- Not modify the tow bar. The tow pylon/bar is not designed for vertical extensions. Any modifications to the tow pylon/bar or its mountings may result in damage to the boat and injury to the user.
- Only lift the boat from approved lift points, which are identified in later parts of this owner's manual.



OWNER RESPONSIBILITY AND BOATING EDUCATION

Basic Understanding

The following briefly explains many of the systems on-board.

Propulsion System

A propulsion system consists of an engine turning a shaft that transfers power to a propeller. Some boats are equipped with more than one. Mounting may be as outboards, or as stern drive (inboard engine/outboard propeller).

Remote Control System

The shift levers and throttle levers are connected to the engine(s) and propulsion unit(s) by mechanical push/pull cables. The shift lever controls the direction of the boat, and the throttle lever controls the speed of the boat.

Steering System

The steering wheel (helm) is connected to a hydraulic cylinder. As the steering wheel is turned, hydraulic fluid directs movement of a steering cylinder. The cylinder is mechanically connected to the drive units.

Fuel System

The fuel system consists of a permanent tank with an air vent system, fuel level sensor and fuel fill components. The tank has an anti-siphon valve to prevent fuel from accumulating in the bilge if a hose breaks.

Ventilation System

The ventilation system removes fuel fumes by using blowers from the engine compartment (where equipped) and takes in fresh air through vents. Always keep vents free from obstructions.



Operate the blower for at least four (4) minutes each time the engine is started. In addition, the blower should be operated continuously when the boat is stopped, operating at cruising speed or when the generator is running.

Store flammables only in approved, vented containers securely fastened in a locker sealed from the interior of the boat and vented out of the side of the boat. Storing flammables in areas not designed for vapor removal creates a hazard.

Be aware of carbon monoxide from this and other boats. Allow air movement to dissipate the fumes. More information about carbon monoxide follows.

Electrical Systems



Never use an open flame in the battery storage area. The battery will explode if a flame or spark ignites the free hydrogen gas given off during charging. Be sure to prevent sparks near the battery.



Only a qualified marine electrical technician should service the boat's electrical system. Disconnect the electrical system from its power source before performing maintenance. Never work on the electrical system when it is energized. Electrical appliances must not exceed the rated amperage of the boat circuit. Observe the electrical system carefully while it is energized. The only electrical components that can be left unattended are the automatic bilge pump, fire protection and alarm circuits.



Always turn off the engine before servicing the battery. Disconnect the battery cables before working on the electrical system to prevent arcing or damage to the engine's alternator. Disconnect the negative (-) cable first, and then disconnect the positive (+) cable.

Cobalt boats can be equipped with one or two electrical systems. A direct current (DC) system is battery-powered and supplies electricity to lights, pumps, blowers, engine ignition and sometimes a refrigerator. An alternating current (AC) system is shore power or generator and supplies electricity to the electrical outlet, air conditioning, battery charge and other 110V AC or 220V AC appliances or components. **Do not exceed rated amperage of electrical circuits.**

If the boat is equipped with an optional battery charger, it must be plugged in only into a Ground Fault Circuit interrupter (GFCI)-protected AC outlet. When using an extension cord, connect the charger AC plug first before connecting the extension cord to the GFCI outlet.

Make the connection in an open area, free of any explosive fumes. The connections must be secure to avoid contact with any water.

Cooling System

The engine(s) and generator, if equipped, are cooled by the continuous intake of raw water through independent water intakes. The water flows to water pumps on the engine(s) and/or generator for circulation around internal components.

The engine water intakes and outlets are located in the drive units. A generator water intake is at the bottom of the hull and the exhaust is usually on the side of the boat, above the waterline.

If your boat is equipped with an air conditioner, the water intake for it is in the bottom of the hull and exits from the side.

Cobalt boats may be equipped with a self-contained cooling system that pumps a mixture of fresh water and antifreeze through a large heat exchanger to reduce temperatures. Raw water is circulated through the other side of the heat exchanger to dissipate heat absorbed by the coolant mixture.

Exhaust System

The engine and generator exhaust systems, if equipped, remove the gasses produced by the running engine, and vents them away from the boat. Engine exhaust is usually vented through the drive unit propeller but may be diverted through the transom with the optional captain's call exhaust system. Engine and generator cooling water are also removed along with the exhaust gases.

Never change the original exhaust system configuration. Inspect the entire exhaust system for tightness before each use. Leaks permit carbon monoxide exposure.

Some boating areas require the use of a muffler to reduce exhaust sound levels. In these instances, consult with an authorized Cobalt dealer for assistance.

Lubrication System

The engine(s) and generator, if equipped, use a pressurized continuous loop lubrication system that must be periodically serviced in accordance with the manufacturer's recommendations.

The engine(s) has/have electrical transducer units to provide oil pressure signals to gauges at the helm. Full oil pressure must be available for proper lubrication, so monitoring the gauges is important, especially when operating at cruising speeds and above.

Bilge

A drain plug is located in the transom to allow water to drain before trailering and storing. Before every use, inspect the drain plug and bilge pump. Routinely clean the pump strainer, float switch, intake, and area under the pump. It is a violation of federal law to pump overboard the contents of the bilge if such contains oil or fuel.



Always install the drain plug before launching the boat, to prevent the boat from sinking.



Important Safety Information

Your safety, the safety of your passengers, and the safety of other boaters is dependent on how you operate and maintain your boat. As operator or owner of this boat, you are responsible for the safety of those with and around you while boating.



Responsibilities of Boat Owner and Operators

It is the owner's responsibility to ensure that the operator of the boat has been properly instructed in the lawful and safe operation of this vessel. Therefore, before operating the boat, thoroughly read this owner/operator manual. Be sure you understand each item before operating it. Improper operation or trailering of the boat could lead to severe personal injury or death. Improper operation or trailering of the boat may also damage the boat.

The operator and the boat owner assume all risks for themselves, their guests and anyone in proximity to their boat, and ensure that all passengers understand the risks and responsibilities associated with boating.

This manual is not intended to provide complete training on all aspects of boat operation. We strongly recommend that all operators of this boat seek additional training on boat handling and safety. Have all operators become familiar with the handling characteristics, and proper steering and control system usage before attempting high-speed operation.

At the time of delivery, the owner/operator is responsible for:

- Understanding the warranty terms and conditions of your boat, your engine, and your trailer.
- Obtaining insurance.
- Examining the boat to ensure the proper operation of all systems.

Before operating the boat, the owner/ operator is responsible for:

- Registering the boat as required in the jurisdiction where the boat is being operated.
- Providing the proper (USCG) safety equipment, and checking local, state and federal agencies as to laws and regulations (USCG carriage requirements).
- Carefully reading and understanding safety information and proper operating procedures within this manual.
- Obtaining other boating education if you lack operational experience.
- Familiarizing yourself with the navigable waters where you intend to operate the boat.
- Following the proper break-in procedure for the engine(s).

Registration

Federal law requires that all motorboats be registered and that all motorcraft not documented by the U.S. Coast Guard display registration numbers. In nearly all states, this means registration with a designated state agency. In a few jurisdictions, the Coast Guard retains registration authority. Your dealer will either supply registration forms or tell you where they may be obtained. The agency will supply you with a certificate which must be carried with you when the boat is in operation.

International laws may vary as to required registration.



Insurance

The boat owner may be legally responsible for damages or injuries caused by both himself and the operator (if different than the owner). Common sense dictates that you carry adequate personal liability and property damage insurance on your boat, just as you would on your automobile. Many states have laws detailing minimum insurance needs. Your insurance agent or your dealer may be able to supply you with more information. You should also protect your boat from physical damage or theft.



Boating Safety Education Opportunities

It is recommended that the boat owner/operator obtain boater safety education. If you have never owned a boat before, you can get an excellent introduction to boat handling from organizations such as the U.S. Coast Guard, American Red Cross, United States Coast Guard Auxiliary, or your local boating authority. Even if you are a veteran boater, these courses will help sharpen your boating skills as well as bring you up to date on current rules and regulations. See your local boating agency or dealer for information on classes in your area.

Some states require youths, 16 years of age and younger, to complete a boating safety course before operating any watercraft. Many others require operators under the age of 18 to be licensed in small boat operation.

Boat smart from the start: Take a boating safety course

and get a free vessel safety check annually for your boat.

For more information, contact: United States Coast Guard Auxiliary, www.cgaux.org; United States Power Squadrons, 1-888-FOR-USPS, www.usps.org.

The following is a list of some other agencies and organizations that offer Water Safety, First Aid and CPR courses or information. To find boating safety courses in your area, call your state's local boating agency or the USCG boating safety course line at 1-800-336-2628 (1-800-245-2628 in Virginia).

- USCG Office of Boating (www.uscgboating.org)
- American Red Cross (www.redcross.org)
- U.S. Coast Guard Auxiliary (www.cgaux.org)
- U.S. Power Squadrons (www.usps.org)
- State Boating Offices
- Canadian Power and Sail Squadrons (www.cps-ecp.ca)
- Boat Owners Association of the United States (www.boatus.com)
- National Safe Boating Council (www.safeboatingcouncil.org)
- Water Sports Industry Association (www.wsia.net)
- European or international organizations



Operation by Minors and Licensing

If your boat will be operated by a minor, remember to have an adult present at all times. Many states have laws regarding minimum age and licensing requirements for minors.

Some states require boat training courses, certification, or licensing for minors and/or adults. Contact state and local authorities for requirements that apply in your area.

Your boat and equipment must be in compliance with federal, state and local safety equipment regulations. USCG regulations require certain safety equipment be present on your boat during operation. For a detailed description, obtain "Federal Requirements for Recreational Boats" published by the U.S. Coast Guard and available online at:

<http://www.uscgboating.org/images/420.PDF>

In addition to the USCG regulations, other local and/or international law enforcement agencies may have similar requirements. You should check with your local marine law enforcement agency regarding any such requirements before boating.

SAFETY AND REQUIRED EQUIPMENT

Equipment requirements for coastal and inland waters differ. Check with local authorities and/or the USCG for further information about coastal water requirements.

The Federal Boat Safety Act of 1971 (FBSA/71) and the National Recreation Boating Safety Program have established minimum safety standards for boats and associated equipment, specified by the USCG. In addition, the American Boat and Yacht Council (ABYC) and the National Marine Manufacturers Association (NMMA) work with boat builders to develop voluntary standards that exceed the USCG requirements. The included safety equipment on your boat meets or exceeds the standards of the USCG, ABYC and the NMMA.

Some required safety equipment, such as life jackets (PFDs), are not included with your boat purchase. Your dealer can help you choose the appropriate equipment.

NOTICE

Many states' equipment requirements go beyond USCG requirements. Contact your state boating office for further information.



Navigation Lights

Your boat is equipped with navigational lights. Recreational boats are required to display navigational lights between sunset and sunrise and other periods of reduced visibility (fog, rain, haze, etc.). Navigation lights are provided to keep other boats informed of your presence and course. It is up to you to make sure they are operational, displayed correctly, and turned on when required.



Compass

To aid in navigation, Cobalt boats may be equipped with a compass mounted at the helm. Refer to the compass user's manual in the owner's packet for operating informa-

tion. The compass may require calibration. Contact your authorized Cobalt dealer for assistance.



Other Navigation Equipment

Other navigation equipment, such as depth sounder radar, LORAN system or global positioning system, can be installed by an authorized Cobalt dealer. Operation and maintenance of that equipment is provided by the manufacturer.

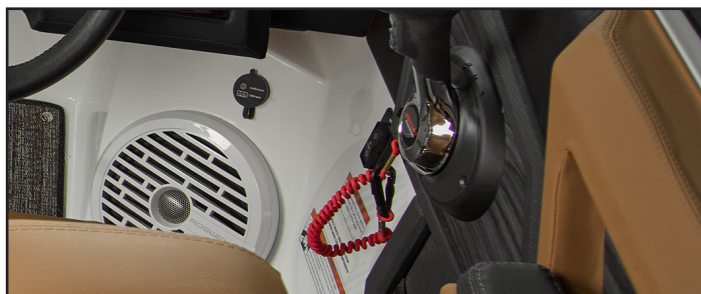

Emergency Safety Stop Switch

Your boat is equipped with an Emergency Safety Lanyard (cutoff switch). We recommend that the lanyard be secured to the operator and the lock plate attached to the emergency cutoff switch prior to starting the engine(s) and anytime the engine(s) is operating. The Emergency Safety Lanyard is designed to turn off the engine(s) whenever the operator moves far enough away from the helm to activate the switch. The purpose is to stop the engine(s), propeller, and boat in the event the operator leaves the helm location, falls overboard, or is ejected from the boat. If the engine(s) is stopped it will prevent the boat from becoming a run-away, unmanned boat, which may cause injury or death to boat occupants who have fallen overboard or been ejected, or to other nearby people. If the engine(s) stops, it will minimize the subsequent opportunity for propeller contact with the operator or other persons in the water. If the engine(s) and boat stop it will afford opportunity for the operator or other persons who have fallen overboard to safely re-board the boat.



It is required by law that you use the Emergency Safety Lanyard system because failure to do so can cause death or serious injury. DO NOT operate the boat if the Emergency Safety Lanyard system does not function properly.

- Attach the Emergency Safety Lanyard to a secure place on your clothing, your arm or your leg while operating.
- **DO NOT** attach the lanyard to clothing that could tear loose.
- **DO NOT** route the lanyard where it could become entangled, preventing it from functioning.
- Avoid accidentally pulling the lanyard during normal operation.
- Loss of engine power means loss of most steering control.
- Without engine power, the boat will decelerate rapidly. This could cause people in the boat to be thrown forward or ejected overboard if they are not properly seated in the boat.

There are practical limitations to what the Emergency Safety Lanyard can do. It can take several seconds for the engine(s) and propeller to stop turning. The boat can continue to coast for several hundred feet depending on the boat speed at the time the switch is activated. While the boat is coasting, it can cause injury to anyone in its path. Accidental loss of power can be hazardous particularly when docking or in heavy seas, strong current, or high winds.

While at the dock or when the boat is not moving, periodically disconnect/pull the Emergency Safety Lanyard out of the switch while the engine is running to test for proper operation. The engine(s) should shut off when the lanyard is disconnected/pulled from the switch. You should not be able to restart the engine(s) until the lanyard is back in place.



Personal Flotation Devices

Federal law requires that you have at least one wearable Personal Flotation Device (PFD) of the proper size (Type I, II, III or V), for each person on board or being towed, and at least one throwable PFD (Type IV) in the boat. PFDs must be Coast Guard-approved, in good and serviceable condition and the appropriate size for the user. To meet requirements, each lifesaving device must have a current,



legible USCG approval stamp permanently affixed. At the beginning of each season, inspect life jackets (PFDs) for damage and test for proper flotation. Refer to the life jacket (PFD) manufacturer's information.

REMEMBER—The best PFD is the one that is worn—that is, the one that can save your life. PFDs are intended to save lives; it is highly recommended that you and your passengers wear them while in the boat. Learn how to use them and adjust as necessary for comfort. It is especially important that children and non-swimmers wear a life jacket (PFD) at all times. Make certain all passengers know where life jackets are located, how to put on and properly adjust their life jackets (PFDs), and that life jackets are readily accessible at all times.

Your dealer can help you select appropriate life jackets (PFDs) and throwable lifesaving devices for your area. Some PFDs are specially made for use while water skiing or wakeboarding and are not USCG-approved. Please check local law with respect to their use. Some states require children to wear a PFD at all times. There are four types of wearable PFDs (Type I, II, III or V) and one throwable type of PFD (Type IV) used for throwing in emergency situations. Examples of these USCG-approved PFDs are shown:

Type I PFD —Offshore Life Jacket:

This PFD is designed for extended survival in rough, open water. It usually will turn an unconscious person face up and has over 22 pounds of buoyancy. This is the best PFD to keep you afloat in remote regions where rescue may be slow in coming.

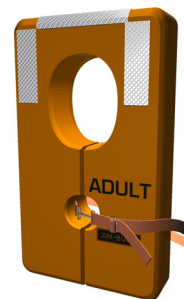

Type II PFD—Near Shore Buoyant Vest:

This “classic” PFD comes in several sizes for adults and children and is for calm inland water where there is chance of fast rescue. It is less bulky and less expensive than a Type I, and many will turn an unconscious person face up in the water.



Type III PFD—Flotation Aid:

These life jackets are generally considered the most comfortable, with styles for different boating activities and sports. They are for use in calm water where there is good chance of fast rescue since they will generally not turn an unconscious person face up. Flotation aids come in many sizes and styles.

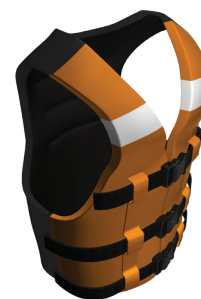

Type IV—Throwable Device:

These are designed to be thrown to a person in the water. Throwable devices include boat cushions, ring buoys, and horseshoe buoys. They are not designed to be worn and must be supplemented by wearable PFD. It is important to keep these devices immediately available for emergencies.



Type V PFD—Special Use Device:

Special use PFDs include work vests, deck suits, and hybrids for restricted use. Hybrid vests contain some internal buoyancy and are inflatable to provide additional flotation. These PFDs may be used instead of a Type I, II, or III PFD with non-towed participants if used in accordance with the approval conditions on the label and if worn when the boat is underway. Some Type V PFDs provide increased protection against hypothermia.



NOTICE

A Type V PFD must be worn to be counted toward the minimum carriage requirements.

NOTICE

Special life jackets are available for skiing and other water-sports. These non-Coast Guard-approved life jackets do not count as PFDs.



Fire Extinguisher

A portable fire extinguisher is required if your boat has an inboard engine, or when fuel is stored in closed stowage compartments.

Approved fire extinguishers are classified by a letter symbol, either B-I or B-II with the B designating that the material will extinguish flammable liquids such as gasoline, oil, etc. B-I extinguishers are required for boats less than 26 feet in length. Check periodically to ensure that the extinguisher is in working condition and fully charged. Check local, state and federal agencies as to laws and regulations.



Horn or Whistle

All boats over 16 feet (4.8 meters) in length must be equipped with an operable horn or whistle. Test the operation of the horn periodically, so as to make sure it will sound when you actually need to alert someone or another boat. The following are standard signals when using a whistle or a horn:

- **One prolonged blast:** Warning.
- **One short blast:** Pass on my port (left) side.
- **Two short blasts:** Pass on my starboard (right) side.
- **Three short blasts:** My engines are in reverse.
- **Five or more blasts:** Danger!



Bilge Pump(s)

Bilge pump(s) are installed in your boat to remove water that may accumulate in the bilge. Know the location of the pump(s), where they discharge, and where switches are located. Typically, there are manual switch and/or an automatic switch position(s).

Periodically test the operation of bilge pumps by activating the manual switch and observing the water discharge. It is best to leave the bilge pump switches in automatic mode, so as to not allow excess water to unknowingly accumulate in the bilge of your boat. If your bilge pump comes on too frequently or continuously, investigate the source of leaking water (check for hull damage, hose or piping leaks, missing drain plug, exhaust system or ballast system failures, etc.), and/or return to shore. Excess water in the bilge of your boat can cause loss of engine power, sinking, and/or capsizing.



Visual Distress Signals

 USE DAY ONLY	 RED DISTRESS FLARE (HAND) USE DAY AND NIGHT
 ARMS SIGNALS (USE BRIGHT CLOTH) USE DAY ONLY	 USE DAY ONLY SIGNAL (HAND)
 ELECTRIC DISTRESS LIGHT USE NIGHT ONLY	 RED METEOR FLARE USE DAY AND NIGHT
	 DYE MARKER USE DAY ONLY

COB_0031_A

All vessels used on coastal waters, the Great Lakes, territorial seas, and those waters connected directly to them up to a point where a body of water is greater than two miles wide, must be equipped with USCG-approved visual distress signals. Your dealer or local authorities can help you select appropriate visual distress signals for your area.

If you are required to carry distress signals, you must have three USCG-approved pyrotechnic devices. Be sure they are in serviceable condition, not exceeding the expiration date and stored in a cool, dry location in a red or orange waterproof container.



Pyrotechnic signaling devices can cause fire and/or explosion, death, serious injury, and property damage if improperly handled. Follow the pyrotechnic manufacturer's directions.



Radio Communications

Radio communication is the most important avenue of receiving and sending information. Use a VHF/FM radio for short-range communication, and a single-sideband radio (SSB) for long-range. For all U.S. waters, the National Weather Service operates the NOAA Weather Radio (NWR). This service provides continuous weather information the following *VHF/FM frequencies*:

162.400 MHz 162.500 MHz
162.425 MHz 162.525 MHz
162.450 MHz 162.550 MHz
162.475 MHz

Coast Guard Marine Information Stations

2670.0 kHz 8765.4 kHz
4428.7 kHz 13113.2 kHz
6506.4 kHz

It is good practice to periodically monitor the weather, even on seemingly fair-weather outings.

VHF/FM Channel 16 and SSB 2183 kHz are designed for emergency use. Such situations can be categorized as:

- **Emergency**
“MAYDAY, MAYDAY, MAYDAY”—Used when a life or vessel is in imminent danger.
- **Urgency**
“PAN-PAN, PAN-PAN, PAN-PAN” (pronounced *PAHN-PAHN*)—Used when a person or vessel is in some jeopardy less than indicated by a Mayday call.
- **Safety**
“SECURITY, SECURITY, SECURITY” (pronounced *SAY-CURE-IT-TAY*)—Used for navigational safety or weather warning.

An emergency situation will be hectic and there will not be time to learn proper radio procedure. **LEARN WHAT TO DO BEFORE YOU NEED TO DO IT.**

When a distress call occurs, stop all radio transmission. If you can directly assist, respond on the emergency frequency. If you cannot assist, do not transmit on that frequency. However, continue to monitor until it is obvious that help is being provided.

Note that some areas may require a license to operate radio-telephone equipment. Consult an authorized Cobalt dealer for information.



Recommended Safety Equipment

As a precaution, a prudent boater will avoid potential problems on an outing by having additional equipment on board. Normally, this equipment is dependent on the size and type of the body of water and the length of the trip. Your dealer can assist you in acquiring this additional equipment.

We recommend the following equipment:

- First aid kit and manual
- Anchor with at least 75 feet (23 meters) of line
- Mooring lines and fenders
- Bailing device (bucket, hand pump)
- Binoculars
- Combination paddle/boat hook
- Local charts and compass
- Day (flag)/night (flares) distress signals
- Waterproof flashlight and spare batteries
- Cellular phone
- Waterproof container for cell phone
- GPS Global Positioning System
- Emergency Position Indicating Radio Beacon (EPIRB)
- Binoculars
- Portable AM/FM radio with weather band
- A non-electric horn or whistle
- Extra engine oil
- Tool kit
- Spare propeller and mounting hardware
- Spare fuses
- Spare keys
- Sunglasses and sun block lotion



Recommended Spare Equipment

The following list contains common equipment that should be carried onboard to be available to make minor repairs as necessary.

- Lanyard for ignition safety switch
- Engine oil and generator oil
- Hydraulic fluid for the steering system and trim system
- Ignition keys
- Tape, tie straps and rope
- Light bulbs and fuses
- Propeller with attaching hardware

Life Raft

When operating offshore, consider carrying an inflatable life raft. A USCG-approved life raft meets a number of stringent specifications. The life raft must be large enough to hold all the boat's occupants and have its own equipment pack, including a paddle.

A life raft can be stored in the aft storage area or in any other accommodating location on the boat.

GENERAL BOATING SAFETY TOPICS

Safe Speed

Navigation rules state that a boat be operated at a safe speed at all times. Determination of a safe speed involves consideration of many factors, such as, but not limited to:

- Boating activity (tubing, water skiing, wakeboarding, wake surfing, etc.)
- Boat traffic congestion
- Water conditions
- Environmental conditions (shoreline, docks, and depth of water)
- Weather
- Visibility

The boat should not be driven at a rate of speed faster than will allow it to be brought to a full stop within the operator's field of view given the environmental conditions at the time. Safe speed for the conditions and driver attention (lookout) are important factors in avoiding collisions which may cause injury or death. When in doubt it is prudent to slow down within adequate time and distance so as to be able to assess the conditions and paths of other boats.

It is important to know the *Rules of the Road*, although do not assume that all boaters also know the rules or that they will abide by them. Avoid collisions by constantly assessing the ever-changing situation and be sure to make appropriate speed and course changes early.



Passenger Safety

The operator of the boat is responsible for the safety of the passengers, all skiers/riders, as well as his/her own safety. Ensure that you and your passengers adhere to these safety recommendations:

- Any time you take your boat out, make sure that there is at least one other passenger aboard who is familiar with the operation of your boat.
- Ensure that all passengers are properly and securely

seated in appropriate seating locations to avoid falling or falling overboard.

- While the engine(s) is running, and while the boat is maneuvering, all occupants should be properly seated. **DO NOT** stand while the boat is moving.
- **DO NOT** sit on the engine box (where equipped), seat backs, transom seating, sun pad, swim platform or gunwales while the boat is underway. You could fall overboard and be hit by the propeller, or another boat.
- **DO NOT** allow objects, arms or legs, or any other body parts to hang over the bow or gunwales. Stay within the boat.
- Passengers should not sit in locations that obstruct the operator's visibility.
- Persons and gear should be stowed in a way that distributes weight appropriately and in a manner that trims the boat properly (pitch angle). Excessive weight at either the bow or the stern relative to one another can cause trim problems leading to reduced driver visibility, erratic steering, loss of control, or bow submergence and flooding/swamping.
- Passengers should be well aware of emergency equipment and instructed in its use.
- Passengers should assist with lookout duties and notify the operator of any approaching watercraft or potentially unsafe conditions to provide assistance with collision avoidance.



Carbon Monoxide Safety

Carbon Monoxide (CO) is a deadly, colorless and odorless gas produced by all engines and fuel-burning appliances. Even with the best boat design and construction, plus the utmost care in inspection, operation and maintenance, hazardous levels of carbon monoxide may be present in or near the boat under certain conditions. The boat owner,

operator, as well as all boat occupants, must understand the dangers of carbon monoxide and must comply with all safety recommendations/ requirements. For boats with cabins, always ventilate the boat interior and avoid boating situations which cause increased exposure.



Carbon monoxide (CO) can cause brain damage or death. Engine and generator exhaust contains odorless and colorless carbon monoxide gas. Carbon monoxide will be around the back of the boat when engines or generators are running. Move to fresh air, if you feel nausea, headache, dizziness, or drowsiness.

- **DO NOT** allow people to be on or near the swim platform or in the water near the swim platform while the engine is running. Carbon monoxide will exist around the back of the boat when engines are running.
- **DO NOT** operate the engine in a confined space or while the boat is tethered to another vessel.
- **DO NOT** go under the boat cover while the engine is running or shortly after the engine has been running. Carbon monoxide may be trapped under the cover. It is important to remove the cover and/or ventilate the area before going under the boat cover.
- **DO NOT** “platform/teak” surf or platform drag. Carbon monoxide will exist in high concentrations in the vicinity of the swim platform near the water while the engine is running. The USCG has deemed platform dragging as a dangerous and hazardous activity which should be prohibited, as it can result in injury or death.
- In the event that someone exhibits the symptoms of carbon monoxide exposure (nausea, headache, dizziness, or drowsiness), have them breathe fresh air and, if necessary, immediately seek medical attention.

Hazardous boating situations involving carbon monoxide include:



Blockage of boat exhaust by obstruction.

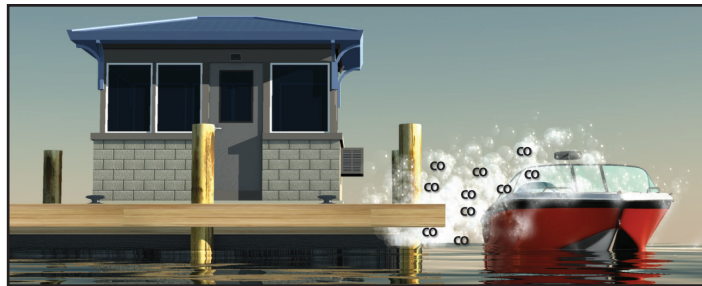

Exhaust traveling along obstruction.

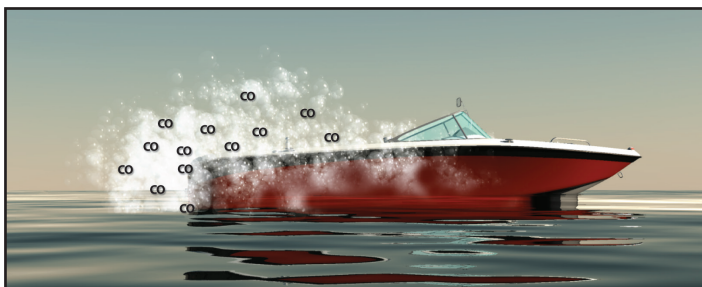

Operating at slow speed or while dead in the water.

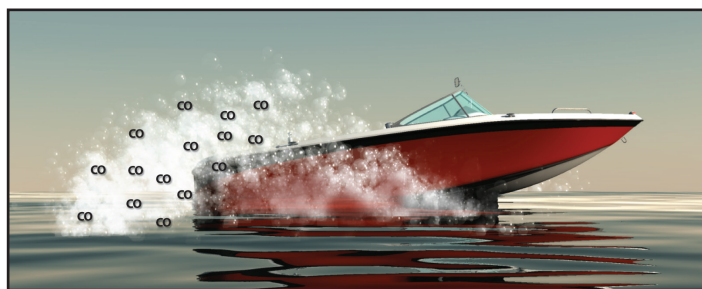

Operating with high bow angle.



Exhaust from other vessels in confined areas.

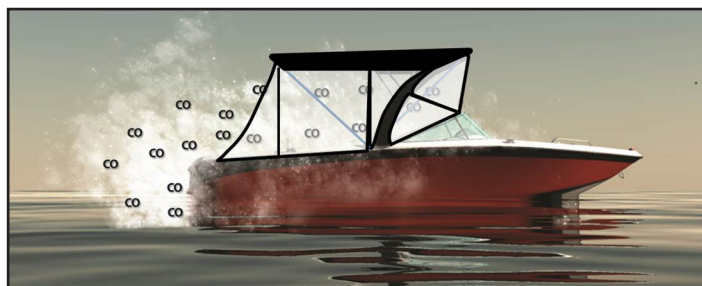

Operating with canvas tops and side curtains in place without ventilation.

For the most current information on carbon monoxide, you may call, write or visit online any of the following:

United States Coast Guard
Office of Boating Safety (CG-5422)
2100 Second Street SW STOP 7581
Washington, DC 20593-7581
(www.uscgboating.org/safety/carbon_monoxide.aspx)

NMMA
231 S. LaSalle St., Suite 2050
Chicago, IL 60604
312-946-6200
(www.nmma.org)

American Boat & Yacht Council, Inc.
613 Third Street, Suite 10
Annapolis, MD 21403
410-956-4460
(www.abycinc.org)



Proper Loading



WARNING

DO NOT overload your boat. Overloading or uneven loading can cause loss of control, capsizing, or swamping, which may lead to death or serious injury. Adhere to the load capacity plate restrictions, and always account for persons, gear, and all non-factory-installed ballast or other equipment.

Your boat is equipped with a maximum load capacity plate indicating the maximum acceptable load as determined by the manufacturer following certain Federal guidelines. In addition to following these weight guidelines, it is critical that you properly distribute this weight throughout the boat. If too much weight is placed in one area it can have serious impact on the boat's handling and control, which has the potential to lead to injury or death.

The maximum load capacity plate is used by boat manufacturers participating in the National Marine Manufacturers Association certification program. Your manufacturer has submitted your model for inspection and compliance with their guidelines. The maximum number of persons allowed on the boat has been determined by the manufacturer and displayed on the capacity plate. (Additional information regarding weight distribution appears elsewhere in this owner's manual.) This information on the capacity plate applies under normal conditions, and special care must be used in any abnormal conditions. Check the capacity plate on your boat and abide by these limits.

The capacity plate has the following information perma-

nently printed on it:

- ***The total weight of persons, gear and other items which the boat is capable of carrying under normal conditions. This weight must include any added ballast above and beyond boat manufacturer's factory-installed ballast system(s), such as the manufacturer's-approved, optional Plug 'n Play (which has been factored into the maximum capacity) or any other added, but unapproved ballast.***



WARNING

Any non-factory-installed ballast must be properly secured to prevent injury.



WARNING

DO NOT fill the bilge area with water. Excessive water in the bilge can cause changes in boat trim and reduce boat stability which may lead to submergence or capsizing.



Weighting Your Boat During Watersport Activities

Although water intrusion and waves spilling inside a boat is an obvious boating hazard, this hazard can be increased when weighting your boat for water sports such as wakeboarding or wake surfing. As wakeboarding has evolved, ballast systems have been developed to add weight and increase the size of the wake. The simplest ballast system on the market is the water ballast type, such as the "FAT SAC." The quest for the largest wake has caused some boat operators to excessively overload their boats. It is not uncommon to see operators use aftermarket ballast systems and then put additional people and gear in their boat. Be advised that this practice can lead to overloading your boat which may lead to any of the following: changes in handling and performance; capsizing, flooding, and sinking; boat occupants going overboard. **DO NOT** overload your boat.

Always be aware of the load in your boat and do not load the boat in excess of the listed capacity. Each boat has a maximum capacity label displaying the maximum weight of people, gear and ballast that can be placed in the boat.

When loading your boat, give attention to the effect that the load distribution has on the boat's trim angle. Trim angle is the technical term for the up or down pitch angle of your boat (also known as the "bow up" or "bow down" angle). The fore and aft load distribution of weight, passenger, and gear can affect the running trim angle of the boat.

- Excessive weight placed in the stern of the boat can cause the inability to get on plane, high bow-up angles, and can lead to steering difficulties. High bow-up angles can be dangerous due to the reduction in the operator's forward visibility which can lead to collisions and

groundings. High bow-up angles cause longer transition times from displacement mode (slow velocity, 0 to 5 mph) to planing speeds (18 to 20 mph and above). During transition, it is important that the boat operator pays attention so that they are able to see forward and that the time in transition (or in the “hump” speed region) is minimized.

- Excessive weight placed in the bow of the boat can lead to very flat planing trim angles which may lead the boat to turn aggressively, unpredictably, and without steer input. The phenomenon of yaw instability is caused by heavy bow weights and running very flat (bow down or flat trim angles). This can occur with excessive weight in the bow compared to weight in the stern of the boat. Another ill effect of too much bow weight in comparison to stern weight is that with extremely heavy bow loads, the boat’s bow may dive or submerge when coming off plane (decelerating rapidly or encountering waves/wakes at slow speed). If the bow submerges, then water will enter and flood your boat.
- When encountering conditions which may lead to bow diving or bow submergence, it is recommended to accelerate the boat before the wave/wake in order to help raise the bow and get over the wave/wake.
- If the bow submerges, the recommended action is to reduce throttle to stop forward speed, get passengers to move aft, and turn on the bilge pump.

It is the boat operator’s responsibility to tell passengers to move to other seats on the boat, so as to not overload the stern or bow of the boat, nor restrict the boat operator’s forward visibility. There is no single recommended seating or load distribution for all conditions. Experience with your boat will allow you to determine where to properly allow passengers and gear to be placed.

⚠ WARNING

Excess and improper loading of bow area forward of windshield may cause water influx, operating instability, and loss of control resulting in injury or death. Bow Capacity Limit—X persons or XXX lbs. person, gear and ballast. This is posted separately on your boat but still included in overall capacity. Use good judgment when weighting your boat for any towed water sports.



Visibility for the Operator

The operator of the boat is responsible, by law, to “maintain a proper lookout by sight and hearing.” The operator must ensure that he/she has appropriate visibility for safe operation. No passengers or equipment should block the operator’s view, including the view of other boats, skier(s), rider(s), swimmer(s), or anyone or anything else in the water. Even momentary interference can result in the driver’s inability to respond to a situation that requires avoidance of another vessel or submerged or partially submerged object(s).

Look carefully before turning, especially when you are turning around to pick up a fallen skier/rider. Other boats in your vicinity may not necessarily be following the nautical Rules of the Road. Be alert and keep a visual check for other boats in and around your intended path. Do not turn or maneuver your boat without first checking that it is clear to do so. Failure to look before turning can result in an encounter with another boat where neither boat has enough time to avoid a collision. This situation can develop very quickly if you fail to look first and turn in front of another oncoming boat.

⚠ WARNING

Obstructed visibility can cause death or serious injury. The operator must maintain clear visibility at all times while operating the boat. Arrange passengers and equipment appropriately or designate a passenger to assist when visibility is limited.



Boating Under the Influence



Operating the boat or boating under the influence of alcohol and/or drugs can cause serious injury or death. Alcohol and drugs slow your reaction time and impair your judgment. Do not operate a boat or allow passengers to boat while under the influence of alcohol and/or drugs.

Boating under the influence of alcohol or drugs can be deadly. Alcohol and/or drug use is the leading contributing factor to all recreational boating fatalities. Alcohol and drugs can increase your reaction time and impair your judgment. Combined with the sun, wind, waves, and noise of other watercraft, the effects of drugs and alcohol can be increased and can significantly increase your reaction time. As the owner/operator, you are responsible for the alcohol/drug use and onboard behavior of your passengers. Additionally, civil lawsuits in cases of property damage or injury/death to others can result in significantly higher verdicts when alcohol or drugs are allowed.



Impaired operation may result in severe personal injury or death. Federal and state laws prohibit operating a boat under the influence of alcohol and other drugs. If the operator's blood alcohol content is above the legal limit, violators are subject to fines and may go to jail. Violators may also lose automobile driving privileges.



Product Misuse

Misuse of the product or use of it in a manner for which it was never intended can create dangerous situations. The boat operator and passengers are responsible for using the product safely and as intended. The driver must operate the boat in a manner that ensures the safety of all passengers. If you or your passengers are unsure about the proper use of the product, unsure about performing certain boating maneuvers or are unsure about a particular water activity, refer to this owner's manual or contact a knowledgeable source, such as your local dealer, the US Coast Guard, or your local boating authority.



Reporting Accidents

Boat operators may be required by law to file a Boating Accident report with their state boating law enforcement agency or local authority, the USCG, or their country's boating law enforcement agency when their boat is involved in certain boating accidents. A boating accident must be re-

ported if there is a loss or probable loss of life or a personal injury requiring medical attention beyond first aid. In these situations, a formal report must generally be filed within 48 hours of the accident. Also, a boating accident must be reported for accidents when damage exceeding \$500 is incurred, or there is a complete loss of the boat. In these situations, a formal report must generally be filed within ten (10) days. If any of these events occur, seek further assistance from local law enforcement personnel. Please note that the submittal of a report is the responsibility of the boat owner. This requirement is different than laws associated with the reporting of automobile accidents.



Rendering Assistance

If you see a distress signal or suspect a boat is in trouble, you must assume it is a real emergency and render assistance immediately. By law, the operator in charge of the craft is obligated to provide assistance to any individual in danger, presuming assistance can be safely provided. Failure to render assistance can result in a fine and/or imprisonment.

The 1971 Boating Safety Act grants protection to a "Good Samaritan" boater providing good faith assistance and absolves a boater from any civil liability arising from such assistance.



Hazardous Conditions

Every waterway poses hazards that should be avoided. You will be best prepared to avoid these hazards if you are familiar with the waterway where you are boating. Whenever possible familiarize yourself with navigation charts, depth charts, and waterway maps before you go boating. The following information outlines some of the most common hazards which may be encountered:

Shallow Water Operation

Shallow water brings on obvious hazards such as sand bars, stumps, rocks, etc. Know the area in which you will be operating the boat. Grounding the vessel or striking submerged objects can result in serious injury or death and can cause severe damage to your watercraft. At high speed, this can cause rapid deceleration or stop your boat abruptly, which may cause occupants to impact the interior of the boat or be ejected. Stick to deeper water whenever possible, and if you must travel in shallow water, proceed at low speed and post a lookout.

Know the minimum depth your boat can safely travel.

Warning Markers

Learn to recognize the different buoys and day markers; they are used as the signposts of the waterways identifying navigable routes and water hazards. It is a good idea to ask local authorities about hazard areas and if they are marked. Stay within boundaries and clear of hazards.

Weeds

Weeds can generally be a threat to a boat's engine and other components on the boat. If weeds wrap around the propeller, they can create vibration in the engine(s). They also can restrict water intakes or clog the water filter, causing the engine(s) to overheat. Learn to recognize the typical normal operating temperature range for your engine(s). If temperature rises high above normal, then check for blockage of the engine cooling water system.

NOTICE

Weeds can sometimes be removed by shifting to NEUTRAL, pausing for a moment, then shifting to REVERSE to unwind the weeds from the propeller.

Dam Spillways

The area around dam spillways is very hazardous and conditions can change rapidly. Keep clear of the spillways and areas below dams. Currents created by spillways can draw in objects, including your boat.

Restricted Areas







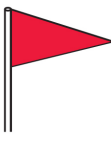

Before boating, check with Local, State, and Federal authorities to identify restricted areas. Because of the threat

of terrorism, the U.S. Coast Guard has and will continue to implement strict limits on watercraft near U.S. Navy and Coast Guard ships and other potential targets.

Weather/Seas

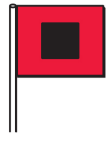
Learn and understand weather patterns and signs of change. Bad weather can cause an uncomfortable and unsafe situation. If a storm approaches, seek a safe harbor. Check forecasts before getting underway and continue to monitor conditions while on the water.

The following are storm signals:

DAYTIME WARNING	DESCRIPTION	NIGHTTIME WARNING
	Small Craft Advisory - Winds greater than 18 knots, sustained for two hours or more or hazardous wave conditions. Following a storm, hazardous wave conditions can persist long after the high winds have subsided.	
	Gale Warning - Sustained winds (2 or more hours), of 34-47 knots.	
	Storm Warning - Sustained winds of 48 knots or greater.	
	Hurricane Warning - Forecast winds of 64 knots and above. Displayed only in connection with a hurricane.	

COB_0032_A



Environmental Concerns

As a boater, you already appreciate nature's beauty and the peace of the great outdoors. It is a boater's responsibility to protect the natural environment by keeping waterways clean.

Foreign Species

If you trailer your boat from lake to lake, you have the potential of unknowingly introducing a foreign aquatic species from one lake to the next. It is important to thoroughly clean the bottom of the boat below the water line, remove all weeds and algae, and drain the bilge, ballast, and livewells before launching the boat in a new body of water. Check local, state, country agencies as to laws and regulations.

Fuel/Oil Spillage

The spilling of fuel or oil into our waterways contaminates the environment and is dangerous to wildlife. **DO NOT EVER** discharge or dispose of fuel, oil or other chemicals into the water; it is prohibited and can result in fines. These are three common, accidental types of discharge:

- During initial fueling of a nearly empty tank
- Overfilling the fuel tanks
- Pumping contaminated bilge water



Fumes from rags can collect in the bilge and pose an extremely hazardous fire and explosion risk, which can result in injury or death. Never store rags used to wipe up fuel or solvent spills in the boat. Dispose of rags properly ashore.

Discharge/Disposal of Waste

Waste means all forms of garbage, plastics, recyclables, food, wood, detergents, sewage and even fish parts in certain waters—in short, nearly everything. We recommend you bring back everything you take out with you, for proper disposal ashore.

Excessive Noise

Noise means engine noise, radio noise, music, loud conversation, or even yelling. Many bodies of water have adopted noise limits. Noise can carry a considerable distance on water, especially at night. Be sure to follow regulations and be courteous.

Speed/Wake/Wash

Be alert for **NO WAKE** zones. You are responsible for any damage or injury caused by your wake/wash. Prior to entering a **NO WAKE** zone, reduce throttle, come off plane to the slowest steerable speed. Use caution when operating around smaller crafts, in channels and marinas, and in congested areas.

Some states and boating areas have imposed speed limits for the operation of boats, including, but not limited to, no-wake zones. Check local, state, and federal agencies as to laws and regulations. The U.S. Coast Guard and local boating authorities are excellent sources for this information, which can include penalties for failure to observe the requirements.

Exhaust Emissions

Increased exhaust (hydrocarbon) emissions pollute our water and air. Keep your engine(s) tuned and boat hull clean for peak performance. Consult your Cobalt dealer for information.

Paints

If your boat is kept in water where marine growth is a problem, the use of anti-fouling paint may reduce the growth rate. Be aware of environmental regulations that may govern your paint choice. Contact your local boating authorities for information.

Cleaning Agents

Household cleaners should be used sparingly and not discharged into waterways. Never mix cleaners and be sure to use plenty of ventilation in enclosed areas while cleaning your boat. **DO NOT** use products which contain phosphates, chlorine, solvents, non-biodegradable or petroleum-based products. Refer to the *Care and Maintenance* section in this manual for more information.

MARPOL Treaty

The USCG enforces the International Convention for the Prevention of Pollution from ships, commonly referred to as the MARPOL Treaty (Marine Pollution). This treaty prohibits the overboard dumping of all ship-generated plastics, chemicals, garbage and oil.



California Air Resource Board (CARB) Label

The boat may have an environmental star label affixed on the bow port side of the boat as part of the California Air Resource Board (CARB) SD/I rule. This label must stay affixed to the boat if it is operated in California. The label confirms that the boat is equipped with a California Certified Engine. The label is positioned so it will be at the leading or trailing edge of the state registration numbers.

(More information about the star ratings system appears in the *Engine* section of this owner's manual.)



Proposition 65



A wide variety of components used on this vessel contain or emit chemicals known to the state of California to cause cancer, birth defects and other reproductive harm.

EXAMPLES INCLUDE:

- Engine and generator exhaust.
- Engine and generator fuel, and other liquids such as coolants and oil, especially used motor oil.
- Cooking fuels.
- Cleaners, paints and substances used for vessel repair.
- Waste materials that result from wear of vessel components.
- Lead from battery terminals and from other sources such as ballast or fishing sinkers.

TO AVOID HARM:

- Keep away from engine, generator and cooking fuel exhaust fumes.
- Wash areas thoroughly with soap and water after handling the substances above.

ON-PRODUCT WARNING LABELS

Warning Labels & Locations

Warning labels are placed at specific locations on your Cobalt boat at the time of manufacture to alert you to potential hazards that may not be obvious. These labels also indicate how to avoid these hazards. *Warning labels should never be removed and must remain legible.* If you suspect a label is missing, or if a label becomes damaged or becomes unreadable (damaged, faded, or sun-bleached), contact your dealer for replacement.

It is the responsibility of the boat owner and occupants of the boat to understand and comply with all warning labels and safety recommendations/requirements. The driver of the boat and the boat owner are responsible for the

proper operation of the boat and the safety of the occupants of the boat. Failure to adhere to and comply with the on-product warning labels and safety statements labeled as dangers, warnings, and cautions that appear in this manual can lead to serious injury, or death, as well as property damage. **READ AND ADHERE TO ALL WARNING PLATES AND LABELS** from bow to stern, including those that are installed inside the engine compartment, lockers, and underneath seating.

Not all the following labels will appear on every boat or in the same location. Check all labels from bow to stern.

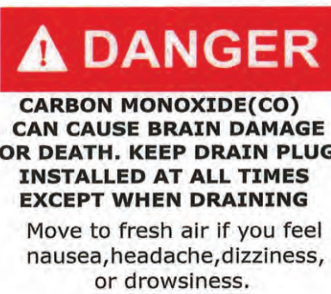
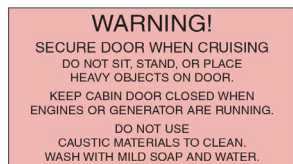
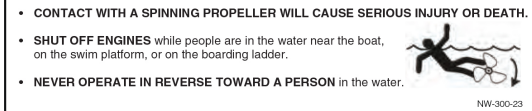
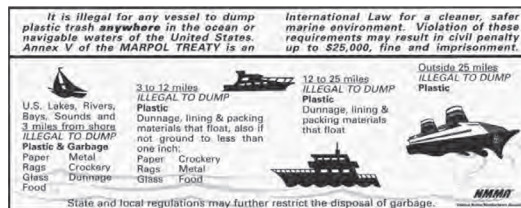
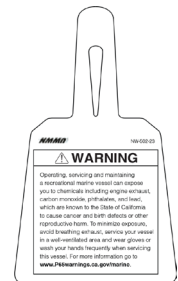
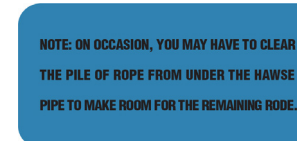
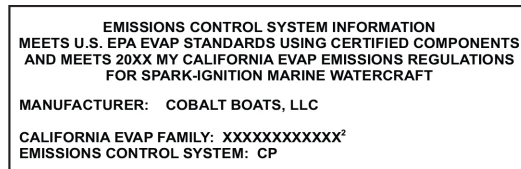
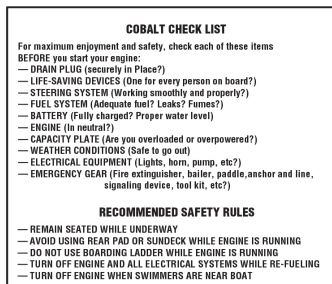
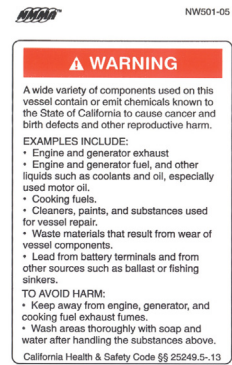
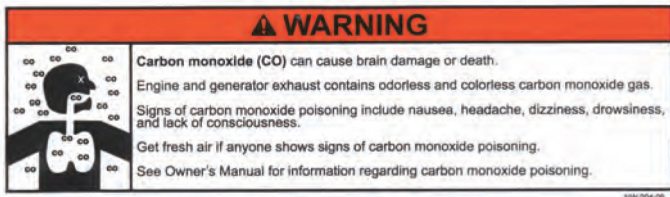

Labels on this page usually are located in the helm area or the forward portion of the boat.

WARNING

LEAKING FUEL IS A FIRE AND EXPLOSION HAZARD. INSPECT SYSTEM REGULARLY. EXAMINE FUEL SYSTEM FOR LEAKS OR CORROSION AT LEAST ANNUALLY.

© NMMA 1990/NO.200

WARNING

PINCH POINT
PINCH POINT CAN CRUSH HAND OR FOOT.
KEEP HANDS AND FEET CLEAR WHEN STEP IS MOVING.



CAUTION

AVOID DAMAGE
KEEP PLATFORM CLEAR WHEN IN MOTION. MAXIMUM HOLDING CAPACITY IS 1,000LBS.

DISCHARGE OF OIL PROHIBITED

THE FEDERAL WATER POLLUTION CONTROL ACT PROHIBITS THE DISCHARGE OF OIL OR WASTE INTO OR UPON THE NAVIGABLE WATER OF THE UNITED STATES OR THE WATERS OF THE CONTIGUOUS ZONE IF SUCH DISCHARGE CAUSES A FILM OR SHEEN UPON OR A DISCOLORATION OF THE SURFACE OF THE WATER OR CAUSE A SLUDGE OR EMULSION BENEATH THE SURFACE OF THE WATER. VIOLATORS ARE SUBJECTED TO A PENALTY OF \$5000.

WARNING

PROPELLER LOCATED BEHIND THIS BOAT. CONTACT MAY CAUSE SEVERE INJURY OR FATALITY. DO NOT APPROACH OR USE LADDER AND PLATFORM WHEN THE ENGINE IS RUNNING.

WARNING

DO NOT OCCUPY EXTENDED SWIM PLATFORM WHILE ENGINE IS RUNNING OR ENGAGED. PROPELLER CONTACT MAY CAUSE SEVERE INJURY OR FATALITY. ALL GASOLINE POWERED ENGINES PRODUCE CARBON MONOXIDE (CO). CO IS COLORLESS, ODORLESS, AND DANGEROUS. DIRECT AND PROLONGED EXPOSURE TO CO WILL CAUSE BRAIN DAMAGE OR DEATH.

WARNING

EXTENDED SWIM PLATFORM MUST BE ATTACHED WHILE BOAT IS IN USE TO AVOID POSSIBLE INJURY OR DROWNING. SWIM LADDER IS ATTACHED TO THE PLATFORM.

REMOVABLE FEATURE IS FOR BOAT STORAGE PURPOSES ONLY.

CAUTION

MOVING MACHINERY
POTENTIAL DAMAGE
OUTDRIVE WILL LOWER BEFORE SWIM PLATFORM DESCENDS

WARNING

AVOID OBSTRUCTION OF NAVIGATION LIGHTS AND POSSIBLE COLLISION. REMOVE CANVAS BEFORE USING NAVIGATION OR ANCHOR LIGHTS.

WARNING

Keep hands and feet away from drive unit when tilting.

WARNING

Rotating Shaft Can Cause Severe Injury
Keep arms, legs, hair and loose clothing away.

WARNING

Do not tow or occupy floating device while underway or when engine is running.
Can cause injury or death

WARNING

BIMINI AND ATTACHED ANCHOR LIGHT MUST BE INSTALLED FOR NIGHTTIME BOATING

WARNING

AVOID DAMAGE OR INJURY. DO NOT USE AS A TOW POINT.

WARNING

AVOID DAMAGE OR INJURY. DO NOT EXCEED TOW POINT MAXIMUM LOAD OF 1000 POUNDS.



BASIC RULES OF THE ROAD

Boating Regulations

The U.S. Coast Guard (USCG) is the governing authority of the United States waterways and serves to help the boating public. State boating regulations are enforced by local authorities. Owners and users outside of the United States must be cognizant of that country's laws and regulations. You are subject to marine traffic laws and nautical Rules of the Road for both federal and state waterways; you must stop if signaled to do so by enforcement officers and permit them to board if asked.

Review and understand all local, state, federal, and country boating laws.

Increasingly, governmental bodies are establishing new laws, rules and regulations regarding specific water activities. Because of the widespread interest in wakeboarding and wake surfing, the state in which you are wakeboarding/wake surfing may:

- Require operators to stay a specific distance from all shorelines, docks, piers or other structures. That means the channel or body of water will need to be of a defined width to be considered acceptable.
- Require riders engaging in towed watersports to wear a U.S. Coast Guard-approved life jacket.
- Prohibit wakeboarding/wake surfing during the hours between sunset and sunrise.
- Prohibit wake surfing behind a boat with an exposed propeller that extends beyond the boarding platform.
- Prohibit wakeboarding/wake surfing on small bodies of water, i.e., less than fifty (50) acres.

Even in areas not governed by similar laws, these kinds of requirements and limitations represent a common-sense approach to recreation.

There are many USCG pamphlets available to you. These pamphlets go beyond the contents of this manual and explain Rules of the Road, signal lights, buoys, safety, international and inland regulations. An example is *The Ultimate Watersports Handbook* you should have received with your new boat, or which can be ordered by contacting WSIA; go to: www.WSIA.net. For more information, contact your local USCG Unit or visit <http://www.uscgboating.org>.

You should be aware of these rules and follow them whenever you encounter another vessel on the water. The rules presented in this manual outline only the most basic of the nautical Rules of the Road and have been provided as a convenience only. Consult your local U.S. Coast Guard Auxiliary (USCGA), Department of Motor Vehicles (DMV) or local maritime authority for a complete set of rules governing the waters in which you will be using your boat. If you plan to travel—even for a short trip—you would be well-served to contact the regional USCGA or DMV in the area where you will be boating.

The nautical Rules of the Road must be followed to prevent collisions between vessels. Like traffic laws for automobiles, the operator is legally required to follow the rules.



Collisions between boats can cause death or serious injury. Keep a proper lookout, safe speed, and follow the nautical Rules of the Road.



Encountering Another Vessel

Any time two vessels on the water meet one another, one vessel has the right-of-way. It is called the “stand-on” or “privileged vessel.” The vessel which does **NOT** have the right-of-way is called the “give-way” or “burdened vessel.” These rules determine which vessel has the right-of-way, and accordingly, what each vessel should do.



Privileged Vessel

The privileged vessel has the right-of-way and has the duty to continue its course and speed, except to avoid an immediate collision. When you maintain your direction and speed, the other vessel will be able to determine how best to avoid you.

NOTICE

In general, boats with less maneuverability have right of way over more-agile crafts. You must stay clear of the vessel with right-of-way and pass to his stern.

Sailboats and boats paddled or rowed have the right-of-way over motorboats. Sailboats under power are considered motorboats. Small pleasure craft must yield to large commercial boats in narrow channels.



Burdened Vessel

The burdened vessel does not have the right-of-way and has the duty to take positive and timely action to stay out of the way of the privileged vessel. Normally, the burdened vessel should not cross in front of the privileged vessel. The burdened vessel should slow down or change directions and pass behind the other vessel. The burdened vessel operator should always move in such a way that the privileged vessel operator can see what you are doing in ample time to avoid a collision.

Crossing

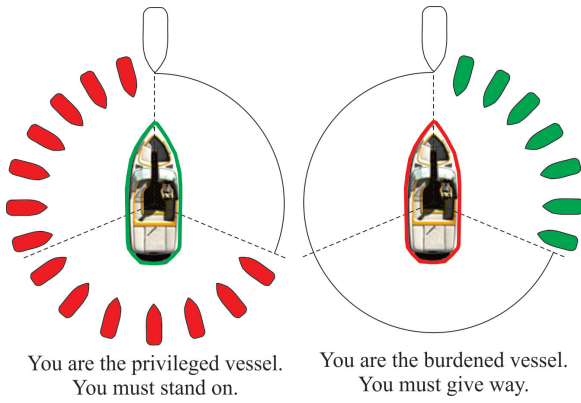

In crossing situations, the boat to the right from the 12 o'clock to the 4 o'clock position has the right-of-way, and it must hold course and speed. The burdened boat passes behind the privileged boat. Boats going up and down a river have the privilege over boats crossing the river. The illustration depicts a situation in which you are the boat in the center, and you are the privileged vessel. You must hold course and speed. All vessels approaching your vessel from the directions depicted by the red vessels must yield to your boat.

Conversely, the illustration depicts a situation in which you are the boat in the center, and you are the burdened vessel. You must give right-of-way to all vessels coming towards you from the directions shown in green.



Meeting Head-On

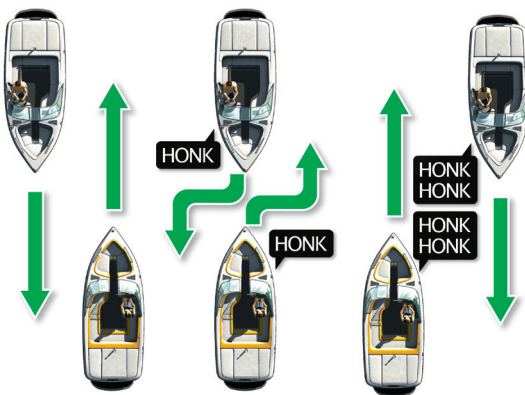

When meeting head-on, neither vessel has the right-of-way. Both boats should decrease speed, turn towards their right (starboard side) and pass on their left sides (port-to-port). However, if both boats are clearly on each other's right (starboard) side then, each vessel should sound two short blasts and pass on their right sides (starboard-to-starboard).



Overtaking

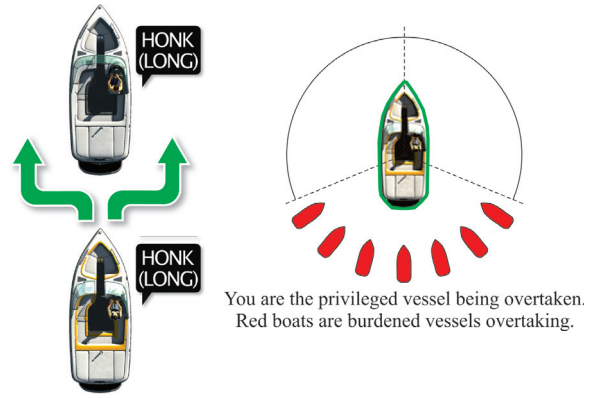

The boat that is overtaking one ahead of it is the burdened boat and must make any adjustments necessary to keep out of the way of the privileged boat, until the burdened boat is well ahead and clear of the vessel being overtaken.



The General Prudential Rule

The General Prudential Rule regarding right-of-way, is that if a collision appears unavoidable, neither boat has right-of-way. As prescribed in the Rules of the Road, both boats must act to avoid collision.

Rule 2 in the International Rules says, "In construing and complying with these Rules due regard shall be had to all dangers of navigation and collision and to any special circumstances, including the limitations of the vessels involved, which may make a departure from these Rules necessary to avoid immediate danger."



Other Rules of the Road

When navigating in narrow channels, you should keep to the right when it is safe and practical to do so. If the operator of a power-driven vessel is preparing to go around a bend that may obstruct the view of other water vessels, the operator should sound a prolonged blast on the whistle or horn—four (4) to six (6) seconds.

If another vessel is around the bend, it too should sound the whistle or horn. Even if no reply is heard, however, the vessel should still proceed around the bend with caution.

If you navigate this type of waters, you should carry a portable air horn, which is available from local marine supply stores.



Aids to Navigation

Learn to recognize the different buoys and day markers; they are the signposts of the waterways. The United States Aids to Navigation System (USATONS) is the primary marking system used on inland waters, coastal waters and rivers in the United States. This system is maintained by the U.S. Coast Guard (USCG).

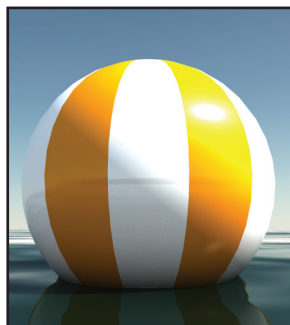

Spherical Safe Water Marker

There are two primary marking systems in use in the U.S.: the Uniform State Waterway Marking System (USWMS), used on inland waters and maintained by each state, and the Federal Waterway Marking System (FWMS), used on coastal waters and rivers and maintained by the USCG. In addition, the FWMS has two modified systems: the Western River Buoyage, and the Intracoastal Waterway Buoyage. Be sure to check with local authorities on the buoyage system in use in your boating region.

The type of hazard/warning buoys and markers depends on the area of jurisdiction. Check with local boating authorities.

USWMS System

In the USWMS Lateral System, well-defined channels are marked with red and black buoys, and the boat should pass between them.

The USWMS Cardinal System is used when there is no well-defined channel or where an obstruction may be approached from more than one direction. With the cardinal system:

- Pass north or east of **BLACK-TOPPED WHITE** buoy.
- Pass south or west of **RED-TOPPED WHITE** buoy.
- **RED and WHITE VERTICALLY STRIPED** buoy indicates boat should pass outside of the buoy (away from shore).

FWMS System

The FWMS Lateral System is for use on navigable waters except Western Rivers and Intracoastal Waterways. The markings on these buoys are oriented from the perspective of being entered from seaward (the boater is going toward the port). This means that red buoys are passed on the starboard (right) side of the vessel when proceeding from open water into port, and green buoys to the port (left) side.

The right side (starboard) of the channel is marked with **RED**, even numbered buoys.

The left (port) side of the channel is marked with **GREEN**, odd numbered buoys.

The middle of the channel is marked with **RED and WHITE** vertically striped buoys; pass close to these buoys.

Obstructions, channel junctions, etc. are marked with

RED and **GREEN** horizontally striped buoys.

A **RED** band at the top means the preferred channel is to the left of the buoy; a **GREEN** top band means the preferred channel is to the right of the buoy.

Day markers are colored and numbered the same as buoys. **RED**, triangular day markers with even numbers mark the starboard side of the channel. **GREEN**, square day markers with odd numbers mark the port side of the channel.

Lights, bells and horns are used on buoys for night or poor visibility conditions. Buoys with unique light flashing characteristics are identified on nautical charts with the specific flashing pattern.

Types of Buoys

There are several types and shapes of buoys. Buoys may be unlighted, lighted, with sound or may have both an audible and a visual signal. Lights, bells and horns are used on buoys for night or poor visibility conditions. Different shapes of buoys are shown following.

Buoys with unique light flashing characteristics are identified on nautical charts with the specific flashing pattern.

Mooring Buoys

The only buoys from which you are permitted to moor are mooring buoys. Mooring buoys are white with a blue horizontal stripe. Mooring to a navigation buoy, regulatory markers or lateral markers is illegal.

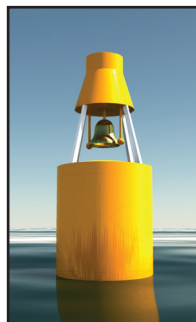

UNLIGHTED BELL BUOY



SPAR BUOY

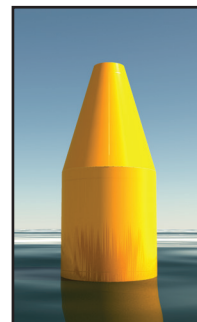

NUN BUOY

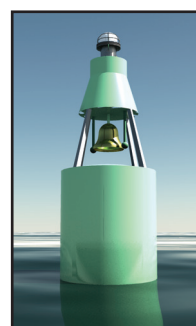

LIGHTED BUOY

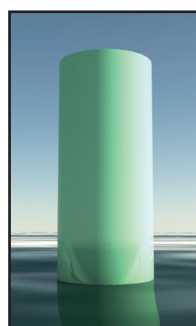

CAN BUOY



MOORING BUOY

Uniform State Regulatory Markers

Regulatory markers indicate dangerous or restricted controlled areas. These markers are used to indicate speed zones, areas set aside for particular use, general information and directions.

Regulatory markers are white with orange geometric shapes and also have orange bands near the top and at the water line of the buoy. You must obey regulatory markers.

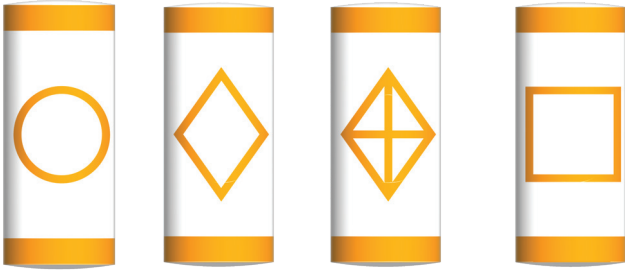

CONTROLLED AREA DANGER BOATS KEEP OUT INFORMATION

Uniform State Waterway Marking System (USWMS)

THERE ARE OTHER SYSTEMS OF MARKERS. IT IS THE RESPONSIBILITY OF THE BOAT OPERATOR TO DETERMINE WHICH MARKING SYSTEM IS IN USE IN THE BODY OF WATER IN WHICH THE OUTING WILL OCCUR. UNDERSTAND AND ABIDE BY ALL MARKING SYSTEMS.



Diver's Flag

Used by recreational divers—indicates position. Stay far away from diver flags. Someone is underwater in the vicinity.

Alpha Flag

Worldwide vessels engaged in diving operations—does not indicate diver's position.



Distress Flag

Indicates fellow boater is in need of assistance.

Warning Markers

It is a good idea to ask local authorities if there are hazardous areas and how they are marked. Boaters must also recognize the flag designs, which indicate that skin divers are present and keep well clear of the area. Divers underwater cannot be seen. Stay well away from boats or floats displaying Diver Flags.

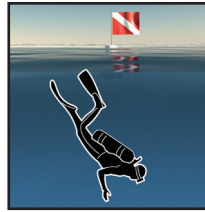

Skin Diver Warning



Swim Area Warning

Watch for swimmers. Swimming areas may not be marked. Steer clear from the area and remain alert.

Navigation markers serve as a means of identifying navigable routes and indicate water hazards. Boaters should become familiar with navigation markers and stay within marked boundaries and clear of hazards.



Night Running

Operation of your Cobalt boat between sunset and sunrise in some locations may be restricted or not allowed at all. It is the responsibility of boat owners and boat operators to verify the laws, rules and regulations regarding nighttime operation for the body of water upon which you are running.

Boats operating between sunset and sunrise (hours vary by state) must use navigational lights. Nighttime operation, especially during bad weather or fog can be dangerous. All Rules of the Road apply at night, but it is best to slow down and stay clear of all boats, regardless of who has right-of-way. Protect your night vision by avoiding bright lights and have a passenger, if possible, help keep watch for other boats, water hazards and aids to navigation. It is best to proceed slowly at night, as there is always the possibility of unlit boats, floating objects, and fixed objects which will be very difficult to see in time to avoid if you are at planing speeds or above.

There are many light patterns on different types of boats and for boats performing various functions while underway or at anchor. For most applications on recreational boats the following navigation light patterns are applicable.

(NOTE: Information is included here that does not apply to Cobalt boats. However, the information is included to assist Cobalt operators in being aware of the navigational lights that may appear on other vessels you may encounter.)

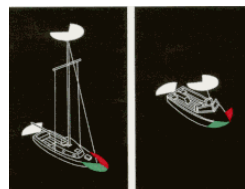

Figure 1

Motorboats less than 20 meters (65.62 feet) shall exhibit navigation lights as shown in Figure 1. *(Note: Two masthead lights are optional for boats under 50 meters. Boats over 50 meters [164 feet] will display two masthead lights.)*

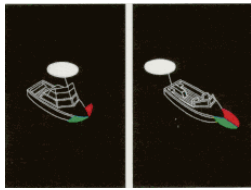

Figure 2

Motorboats of less than 12 meters (39 feet, 4 inches) in length, may show the lights in either Figure 1 or Figure 2. Boats of less than 7 meters (23 feet) whose maximum speed cannot exceed seven (7) knots may

exhibit an all-around white light, and, if practicable, side-lights instead of the lights prescribed above, in international waters only.

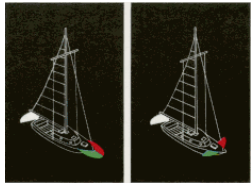

Figure 3

Sailboats and watercraft under oars: Sailboats less than 20 meters (65.62 feet) may exhibit the navigation lights shown in Figures 3 or 4.

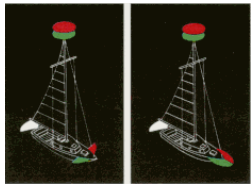

Figure 4



Figure 5

Another option for sailboats is to use a single combination lantern at the top of the mast as shown in Figure 5.

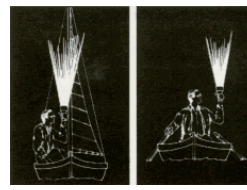

Figure 6

Sailboats less than 7 meters (22.96 feet) may carry an electric torch or lighted lantern showing a white light to be displayed in sufficient time to prevent collision (see Figure 6). If practicable the lights prescribed for

sailboats less than 20 meters should be displayed. Watercraft under oars (such as a canoe) may display the lights prescribed for sailboats, but if not, must have ready at hand an electric torch or lighted lantern (flashlight) showing a white light to be displayed in sufficient time to prevent collision (see Figure 6).

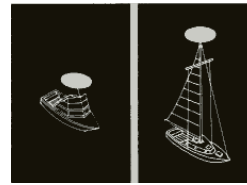

Figure 7

Anchored boats: Motorboats and sailboats at anchor must display anchor lights. An anchor light for a watercraft less than 50 meters (164 feet) in length is an all-around white light, visible for two (2) miles exhib-

ited where it can best be seen (see Figure 7).

Sailboats operating under machinery, or under sail and machinery, are considered power-driven and must display the lights prescribed for a power-driven boat.

WATERSPORTS SAFETY

Skiers or riders are obligated to be aware of the same fundamental safety rules as boat operators. If you are new to water skiing, wakeboarding, wake surfing, and other towed watersports, seek certified training before starting. You will find it especially helpful to join a local ski club, World Wakeboard Association, and/or USA Water Ski, when possible.

Always remember that the majority of injuries occurring while water skiing/wakeboarding and other towed watersports are the result of impacts with other objects. Always look where you are going and be aware of what is going on around you.

When participating in towing watersports, be safe and courteous and follow these guidelines:

- Be considerate to fishermen and others who are sharing the same body of water.
- **DO NOT** perform watersports in congested areas.
- Stay away from navigation markers.
- Stay away from other boats and watersports participants.



Contact with a spinning propeller can cause injury and death. Do not enter or exit the water when the engine is running (ON) and the propeller spinning. DO NOT get on the swim platform when the engine is running. DO NOT swim towards the back of the boat if the engine is on.



Failure to adhere to these warnings may result in severe injury or death to you and/or others.

- Every towed person must always wear a USCG-approved personal flotation device.
- Always have an experienced driver and a designated observer in the boat while being towed.
- Maintain a distance of at least 100 feet from all other objects, including other boats, piers, rafts, mooring and navigational buoys, pilings, abutments, or any other items.

- Never water ski, wakeboard or participate in other towed watersports in shallow water, close to shore, or in water where you do not know the depth or what is beneath the surface.
- Never put your arm, head, or any other part of your body through the handle-bridle of the tow line nor wrap the line around any part of the body at any time.
- **DO NOT** participate in watersports while under the influence of alcohol and/or drugs.
- **DO NOT** participate in watersports during inclement weather or on rough water.
- Never water ski, wakeboard or participate in other towed watersports directly in front of other boats who may run over you if you fall.
- Never water ski, wakeboard or participate in other towed watersports at night.
- Never jump from a boat that is moving at any speed.
- Make sure that everyone knows and uses approved towed watersports hand signals.



Hand Signals

Make sure that everyone knows and uses approved towed watersports hand signals, as shown.



CIRCLE BACK TO DOCK CUT ENGINE



SKIER IN WATER SKIER OK SPEED OK



STOP SPEED FASTER SPEED SLOWER



TURN LEFT TURN RIGHT



Towed Person Safety Responsibilities

Most injuries and fatalities that occur on high-performance recreational tow boats occur to the persons being towed (water skiing, knee-boarding, wakeboarding, wake surfing, tubing, etc.). It is the responsibility of the boat operator to pay attention to a multitude of things while utilizing the boat for water tow sports. The towed person has little or no control over their path nor do they have much in the way of protection from impact with obstacles or other boats. Therefore, it is recommended that boat operators, observers, and towed persons communicate effectively and clearly as to their intentions and their surroundings. The main responsibilities for each participant are as follow:

Operators should:

- Assign a passenger to be a designated observer.
- Turn the engine(s) off whenever a person is on the swim platform or in the water near the boat. This is especially important for the area near the back of the boat to avoid propeller injuries.
- Ensure that it is “all clear” behind the boat when starting the engine(s). Ask for verbal confirmation or hand signals that it is “all clear” behind the boat. Then, and only then, start the engine(s).
- Keep their main focus on maneuvering the boat safely while avoiding other boats, fixed objects, the shore, and shallow water.
- Use rear view mirrors to allow the driver to glance at the towed person, while still keeping their main attention on the path of the boat and the surroundings.
- Return safely to pick up towed persons or persons in the water. Keep the individual in view, approach slowly (preferably on the driver’s side), and shut off the engine(s) when close to an individual in the water. **DO NOT** back up or operate the boat in reverse to a person in the water.

Observers should:

- Confirm for the boat operator that it is “all clear” behind the boat prior to starting the engine.
- Watch the towed person.
- Be responsible for communication of the signals and status of the towed person to the boat driver.
- Notify the boat operator of status and changing conditions with the towed person and inform the boat driver of the towed person’s readiness to start, their desire to go faster or slower, or that they have fallen and are in need of retrieval.
- Deploy the fallen skier flag when the towed person falls, if needed. In some states, it is required to raise the “fallen skier” flag when the skier has fallen.
- Monitor the tow line to ensure that it does not become tangled, it does not become wrapped around anyone in the boat, and it does not become wrapped around the

towed person. Also monitor the tow line so that it does not become tangled in the propeller. Notify the boat operator if any of these conditions are observed to avoid potential injury.

- Remind the boat operator to shut off the engine(s) when persons are on the swim platform or in the water near the back of the boat.

Towed persons should:

- Wear a PFD.
- Not approach the back of the boat if the engine(s) is running.
- Not become entangled in a tow line or wrap a tow line around any body part.
- Know signals to communicate with the observer and boat operator.



Additional Precautions for Towed Skier/Rider

- Wear wet suits or protective shorts when engaging in high energy skiing/riding to prevent abrasions, hypothermia, and injuries to orifices (rectal and vaginal) from impact with the water surface.
- Inspect watersports equipment for wear, fraying, etc., before use. **DO NOT** use if they show signs of wear or fraying. Ropes or watersport equipment tow points may break during use, causing you to coast into obstacles or fall with the risk of being struck by another vessel.
- Inspect the boat tow points before use. If there is any evidence of corrosion or other damage, do not use until it has been inspected by your authorized Cobalt Boat dealer.
- **NEVER** attach ski/wakeboard rope to anything but approved pylons and wakeboard towers. Make sure tow ropes are properly attached to the boat tow points.
- The skier/rider should verbally indicate that (s)he is safely clear of the boat prior to operator starting the boat engine or putting the boat into gear.
- Slowly take up slack in tow lines before accelerating to watersports speeds. Jerking the slack out of a tow line can cause high forces on the rope and towing equipment. This may cause the rope or equipment to break and the rope to snap back at occupants of your boat and at the towed person.
- Never put your arm, head or any other part of your body through the handle/bridle of the ski or wakeboarding line, nor wrap the line around any part of the body at any time. If you fall, the line will tighten and forcefully constrict around your body part and may result in amputation.
- **DO NOT** ski near swimming areas, beaches, personal watercraft, or other vessels/boats.
- Never attempt land or dock starts. These activities will increase your risk of injury or death.
- **DO NOT** jump from a boat that is moving at any speed, nor enter or exit the water when the engine is running.
- **DO NOT** “back up” to anyone in the water; they will be in danger of hitting the spinning propeller which can cause severe injury or death.
- **DO NOT** follow directly behind another boat or skier/rider without leaving an adequate safe distance in case that towed person falls into the water. You will need ample time and distance to maneuver your boat away from that person in the water and to avoid their tow boat which will be circling back to retrieve their downed person.
- **DO NOT** participate in towed watersports at night. It is illegal and other boats will not be able to see you, nor will they anticipate or expect your presence behind the towing boat. Furthermore, once you fall, they will not see you swimming.
- **DO NOT** tow with multiple skier/riders with different length ropes.
- **DO NOT** ski in limited visibility conditions.
- Never climb, sit or stand on a wakeboard tower. The wakeboard tower is intended for towing only as noted. It is designed to pull a limited number of individual(s), and in some cases only one (1) individual. Please consult the remainder of this owner’s manual and warning labels on the tower for details. The wakeboard tower approved for use on your boat should be used only for water skis, wakeboards or recreational towables, and not for parasailing, kite flying or towing other boats.
- Many states require the use of “skier down” flags. Check your local lake and state requirements. Having the observer raise a skier down flag when your towed watersport participant falls down or off the towed device will alert boats around you to the fact that someone is in the water nearby and that they should avoid the area.
- Many lakes have recommended tow patterns. Other boats may expect that you know the local customs and practices. It is common that the tow pattern is counterclockwise around the lake, but there are exceptions. Check for local recommendations or requirements.
- **NEVER** lift or trailer the boat with water in the bilge or in ballast tanks. Lift or trailer per manufacturer’s instructions.
- Around marina docks where electrical current is present (such as shore power connections) it is unsafe to swim as stray electrical currents may exist, which can cause you to drown.



Tow Line Guidelines

Tow lines come in different lengths and strengths for different activities. Make sure any line you are using is suited for skiing or riding and that it is in good condition.

- Never use a tow line that is frayed, knotted, unraveling or discolored from use or being left in the sun. If a line breaks while in use it can recoil at the skier/rider being towed or into the watercraft where it might strike passengers. Replace tow lines with any sign of damage.
- Never use a tow line with elastic or bungee material to pull skiers or riders.
- Tow line should be attached to the watercraft in an approved fashion with hardware designed for towing. Refer to your watercraft manual for instructions on proper tow line attachment.
- Always route tow lines away from the propeller, even when idling. Shut off the engine if your boat starts to cross a floating tow line.
- If a tow line should become entangled in a propeller, shut off engine, remove the key and put it in your pocket before retrieving the line.
- Tow lines should be neatly coiled and stowed in the boat when not in use.



Fallen Skier or Rider

Falling and injuries are common in water skiing and other towed watersports. Keep tow speeds in a comfortable range given the rules of the activity and the skill level of participants.

- Display a red or orange skier/rider down flag to alert other vessels that a skier/rider is down. In some states, it is required to raise the “fallen skier” flag when the skier has fallen.
- Turn the boat and slowly circle toward the person in the water to return the tow line handle or towed device to that person.
- Always keep the fallen skier/rider in view and preferably on the operator’s side of the watercraft.
- Put the watercraft in neutral whenever you are near a fallen skier/rider.
- Shut off the engine when retrieving someone from the water or if the person in the water gets too close to the boat. Do not trust neutral gear with an idling engine. Someone may accidentally or prematurely shift the gear, or the linkages may be out of adjustment and the propeller may still be slowly spinning.



Develop WATER SENSE

The Watersports Responsibility Code and the Watersports Safety Code have been developed by WSIA and industry equipment manufacturers. These Codes are reproduced here for your reference.

WATERSPORTS SAFETY CODE

Before you get in the water: Skiing or riding instruction is recommended before use. Instruction will teach general safety guidelines and proper skiing or riding techniques, which may reduce your risk of injury. For more information on skiing or riding schools, contact your dealer, association, or local ski club.

- Know the federal, state and local laws that apply to your area.
- If you are not familiar with a waterway, ask someone who is knowledgeable to tell you about any hidden dangers or things to avoid.
- Whether you plan to be in a watercraft, or skiing/riding behind one it is important you are wearing a properly fitted life jacket (PFD) approved by your country’s agency, USCG Type III, ISO, etc.
- Inspect all equipment prior to each use, check bindings, fins, tube, attachment, tow rope and flotation device. **DO NOT** use if damaged.

Watercraft Safety: A knowledgeable and responsible driver is the most important safety device on any watercraft.

- Never operate a watercraft, ski or ride under the influence of alcohol or drugs.
- Use only water ballast and people for additional weight.
- Never exceed the passenger or weight limitations of the watercraft.
- Never allow passengers to hang outside the watercraft or towed device or sit on the gunwales or anywhere outside of the normal seating area.
- Never allow water to overflow the bow or gunwales of the watercraft.
- Uneven weight distribution or additional weight may affect the handling of the watercraft.

Carbon Monoxide: The exhaust from the engine on a watercraft contains Carbon Monoxide (CO) which is a colorless, odorless and poisonous gas. Excessive exposure to CO can cause severe injury or death. Follow this advice to avoid injury.

- Never “Platform Drag” by holding onto the boarding platform or being dragged directly behind the watercraft. This is where CO will be.
- **DO NOT** sit on the watercraft transom or the boarding platform while the engine is running.
- Make sure the engine is properly tuned and running



seasickness, intoxication or heat stress. If someone complains of irritated eyes, headache, nausea, weakness or dizziness, or if carbon monoxide is suspected, immediately move the complainant to fresh air, investigate the cause and take correction action. Seek medical attention when necessary.

Tow Ropes: Tow ropes come in different lengths and strengths for different activities. Make sure any rope you are using is suited for that activity and that it is in good condition.

- Never use a rope that is frayed, knotted, unraveling or discolored from use or being left in the sun. If a rope breaks while in use

well. An improperly tuned engine produces excessive exhaust and CO.

- If you smell engine exhaust do not stay in that position.
- Go to the United States Coast Guard's website: (www.uscgboating.org) for more information on how to help protect yourself and others from the dangers of CO.



Platform Dragging (“Teak Surfing”)

READ, KNOW and UNDERSTAND the information on warning labels and adhere to the boat operation practices described on them. The USCG issued a **SAFETY ALERT** on August 28, 2001, which covers some issues regarding improper use of the boarding ladder/swim platform. The **SAFETY ALERT** and portions of the information follow:

Tragic deaths occur from the negligence of unsafe boating and dangerous activities. Experts say, “Many of these deaths may have been caused by an invisible hazard, carbon monoxide poisoning.”

Taking the risk of swimming under a boarding platform when the engine is running, skiing within 20 ft (6.1m), or “teak surfing” or “dragging” behind a moving boat, and be fatal. Dangerous activities which can result in serious injury or death are not considered water sports.

Cobalt Boats does not promote unsafe boating risks or jeopardizing any boat's safety. Teak surfing or platform dragging may be illegal in the state in which the boat is operated.



DO NOT use the swim platform for any other purpose than boarding the boat or preparation for entering the water, and do not use the swim platform when engines are running. Carbon monoxide poisoning should not be confused with

it can recoil at the skier/rider being towed or into the watercraft where it might strike passengers. Replace tow ropes with any sign of damage.

- Never use a tow rope with elastic or bungee material to pull skiers or riders.
- Rope should be attached to the watercraft in an approved fashion with hardware designed for towing. Refer to your watercraft manual for instructions on proper tow rope attachment.
- Always keep people and tow ropes away from the propeller, even when idling.
- If a tow rope should become entangled in a propeller, shut off the engine, remove the key and secure it in a safe location before retrieving the rope.
- Tow ropes should be neatly stowed in the boat when not in use.

Preparing to Ski or Ride: Always have a person other than the driver act as an observer to look out for the skier/rider.

- Be sure the driver is aware of the experience and ability of the skier/rider.
- The driver, observer and skier/rider need to agree on hand signals before skiing or riding. Signals should include **READY, STOP, SPEED UP** and **SLOW DOWN**.
- Start the engine only after making sure that no one in the water is near the propeller.
- Turn the engine off when people are getting into or out of the watercraft, or in the water near the watercraft.
- Always make sure the tow rope is not wrapped around anyone's hands, arms, legs or other parts of the body.
- Start the watercraft and move slowly to remove slack until the tow rope is tight.
- When the skier/rider signals **READY** and there is no

traffic ahead, take off in a straight line. Adjust the speed according to the signals given by the skier/rider.

Skiing or Riding: The watercraft and skier/rider should always maintain a sufficient distance from obstacles so a skier/rider falling or coasting and/or watercraft will not encounter any obstacle.

- Do not use in shallow water or near shore, docks, pilings, swimmers, other watercraft, or any other obstacles.
- Use only on water.
- Never attempt land or dock starts. This will increase your risk of injury or death.
- Always wear a properly fitted life jacket (PFD) approved by your country's agency, USCG Type III, ISO, etc.
- The faster you ski or ride, the greater your risk of injury.
- Never make sharp turns that may cause a slingshot effect on the skier/rider's speed.
- The skier/rider should be towed at an appropriate speed for his or her ability level.

Fallen Skier or Rider: Falling and injuries are common in skiing or riding.

- Circle a fallen skier/rider slowly to return the tow rope handle or pick up the fallen skier/rider.
- Turn off the engine when near a fallen skier/rider.
- Always keep the fallen skier/rider in view and on the driver's side of the watercraft.
- Display a red or orange skier-down flag to alert other vessels that a skier/rider is down if required by the state in which you are operating.

The Warnings and practices in the Watersports Safety Code represent common risks encountered by users. The code does not cover all instances of risk or danger. Please use common sense and good judgment.

EMERGENCY PROCEDURES

In an emergency situation, you may have to resort to measures which are not commonly practiced. Always assess the dangers of being in harm's way versus the protection of equipment. Keep a sound mind during an emergency and always use common sense.

Explosion and Fire

Many boat fires and explosions involve flammable liquids such as gas or oil, which are used in your boat's propulsion engine(s) and generator. Carefully follow all warning labels and safety precautions while handling flammable substances. Many fires in inboard boats start in the bilge area due to gasoline vapors. Gasoline vapors are heavier than air and collect in the bilge of boats.



Explosion

- If explosion is imminent, put on PFDs, grab distress signals and survival gear, and immediately abandon ship.



Fire

- Immediately turn off engines, generators, stoves and blowers.
- Extinguish smoking materials.
- A fixed fire suppression system, if equipped, has heat sensors that automatically flood the machinery space

with a fire extinguishant. Allow extinguishant to "soak" the compartment for at least 15 minutes to cool the hot metals or fuel before cautiously inspecting the fire area. Have portable fire extinguishers ready. **DO NOT** breathe fumes or vapors caused by the fire or extinguishant.

- If no fixed fire suppression system is installed and a fire is in the engine compartment, discharge portable fire extinguishers through the engine compartment access plate, if equipped. **DO NOT** open the engine hatch as this feeds oxygen to the fire.
- If you have access to the fire, direct the contents of the fire extinguishers at the base of flames, not at the top.
- Throw burning materials overboard if possible.
- Move anyone not needed for firefighting operations away from the flames.
- Signal for help.
- Put on PFDs (Personal Flotation Devices), grab distress signals and survival gear, and prepare to abandon ship.



Burn hazard from gasoline floating on water which is ignited can cause death or serious injury. Gasoline will float on top of water and can burn. If the boat is abandoned, swim upwind, far enough to avoid fuel that can spread over the surface of the water.



Swamping and Flooding

In the event that the vessel begins to take on water, turn on the bilge pump to evacuate water and slow its accumulation, and try to determine the source of the water. A collision with an underwater object can cause the hull to develop a leak. A loose-fitting hose clamp on a piece of equipment can cause a leak. Try to repair the leak if possible. If a leak is threatening the safety of you and your passengers, call or signal for assistance.

- Turn on bilge pump(s).
- Access PFDs, pass them out to everyone, and put them on.
- Identify source of leak and try to stop the leak and flooding.
- **STAY WITH THE BOAT!** A boat will usually float even if there is major hull damage. Rescuers can spot a boat much easier than a head bobbing in the water.
- Signal or call for help.
- If others were on board, try to locate them, make sure that they are conscious and that they can swim.
- Immersion in water speeds the loss of body heat and can lead to hypothermia (the abnormal lowering of internal body temperature).



Capsizing

- If others were on board, try to locate them, make sure that they are conscious and they can swim.
- If possible, access life jackets (PFDs), pass them out to everyone, and put them on.
- **STAY WITH THE BOAT!** A boat will usually float even if there is major hull damage. Rescuers can spot a boat much easier than a head bobbing in the water.
- Signal or call for help.
- Immersion in water speeds the loss of body heat and can lead to hypothermia (the abnormal lowering of internal body temperature).



Staying Afloat

- Remain calm. Do not thrash about or try to remove clothing or footwear. This leads to exhaustion and increases the loss of air that may keep you afloat.
- Keep your life jacket (PFD) on.
- Keep your knees bent.
- Float on your back and paddle slowly to safety.



Collisions

- Immediately account for all passengers.
- Check for injuries.
- If any person is in the water, make sure they have proper flotation devices.
- Assess the hull for damage.
- Activate the bilge pump(s) to reduce any flooding.
- Try to operate the boat to keep the damaged area above water.
- If necessary, call or signal for assistance.
- **STAY WITH THE BOAT!**



Grounding

In the event you run aground, assess the situation before proceeding. Your response to grounding will depend on how hard the boat hits bottom and whether the boat remains stranded, the extent of damage, and proximity to shore and help.

- If it is a simple touch, you may need only to inspect the hull.
- If you are aground, assess the situation before reacting. In some cases, throwing the boat into reverse can cause more damage.
- Check for leaks and immediately stop any water from entering the boat.
- Inspect the hull, steering system and propulsion system for damage.
- Maneuver the boat to safe water only if the hull and all operating systems are in satisfactory operating condition. Otherwise, call or signal for assistance.



Person Overboard

- Immediately react to a person who has fallen overboard by sounding an alarm.
- Keep the victim constantly in your sight.
- If another passenger is on board, assign them to look at and keep pointing at the person in the water. They are to do nothing else but stay focused on the person in the water and to point at them.
- Throw the person a life preserver even if they are wearing a PFD. It will serve as a marker in the water and will provide additional flotation.
- Immediately slow or stop the boat and safely circle toward the victim as soon as possible.
- Keep the victim on the helm side of the vessel so as to keep the victim constantly in your sight.
- When almost alongside, shut off the engine.
- Assist the person into the boat.

Unassisted Means of Reboarding

To reboard a boat:

- Move to the swim platform on the transom of the boat.
- Place both hands, palms down, onto the top of the platform.
- Using your legs to kick upwards, pull your body and legs up over the edge of the swim platform.
- Use the grab handles that are mounted to the transom of the boat to gain additional leverage.
- Lean into the swim platform and swing one leg up onto the swim platform. Then use the grab handle to provide support while pulling the rest of your body onto the swim platform.
- Stand up and maintain three points of contact with the boat. Use the transom step to climb back into the boat.



CAUTION

Be aware that there are metal surfaces mounted on the hull beneath the swim platform. Do not allow arms, legs, or body parts to extend before the swim platform as these surfaces may cause minor-to-moderate injuries.



Drowning

- Swim to rescue a drowning victim only as a last resort.
- **Immediate resuscitation is critical!** It may be possible to revive a drowning victim who has been under water for some time and shows no sign of life. Start CPR immediately and get the victim to a hospital as quickly as possible.
- Keep the victim warm.
- Use care in handling. Spinal injury may exist if the victim fell overboard.
- Call and signal for help.



Medical Emergency

In an emergency, you may be far from professional medical assistance. Be prepared and know how to use your first aid kit. Be aware of any special medical conditions of your passengers.



Operation Failure

If you experience a propulsion, electrical, steering or control failure, immediately shut off the engine(s). If it is safe to do so and you are qualified, then try to determine the cause of the failure and repair. Otherwise, call or signal for assistance. Anchor the boat if drifting will put you and others in danger.



WARNING

Towing or being towed stresses the boats, hardware and lines. Failure of any part can seriously injure people or damage the boat.



Towing

A recreational boat towing another should be a last resort due to the potential for damaging one or both boats. The Coast Guard or a private salvage company is better equipped for this activity. A recreational boat may assist by standing by, and possibly by keeping the disabled boat's bow at a proper angle until help arrives. Only when conditions are ideal—that is, waters are calm, disabled boat is small, appropriate hardware is available, and one or both skippers know the correct technique—should a recreational boat tow another.

Towing Vessel

- Be sure your boat will not run aground, too.
- Because you are maneuverable and the grounded boat is not, you should pass the towline to the grounded boat.
- Select an appropriately strong tow line. Use double-braided or braid-on-braid line. Never use three-strand twisted nylon; it has too much elasticity and can

snap back dangerously.

- Select an appropriate attachment point. If available, fasten the towline to the forward tow pylon of the towing boat. Otherwise fasten a tow line to a stern tow point. Fastening to the stern tow point will restrict maneuverability of the towing boat.
- If possible, use a bridle.
- Move slowly to prevent sudden strain on a slack line.
- Proceed at slow speed.
- Avoid abrupt changes in throttle as that may cause the tow line to slacken and jerk tight. Sudden strain or jerking the line causes excessive tow line forces which may part the line. Keep slack out of the tow line, but if it occurs proceed slowly to again take up the strain on the line and avoid sudden jerks in the line.
- Be ready to cast loose or cut the line if the towing situation becomes hazardous.

Vessel Being Towed

- Attach the towline to the bow eye.
- If it is necessary to be towed after being freed, keep someone at the wheel to steer.

Both Vessels

- If you attach the tow line to a fitting, be sure the fitting is fastened with a through bolt and is reinforced on the underside.
- Keep lines clear of propellers on both boats.
- Keep hands and feet clear of the other boat. Do not get caught or pinched between the two boats as severe injury could occur.
- Never hold a tow line after it is pulled taut.



Specifications



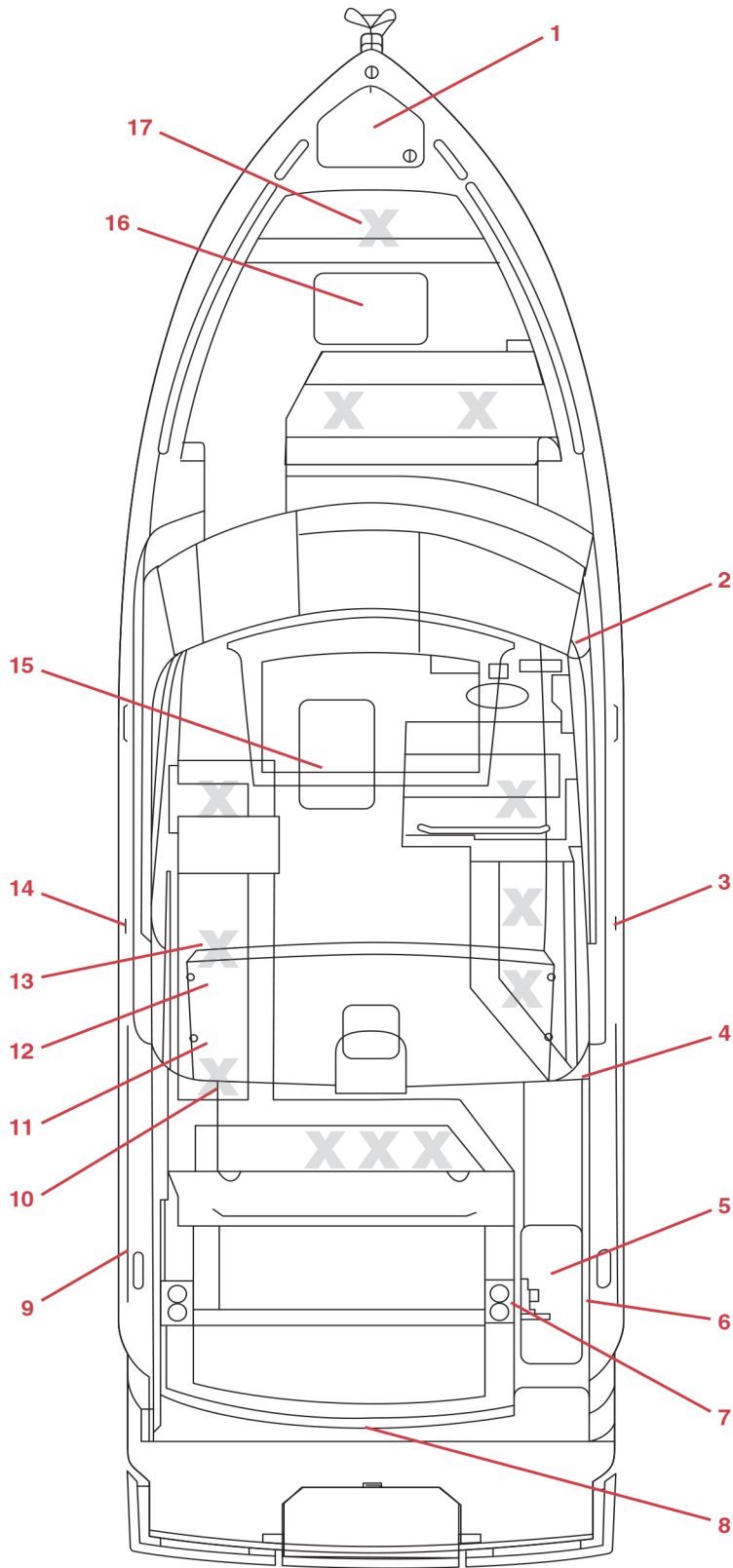

1. Anchor Locker
2. Ignition Safety Switch
3. Fuel Fill
4. Motor Box Switch
5. Aft Walk-Thru Storage
6. Optional Hydraulic Swim Step Switch
7. Optional Transom Shower
8. Ski Tow
9. Anchor Light Receptacle
10. Battery Selector Switch
11. Fire Extinguisher Storage
12. Ski Locker/Bimini Top Storage
13. Optional Air Compressor/Storage
14. Optional Water Fill
15. Cockpit Floor Storage
16. Bow Floor Storage
17. Bow Seat Storage

 12 Designated
 Occupant
 Positions

COB_0548_A

A29

A29 SPECIFICATIONS

Length Overall w/Swim Platform	29'0" 8.84 m
Beam	9'0" 2.74 m
Interior Cockpit Width	94" 2.39 m
Deadrise at Transom	21°
Fuel Capacity	121 gal 458 L
Fresh Water Capacity	18 gal 68 L
Bridge Clearance w/o Bimini	60" 1.52 m
Bridge Clearance w/Arch	94" 2.40 m
Bridge Clearance w/Hard Top	105" 2.67 m
Draft, Drive Up	28"71 m
Draft, Drive Down	38"97 m
Dry Weight	7,275 lbs 3,300 kg
Boat Certified Capacity	Yacht Certified
Boat Certified Capacity w/gear	Yacht Certified

MERCUISER STERNDRIVE POWER

8.2 Mag ECT B3X DTS	380 hp
8.2 Mag HO ECT B3X DTS	430hp

VOLVO PENTA STERNDRIVE POWER

V8-380-CE DP	380 hp
V8-430-CE DP	430 hp

A29



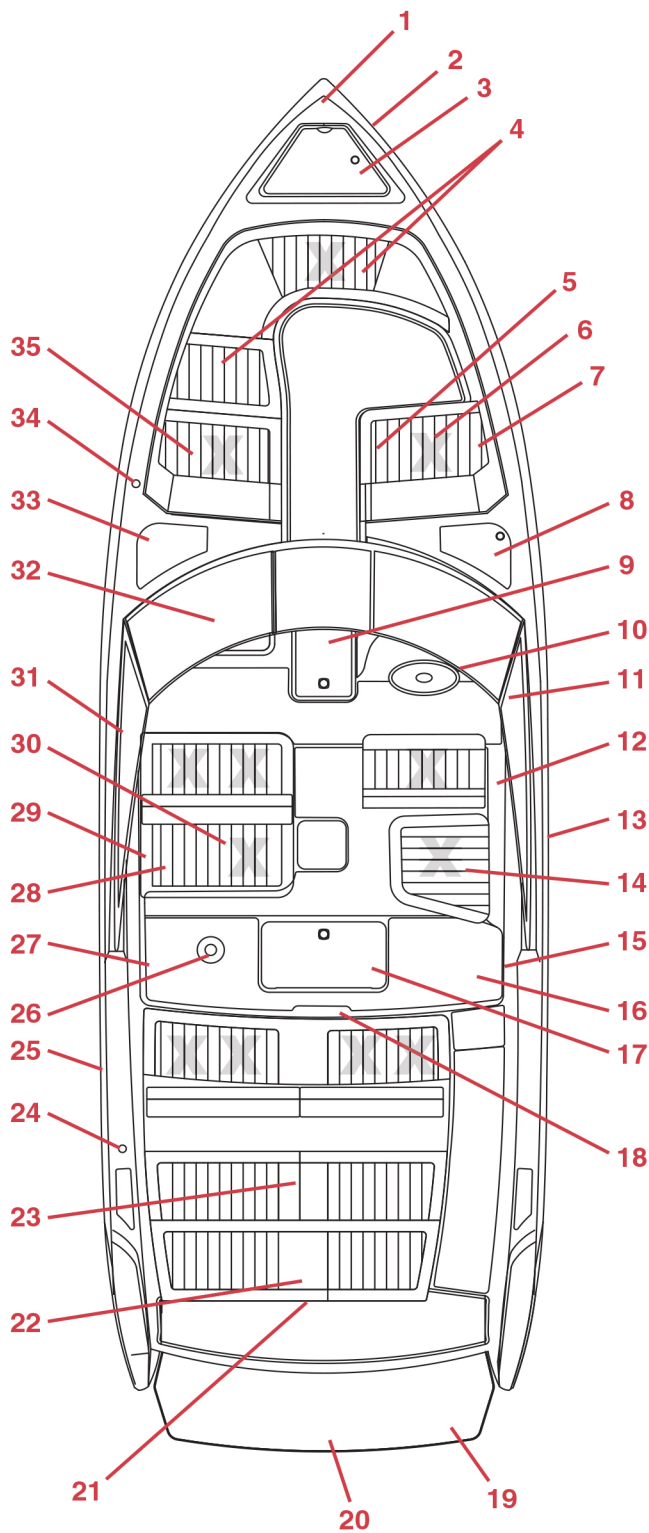

COB_0436_A

1. Bow Navigation Light
2. Docking Lights
3. Anchor Lid
4. Wet Storage
5. Fire Extinguisher
6. Storage
7. Air Compressor
8. Fender Storage
9. Ski Locker
10. Helm
11. Ignition Safety Switch
12. Remote Battery Switches
13. Fuel Fill
14. Insulated Ice Chest
15. Motor Box and Hydraulic Swim Platform Switches
16. Fuel Vent Carbon Canister
17. Wet Locker
18. Cockpit Drains
19. Swim Platform Boarding Ladder - Single Engine
20. Swim Platform Boarding Ladder - Twin Engine
21. Ski Tow
22. Aft Bilge Pump in Engine Compartment
23. Forward Bilge Pump in Engine Compartment
24. Anchor Light Receptacle w/o Arch or Bimini
25. Water Fill
26. Cockpit Filler Receptacle
27. Manual Battery Switches Located in Floor Storage
28. Removable Trash Can
29. Breaker Panel Jumper Studs
30. Removable Ice Chest
31. 12V Accessory Outlet
32. Head
33. Head Natural Light
34. Waste Pump-Out Fitting
35. VacuFlush Tank



R30

R30

R30 SPECIFICATIONS

Length Overall w/Swim Platform	30'8" 9.35 m
Beam	9'6" 2.90 m
Interior Cockpit Width	8'5" 2.57 m
Deadrise at Transom	21°
Fuel Capacity	116 gal 439 L
Fresh Water Capacity	18 gal 68 L
Holding Tank Capacity	9 gal 34 L
Bridge Clearance (windshield only)	5'0" 1.52 m
Draft, Drive Up, Single Engine	25"64 m
Draft, Drive Down, Single Engine	37"94 m
Draft, Drive Up, Twin Engine	27"68 m
Draft, Drive Down, Twin Engine	39"99 m
Dry Weight w/Single Engine	7,400 lbs 3,354 kg
Dry Weight w/Twin Engine	8,800 lbs 3,992 kg
Boat Certified Capacity	Yacht Certified
Boat Certified Capacity w/gear	Yacht Certified

MERCUISER STERNDRIVE POWER

8.2 Mag ECT B3X DTS	380 hp
8.2 Mag HO ECT B3X DTS	430 hp
Twin 6.2L MPI ECT 300 B3DTS Axius	300 hp
Twin 6.2L MPI ECT 350 B3DTS Axius	350 hp
Twin 8.2L Mag ECT B3X DTS Axius	380 hp
Twin 8.2L Mag HO ECT B3X DTS Axius	430 hp

VOLVO PENTA STERNDRIVE POWER

V8-380-CE DP	380 hp
V8-430-CE DP	430 hp
Twin V8 300CE-G DP Joystick	300 hp
Twin V8 350CE-G DP Joystick	350 hp
Twin V8 380CE DP Joystick	380 hp
Twin V8 430CE DP Joystick	430 hp

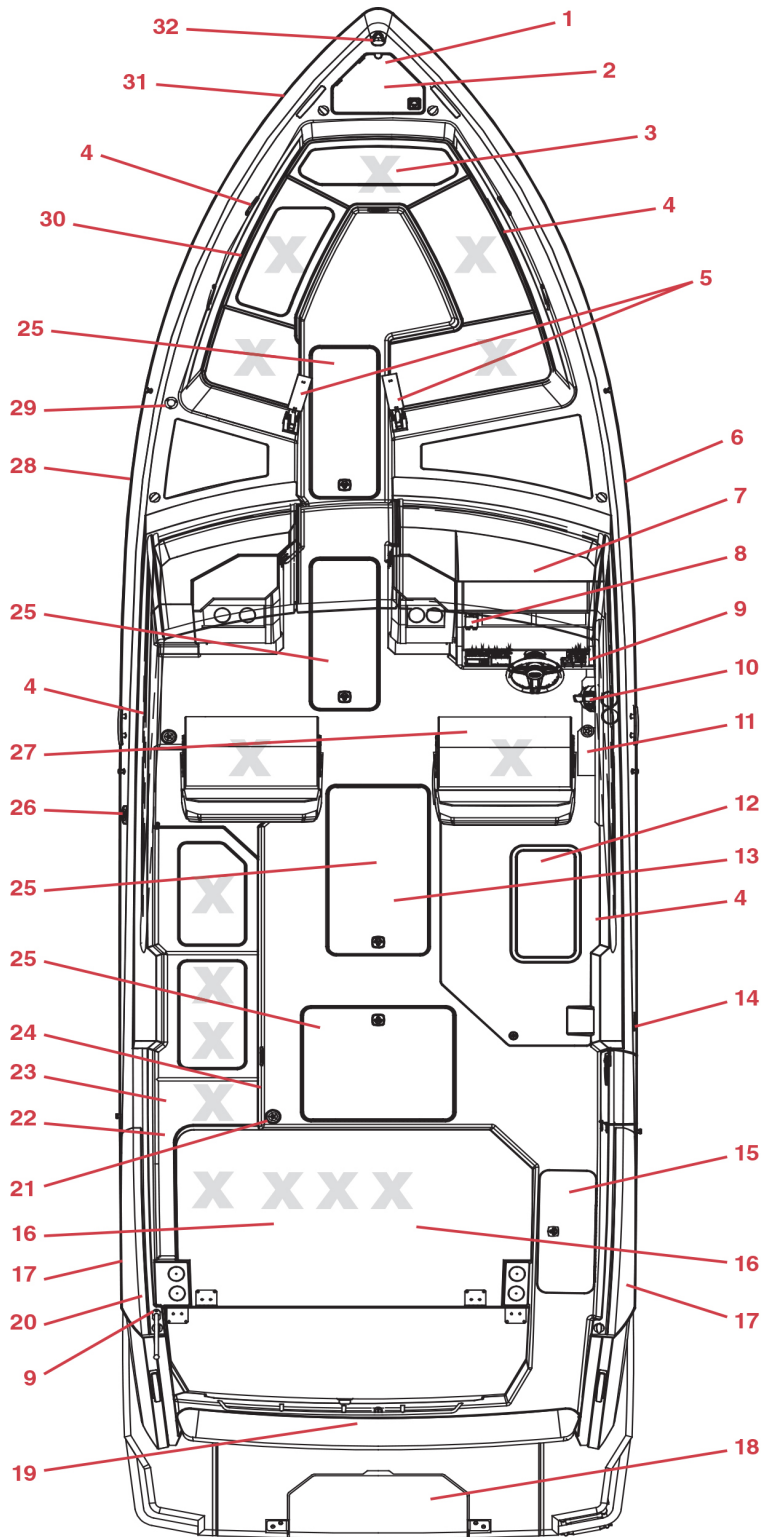

1. Windlass (optional)
2. Anchor Area
3. Ice Chest
4. USB
5. Armrest
6. Cabin Area
7. Helm Area
8. Wireless Phone Charger
9. 12V Outlets
10. Throttle/Shift/Ignition Safety Switch
11. Stereo USB
12. Trash Can/Galley
13. Fuel Access
14. Gas Fill
15. Wet Locker
16. Adjustable Backrest
17. Engine Vent
18. Flip Down Step
19. Ski Tow
20. Stereo Remote
21. Cockpit Drain
22. Battery Board
23. Fire Extinguisher
24. Dinette Table
25. Floor Storage
26. Water Fill
27. Flip Bolster
28. Head Area
29. Waste Ftg
30. Port Storage
31. Docking Light (optional)
32. Bow Navigation Light

COB_0577_A

R33

R33 SPECIFICATIONS

Length Overall w/Swim Platform	33'4"/10.16 m	33'4"/10.16 m
Beam	10'6"/3.20 m	10'6"/3.20 m
Deadrise at Transom	21°	21°
Fuel Capacity	150 gal/568 L	150 gal/568 L
Fresh Water Capacity	25 gal/95L	25 gal/95 L
Bridge Clearance (windshield only)	6'7"/2.00 m	6'7"/2.00 m
Bridge Clearance (tower up)	9'4"/2.84 m	9'4"/2.84 m
Bridge Clearance (tower down)	7'11"/2.41 m	7'11"/2.41 m
Bridge Clearance (w/hardtop & radar)	10'4"/3.15 m	10'4"/3.15 m
Draft, Drive Up, Twin Engine	26"/0.66 m	26"/0.66 m
Draft, Drive Down, Twin Engine	33"/0.84 m	33"/0.84 m
Dry Weight w/Twin Engine (no options)	11,193 lb/5,077 kg	11,793 lb/5,349 kg
Boat Certified Capacity	Yacht Certified	
Boat Certified Capacity w/gear	Yacht Certified	

MERCUISER STERNDRIVE POWER

Twin 6.2L MPI ECT 300 B3DTS Axius	300 hp
Twin 6.2L MPI ECT 350 B3DTS Axius	350 hp
Twin 8.2 Mag ECT B3X DTS Axius	380 hp
Twin 8.2 Mag HO ECT B3X DTS Axius	430 hp

VOLVO PENTA STERNDRIVE POWER

Twin V8 300CE-G DP Joystick	300 hp
Twin V8 350CE-G DP Joystick	350 hp
Twin V8 380CE DP Joystick	380 hp
Twin V8 430CE DP Joystick	430 hp

R33



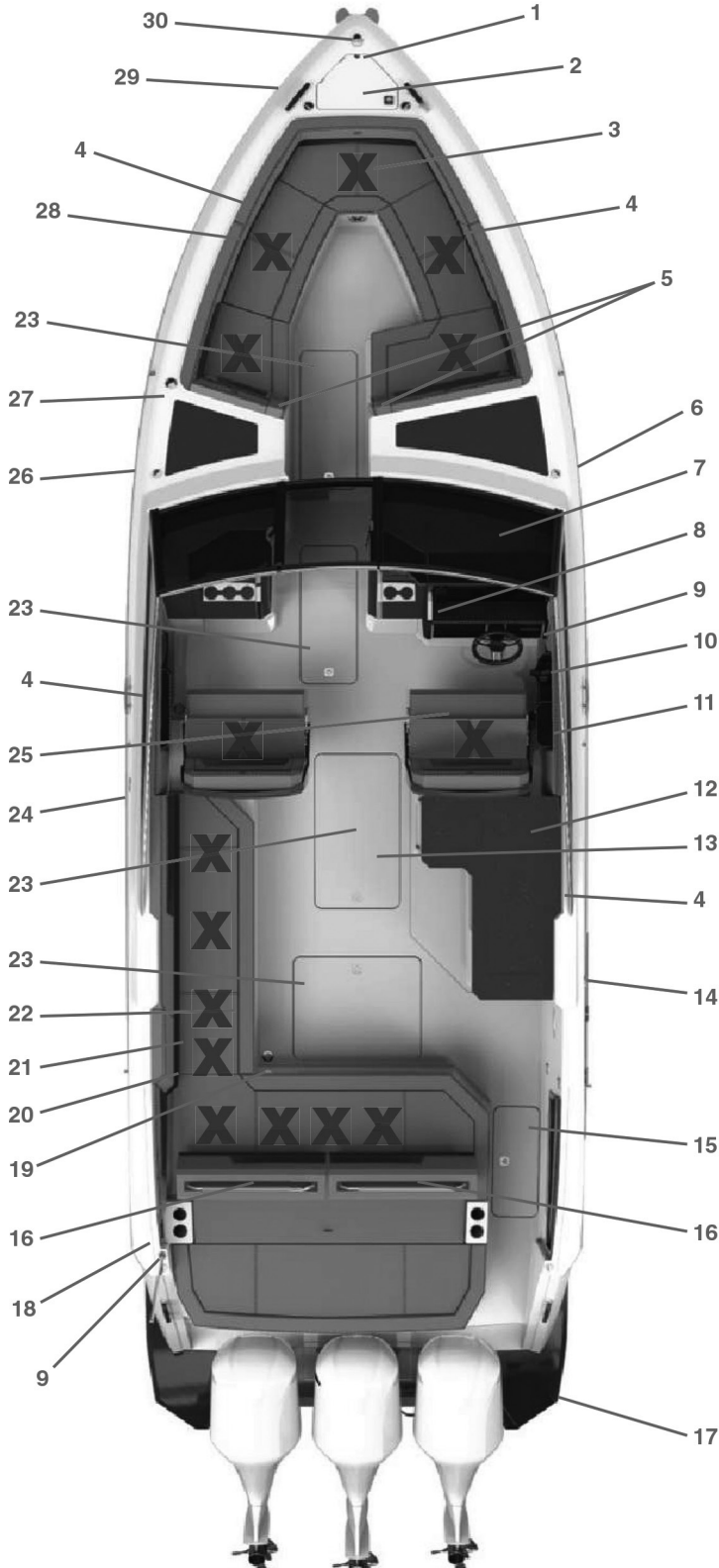

COB_0591_A

1. Windlass (optional)
2. Anchor Area
3. Ice Chest
4. USB
5. Armrest
6. Cabin Area
7. Helm Area
8. Wireless Phone Charger
9. 12V Outlets
10. Throttle/Shift/Ignition Safety Switch
11. Stereo USB
12. Trash Can/Galley
13. Fuel Access
14. Gas Fill
15. Wet Locker
16. Adjustable Backrest
17. Ladder
18. Stereo Remote
19. Cockpit Drain
20. Battery Board
21. Fire Extinguisher
22. Dinette Table
23. Floor Storage
24. Water Fill
25. Flip Bolster
26. Head Area
27. Waste Ftg
28. Port Storage
29. Docking Light (optional)
30. Bow Navigation Light

R33
OUTBOARD

R33 OUTBOARD SPECIFICATIONS

Length Overall w/Swim Platform	33'4"	10.16 m
Beam	10'6"	3.20 m
Deadrise at Transom	21°	21°
Fuel Capacity	225 gal	851 L
Fresh Water Capacity	25 gal	95 L
Bridge Clearance (windshield only)	6'7"	2.00 m
Bridge Clearance (tower up)	9'4"	2.84 m
Bridge Clearance (tower down)	7'11"	2.41 m
Bridge Clearance (w/hardtop & radar)	10'4"	3.15 m
Draft, Drive Up, Twin Engine	21.89"	0.56 m
Draft, Drive Down, Twin Engine	28.47"	0.72 m
Draft Drive Up, Triple Engine	21.89"	0.56 m
Draft Drive Down, Triple Engine	35.6"	0.9 m
Dry Weight w/Twin Engine (no options)	11,193 lb	5,349 kg
Boat Certified Capacity	Yacht Certified	
Boat Certified Capacity w/gear	Yacht Certified	

R33

OUTBOARD

YAMAHA OUTBOARD POWER

Triple F300 XCA, White w/Joystick	300 hp
Twin F300 XCA White w/Joystick	300 hp

MERCURY OUTBOARD POWER

Triple 300 Verado Black or White w/Joystick	300 hp
Twin 300 Verado Black or White w/Joystick	300 hp
Twin 350 Verado V10, Black or White w/Joystick	350 hp
Twin 400 Verado V10, Black or White w/Joystick	400 hp
Twin 450R Verado, Black or White w/Joystick	450 hp



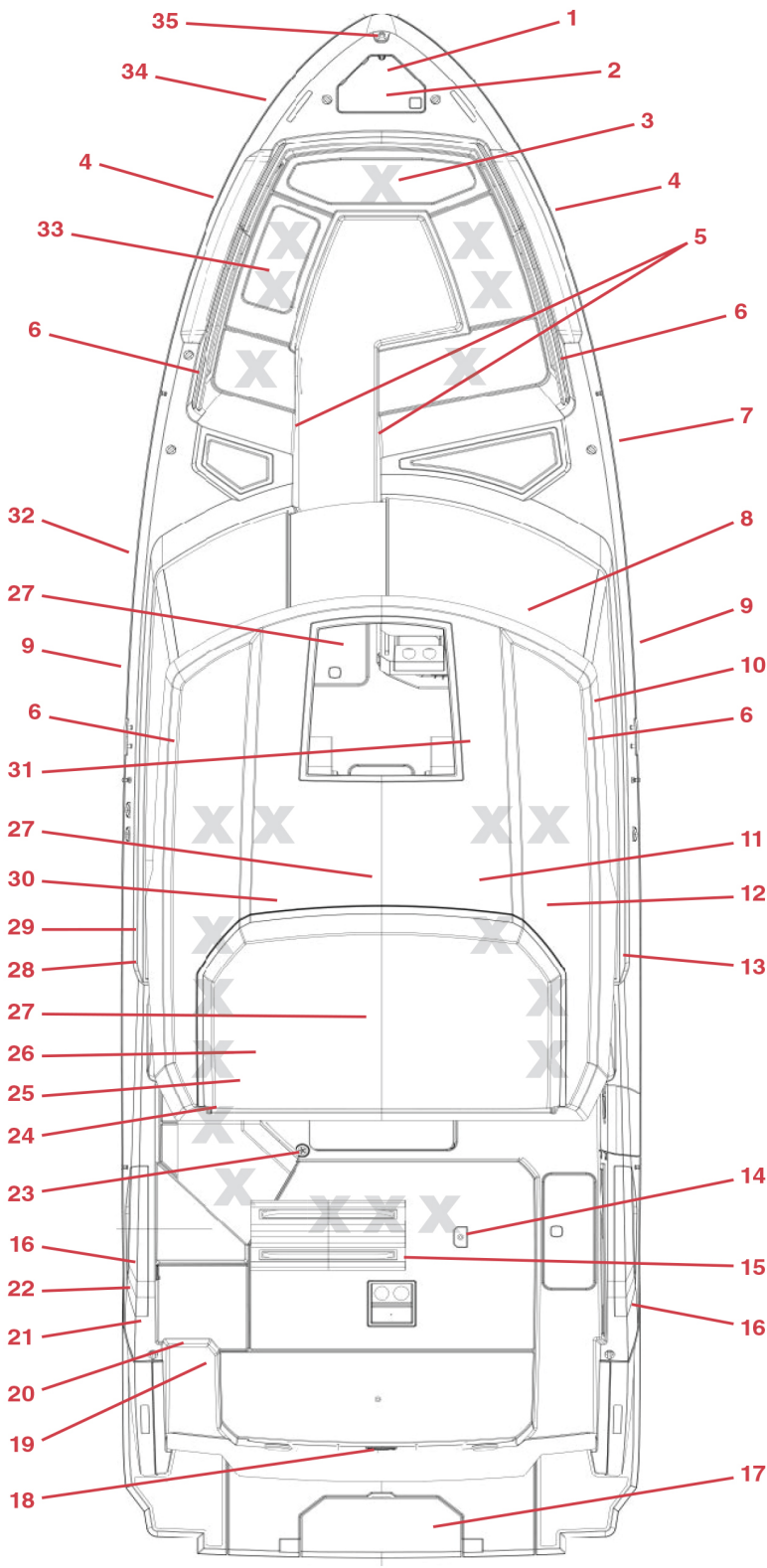

1. Windlass (optional)
2. Anchor Area
3. Ice Chest
4. Wireless Phone Charger (optional)
5. Armrest
6. USB
7. Cabin Area
8. Helm Area
9. Wireless Phone Charger
10. Throttle/Shift/Ignition Safety Switch
11. Trash Can
12. Galley (optional)
13. Gas Fill
14. Wet Locker
15. Adjustable Backrest
16. Engine Vent
17. Flip Down Step
18. Ski Tow
19. Transom Shower
20. Shore Power
21. Dual USB/12V Outlet
22. Stereo Remote
23. Cockpit Drain
24. Battery Board
25. Fire Extinguisher
26. Dinette Table
27. Floor Storage
28. Water Fill
29. Waste Fitting
30. Refrigerator (optional)
31. Flip Bolster
32. Head Area
33. Port Storage
34. Docking Light (optional)
35. Bow Navigation Light

COB_0593_A

R35

R35 SPECIFICATIONS

Length Overall w/Swim Platform	35'4"	10.77 m
Beam	10'10"	3.30 m
Deadrise at Transom	21°	21°
Fuel Capacity	165 gal	625 L
Fresh Water Capacity	10 gal	38 L
Bridge Clearance	9'7"	2.92 m
Bridge Clearance w/radar	10'7"	3.23 m
Bridge Clearance w radar & Flir	11'7"	3.53 m
Draft, Drive Up, Twin Engine	28"	0.71 m
Draft, Drive Down, Twin Engine	38"	0.97 m
Dry Weight w/Twin Engine	13,400 lb	6,078 kg
Boat Certified Capacity	Yacht Certified	
Boat Certified Capacity w/gear	Yacht Certified	

MERCUISER STERNDRIVE POWER

Twin 6.2L MPI ECT 300 B3DTS Axius	300 hp
Twin 6.2L MPI ECT 350 B3DTS Axius	350 hp
Twin 8.2 Mag ECT B3X DTS Axius	380 hp
Twin 8.2 Mag HO ECT B3X DTS Axius	430 hp

VOLVO PENTA STERNDRIVE POWER

Twin V8 300CE-G DP Joystick	300 hp
Twin V8 350CE-G DP Joystick	350 hp
Twin V8 380CE DP Joystick	380 hp
Twin V8 430CE DP Joystick	430 hp

R35



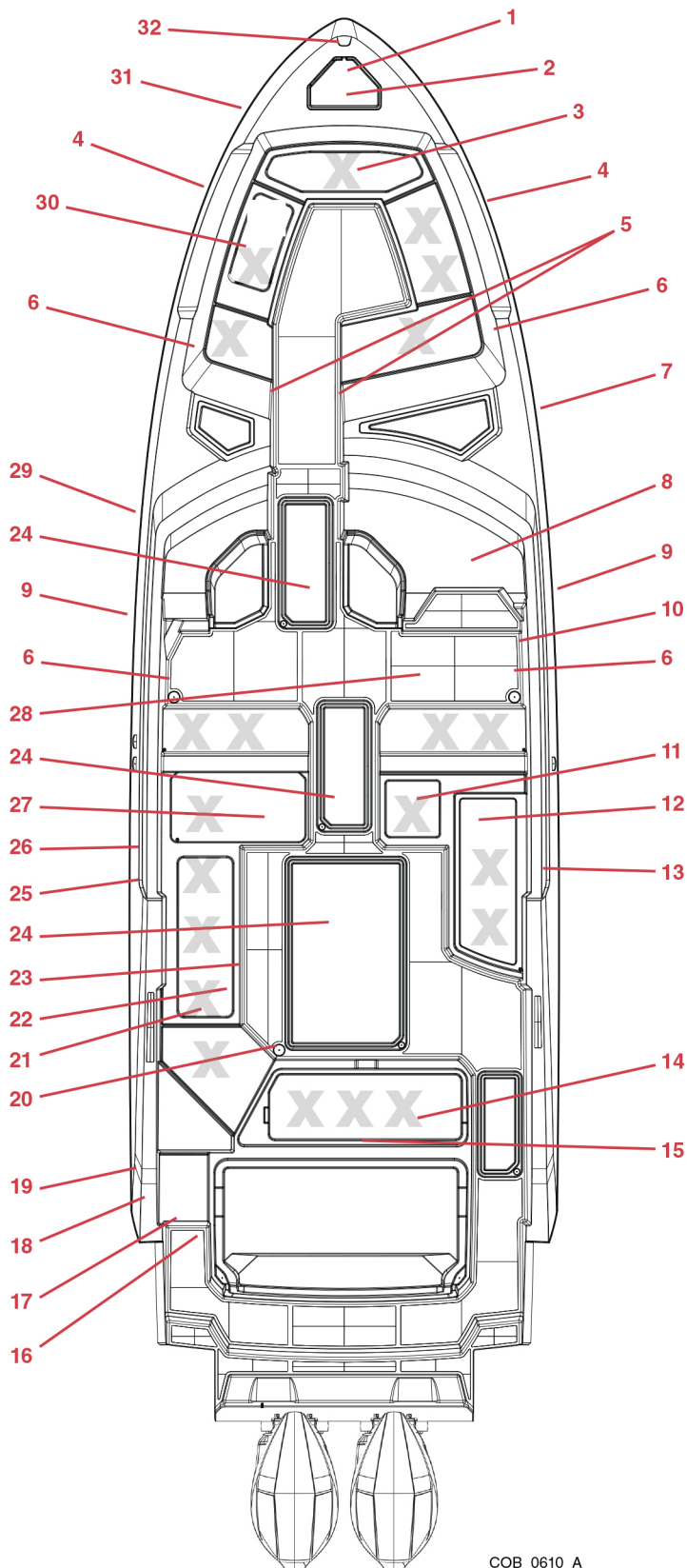

1. Windlass (optional)
2. Anchor Area
3. Ice Chest
4. Wireless Phone Charger (optional)
5. Armrest
6. USB
7. Cabin Area
8. Helm Area
9. Wireless Phone Charger
10. Throttle/Shift/Ignition Safety Switch
11. Trash Can
12. Galley (optional)
13. Gas Fill
14. Wet Locker
15. Adjustable Backrest
16. Transom Shower
17. Shore Power
18. Dual USB/12V Outlet
19. Stereo Remote
20. Cockpit Drain
21. Battery Board
22. Fire Extinguisher
23. Dinette Table
24. Floor Storage
25. Water Fill
26. Waste Fitting
27. Refrigerator (optional)
28. Flip Bolster
29. Head Area
30. Port Storage
31. Docking Light (optional)
32. Bow Navigation Light

COB_0610_A

R35
OUTBOARD

R35 OUTBOARD SPECIFICATIONS

Length Overall w/Swim Platform	35'4"	10.77 m
Beam	10'10"	3.30 m
Deadrise at Transom	21°	21°
Fuel Capacity	250 gal	946 L
Fresh Water Capacity	25 gal	95 L
Holding Tank Capacity	10 gal	38 L
Bridge Clearance	9'7"	2.92 m
Bridge Clearance w/radar	10'7"	3.23 m
Bridge Clearance w radar & Flir	11'7"	3.53 m
Draft, Drive Up, Twin Engine	28"	0.71 m
Draft, Drive Down, Twin Engine	38"	0.97 m
Dry Weight w/Twin Engine	13,400 lb	6,078 kg
Boat Certified Capacity	Yacht Certified	
Boat Certified Capacity w/gear	Yacht Certified	

YAMAHA OUTBOARD POWER

Triple F300 XCA, White w/Joystick	300 hp
Twin F300 XCA White w/Joystick	300 hp

MERCURY OUTBOARD POWER

Triple 300 Verado Black or White w/Joystick	300 hp
Twin 300 Verado Black or White w/Joystick	300 hp
Twin 350 Verado V10, Black or White w/Joystick	350 hp
Twin 400 Verado V10, Black or White w/Joystick	400 hp
Twin 450R Verado, Black or White w/Joystick	450 hp
Twin 600 Verado, Black or White w/Joystick	600 hp



R35

OUTBOARD





Components and Systems

INTRODUCTION

NOTE THAT NOT ALL DESCRIBED COMPONENTS ARE FOUND ON ALL OF THE MODELS DESCRIBED IN THIS OWNER'S MANUAL.

This section provides critical information about the mechanical, electronic, and manual operating systems on Cobalt boats. It describes basic operating characteristics and provides information for efficient use of the equipment and for prevention of casualties. Be sure to read and understand all information provided before operating any of these systems.



WARNING

Regularly inspect and maintain all systems to prevent unexpected hazards associated with worn or faulty components. Be sure to replace system components and hardware with marine-grade parts, not automotive components. Additional care and maintenance information follows in this owner's manual.

ROUTING

The following information is provided to assist new boat owners with the orientation of support systems within the boat. Consumers should **NEVER** attempt to make any repairs to these systems. If repairs are required, they should be undertaken **ONLY** by authorized Cobalt service technicians.

Lower left: A29 Bilge

Below right: A29 Fueling
Lower right: A29 Plumbing

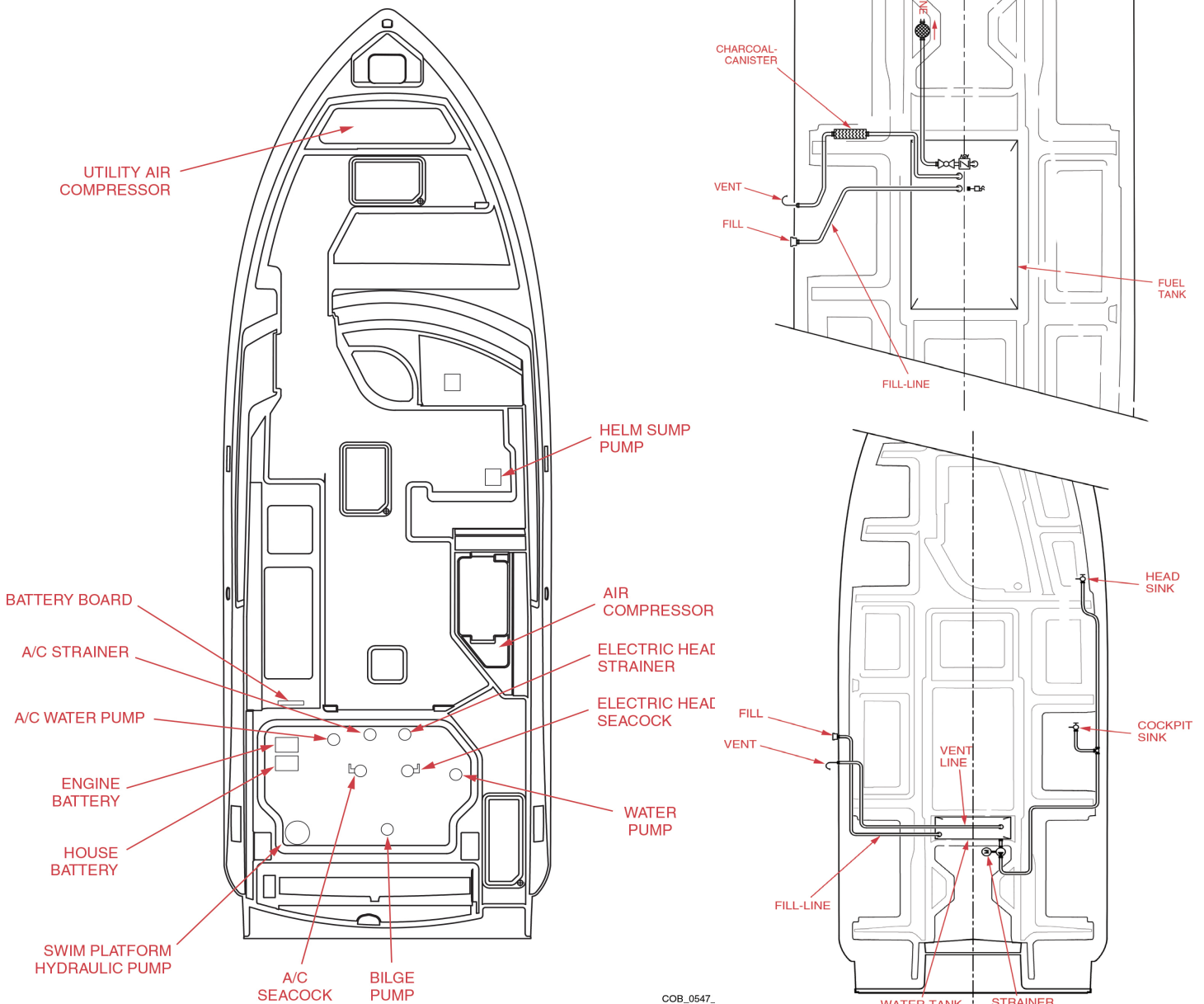

COB_0547_

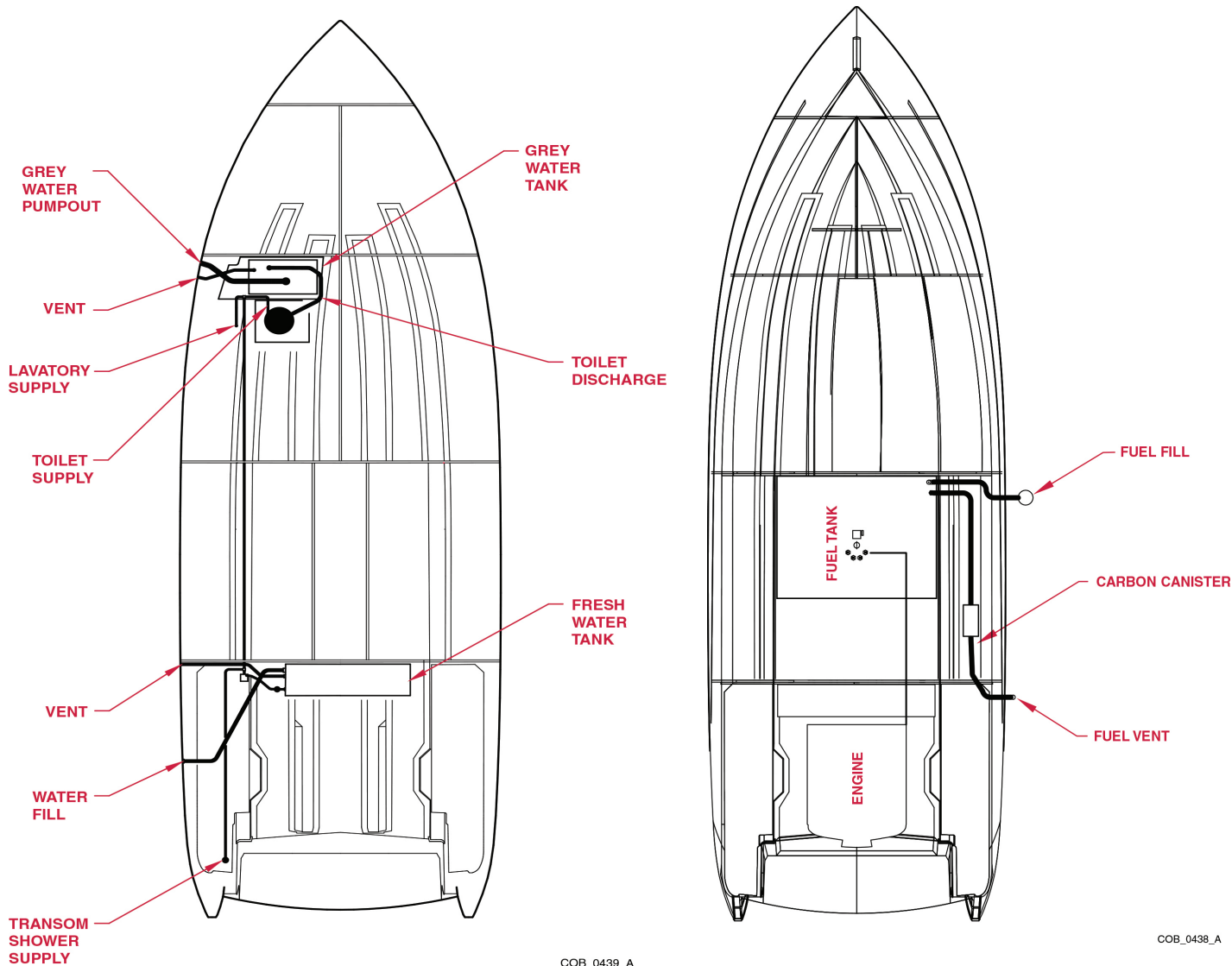

Upper Left: R30, R35 Plumbing
 Upper Right: R30, R35 Fuel
 Below: Vacu-Flush

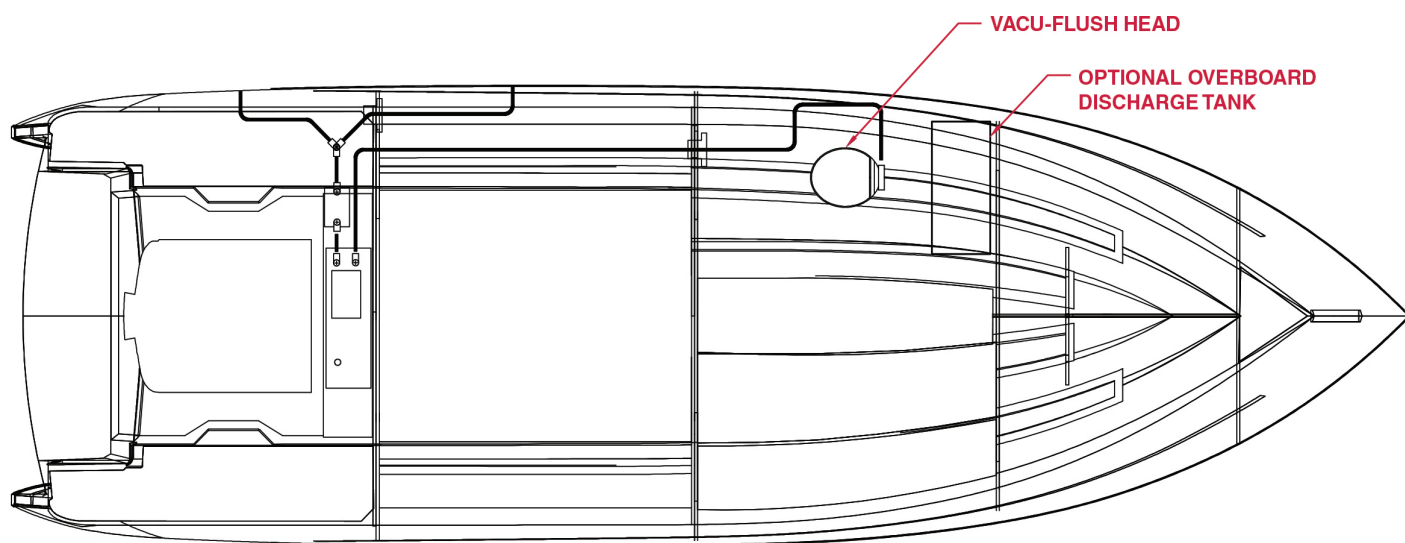

FIRE SUPPRESSION EQUIPMENT

Even when surrounded by water, fire is a significant concern. In fact, because safe egress from the boat is limited if it becomes necessary to abandon ship, this issue reinforces the need for easily accessible PFDs.

When boating in the United States, boats of less than 26 feet in length are required to have at least one B1-rated, hand-held fire extinguisher onboard and fully charged, unless there is an automatic fire extinguishing system installed.

An automatic system is available as an option on Cobalt boats. **Hand-held units are included in standard equipment but consumers can choose from a wide range of fire extinguishers on the market, many of which exceed the minimum requirements. If the boat does not have an automatic fire extinguishing system installed, the boat owner MUST purchase and install at least one B1-rated fire extinguisher.**

Most countries have fire extinguishing and suppression requirements for recreational boats. It is the responsibility of the boat owner and/or operator to determine the requirements for the body of water on which the boating will occur. To avoid citations and/or arrest, boaters should check with local governmental agencies regarding specific requirements and limitations for boating on the applicable body of water.

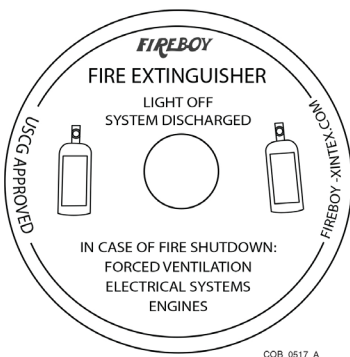

If your Cobalt boat is equipped with a fixed automatic fire extinguisher that uses Clean Agent HFC-227ea as an extinguishing agent, it is mounted in the engine compartment and generator compartment (if equipped). These extinguishers are activated when the heat-sensitive head reaches a predetermined temperature.

The extinguisher discharges and saturates the engine and/or generator compartment, smothering the fire.



Whenever fire extinguishers or suppression units have been used in fighting an onboard fire, a careful determination should be made whether it is safe to operate the boat. In most instances, it is advisable to have the boat towed to shore rather than risk additional fire or permanent damage to the drivetrain. The boat should be thoroughly serviced by an authorized Cobalt dealer prior to operation again. Operation prior to service could result in additional damage to the boat and may result in serious injury or death.



DO NOT open the engine compartment hatch immediately. This will allow oxygen to reach the fire, and flashback can occur. When the fire extinguisher discharge occurs, turn off all engine(s), bilge blowers and electrical system components.

Following discharge of fire suppression material, the system will require recharging. If an automatic system has discharged, it is unlikely that the boat can be run. Cobalt recommends getting a tow to shore and having the engine compartment thoroughly cleaned and the fire suppression system recharged prior to running the boat's engine again. If hand-held units have been discharged, these will also require recharging. The chemicals in all fire suppression units can discolor upholstery and carpeting.

It is recommended that the boat be cleaned as soon as practical. The fire suppression manufacturers provide information regarding the proper and appropriate cleaning agents. Also, pay attention to the cleaning instructions provided in the *Interior/Exterior Care and Maintenance* section of this manual to avoid permanent damage to materials.

Even if systems are not discharged, fire extinguishers and suppression units require periodic maintenance. For a factory-installed automatic fire suppression system, a check of the system should be part of the routine annual maintenance. Hand-held units should be examined regularly for rust, corrosion, damage, or leakage. Weigh the unit annually to be certain that it meets the minimum listed on the label. If it has been used, even partially, it should be recharged by a qualified fire-extinguisher servicing company.

When purchasing fire extinguishing and suppression units, Cobalt strongly recommends buying units that are prepared specifically for the marine environment. The standards for these units have been established by the U.S. Coast Guard and the American Boat and Yacht Council (ABYC). In other countries, follow the recommendations and requirements of local jurisdictions and boating authorities.

Cobalt recommends fire extinguishing and suppression units and systems that exceed the minimum requirements. While an automatic fire suppression system is highly effective in most instances of an engine compartment fire, it is possible that a fire could occur in another area of the boat. **Therefore, Cobalt recommends always having at least one hand-held unit fully charged and onboard, even if the boat is equipped with a suppression unit.**



Fire Extinguisher Manual Pull

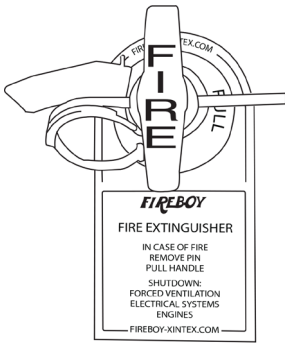

In case of fire in the engine compartment (where equipped), shut off all engines and blowers. Do not open the motor box. Where equipped, pull the handle(s) to the fixed fire extinguisher system located at the helm to discharge extinguishing agent into the engine compartment.



Fire Port

In case of fire on the vessel that may involve electrical components or wiring, and boat operations are not required, turn off all battery switches. Use the fire extinguisher(s) or fire extinguishing agents as appropriate.

In case of fire in boats built with an engine compartment, shut off all engines and blowers. Do not open the motor

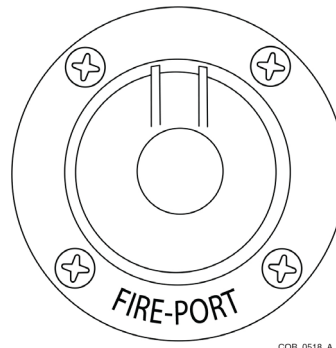

box. If applicable, pull the handle(s) to the fixed fire extinguisher system located at the helm to discharge extinguishing agent into the engine compartment(s).

Or, if applicable, locate the fire port opening on the motor box and fully discharge properly sized flooding, clean agent fire extinguisher

into the compartment.

NOTE: There may be more than one fixed system if a generator is installed.

Small portable fire extinguishers are for small fires as noted above and may not be the proper size or agent for flooding the engine and/or generator compartment.

Refer to an authorized Cobalt dealer for more information and assistance.

ELECTRICAL SYSTEM

DC Electrical

The Cobalt boat has a 12-volt DC system with a negative ground. The positive wire supplies the electrical charge and feeds current from the batteries to all 12-volt equipment; the negative wire is the ground.

The DC components are:

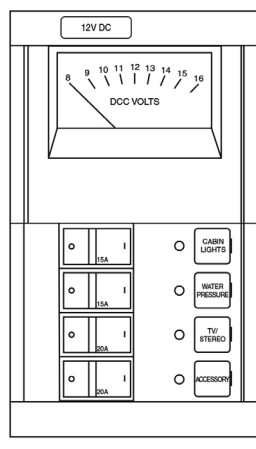

COB_0352_f

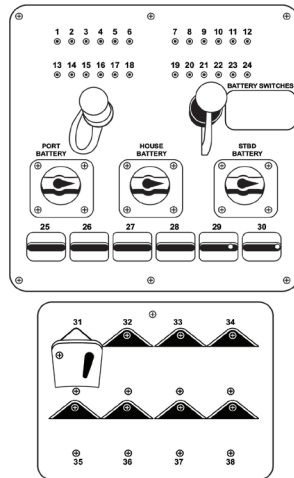

COB_0383_A

Left: R35 DC electrical panel . Right: R33 DC electrical panel & breakers. See Load List under Circuit Breaker Panel information.

controlled from the helm switches. If your Cobalt boat has a cabin, it may have an electrical system panel that supplies 12 volts to these types of accessories:

- Cabin lights
- Cockpit lights
- Head
- Fresh water pressure pump
- Air compressor
- Entertainment system



The DC cabin distribution panel is labeled:

- DC Voltmeter
- Cabin lights
- TV/Stereo
- Accessory

There are also four (4) indicator lights, one for each switch. (See Cabin Distribution Panel information that follows, for more information.)

The 12V DC system consists of a voltmeter, a main circuit breaker and a series of switch-type circuit breakers. The voltmeter is a check on the condition of the batteries. (See *additional information under Battery Switches in this chapter.*)

An authorized Cobalt dealer can assist in determining the type and extent of the boat's electrical system.

Due to the complexity of the boat's wiring, much of which is inaccessible inside the hull and under the deck, any time an issue is suspected involving the wiring or any of the harnesses, the boat owner is strongly encouraged to have the boat serviced by an authorized Cobalt dealer.



Electrical wiring or harness issues should always be addressed by an authorized Cobalt dealer. Alteration of wiring from the original Cobalt design could result in shock hazard, potential spark that could lead to fire, or other danger situations. Any disruption of the wiring from its original plan and resultant damage to components or the boat is not covered under warranty. Individuals could also be injured by such error.

AC Electrical

When the shore power cord is plugged in, all AC equipment can be operated. The shore power cord supplies power to the breakers.

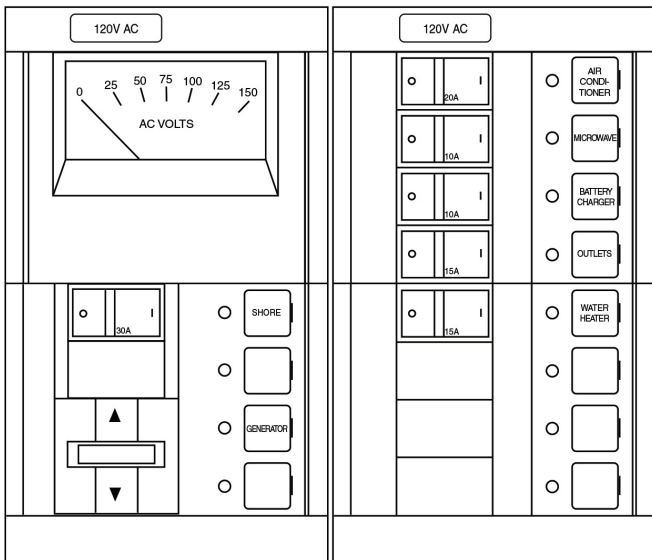

Above: R35 AC electrical panel.
Left: R33 AC electrical panel.

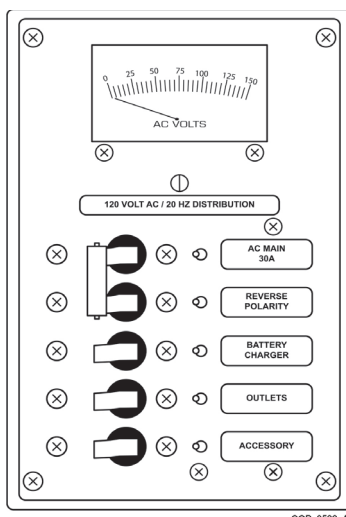

The AC cabin distribution panel is labeled as follows:

- AC Voltmeter
- Shore
- Generator
- Air Conditioner
- Microwave
- Battery Charger
- Outlets
- Water Heater



Shore Power Connection



- Plugs and receptacles for different systems are designed in non-interchangeable configurations.
- A plug from one system cannot fit another system.
- DO NOT modify a shore power cable.
- Use only commercially available adapters for system modification.
- Ventilate the boat interior by opening the deck hatches, windows and cabin door to provide adequate ventilation.

The shore power system requires a special, marine-grade three-conductor cable to make a proper connection to the shore. Dockside connections and the boat-side connections

are plug-in. Boat-side connections are also locked in position with a threaded locking collar to prevent accidental disconnection and enhance water resistance. The shore power connection is located at the port aft of the boat. Make sure the shore power connection cover is in place when the shore power connection is not in use.

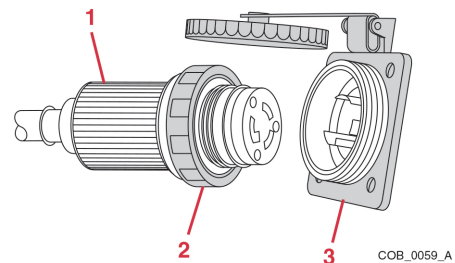

- 1 – Shore Power Cord
- 2 – Threaded Locking Collar
- 3 – Boat Receptacle

Above: R35 shore power connector.
Below: R33 shore power connector.

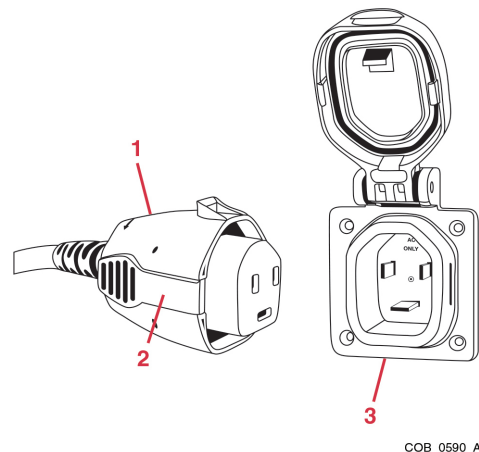

- 1 – Shore Power Cord
- 2 – Self-Locking Side Clip
- 3 – Boat Receptacle

To connect:

1. Turn OFF the boat's MAIN AC circuit breaker on the Cabin Distribution Panel.
2. If the outlet on the pier has a disconnect switch, turn the switch OFF.
3. Connect the shore power cable at the boat side first.
4. Be sure the cable has more slack than the mooring lines!
5. Remove the cap from the outlet on the pier.
6. Connect the cable to the outlet.
7. If the boat is equipped with an optional generator, turn the SHORE/GENERATOR switch to the SHORE position.
8. Turn the inlet breaker ON. It is located in the port aft sundeck storage.
9. Set the shore disconnect switch to the ON position.

To disconnect:

NOTICE

If the boat is equipped with an optional generator and wish to keep the AC appliances operating while underway, start the generator and turn the selector switch to **GENERATOR** and skip Step 1 that follows. **DO NOT** use the generator above speeds over 40 MPH (64 KM).

1. Turn **OFF** the boat's main circuit breakers.
2. If the shore outlet has a disconnect switch, turn it to the **OFF** position.
3. Disconnect the shore power cord at the shore outlet.
4. Disconnect the cable from the boat and close the cap.

⚠ DANGER

Some marinas have been known to “break” shore power ground circuits to prevent electrolysis. Opening the ground circuit creates a potentially dangerous on board shock hazard. Use caution when using a “break” shore power ground circuit. If the reverse polarity light is activated, immediately disconnect shore power cable.

NOTICE

Avoid damage to the electrical system and components; **DO NOT** use AC-powered equipment if voltage is less than 105 volts.

The Cobalt boat is equipped with an isolation transformer which isolates shore power from the boat's AC electrical system, reducing galvanic corrosion and the risk of electrical shock. For more information refer to the component manual supplied in the owner's packet or see an authorized Cobalt dealer regarding the shore power system.

The AC portion of the distribution panel receives AC power from the shore power cable or optional generator. The panel distributes AC power through main circuit breaker(s), which in turn supplies the circuit breakers.

AC electricity operates the equipment displayed on the AC cabin distribution panel.

The 110V AC system consists of inlet breakers, a shore/generator selector switch located at the distribution panel in the cabin, which contains a voltmeter, main circuit breaker and a series of switch-type circuit breakers.

The voltmeter monitors the AC voltage. Damage can occur to the equipment if the voltage is less than 105 volts. **DO NOT** use AC-powered equipment if voltage is less than 105 volts.

The main circuit breaker switch controls the individual component circuit breakers below it. This allows for a check for proper voltage and polarity immediately after making the shore power cable connection without damaging any equipment.

The reversed polarity light indicates if the polarity of the shore power has been reversed.



Shore Power Inlet Breaker Switch

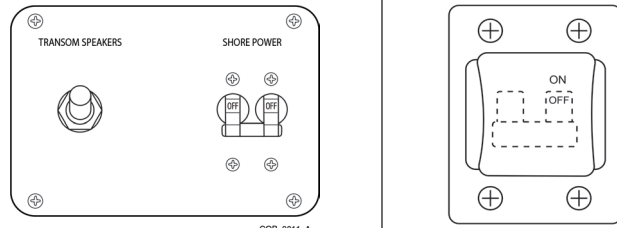

Above left: R35 shore power inlet breaker switch.
Above right: R33 shore power inlet breaker switch.

The shore power inlet breaker switch is located aft port side. This controls 110V AC components.



Circuit Breaker Panel

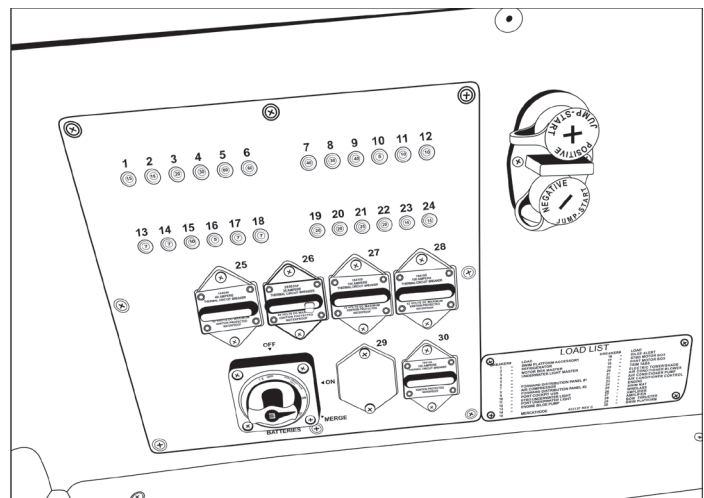

LOAD LIST			
BREAKER #	LOAD	BREAKER#	LOAD
1	- SWIM PLATFORM ACCESSORY	16	- BILGE ALERT
2	- REFRIGERATOR	17	- STBD MOTOR BOX
3	- MOTOR BOX MASTER	18	- PORT MOTOR BOX
4	- UNDERWATER LIGHT MASTER	19	- TRIM TABS
5	-	20	- ELECTRIC TOWER/SHADE
6	-	21	- AIR CONDITIONER BLOWER
7	- FORWARD DISTRIBUTION PANEL #1	22	- AIR CONDITIONER PUMP
8	- AIR COMPRESSOR	23	- AIR CONDITIONER CONTROL
9	- FORWARD DISTRIBUTION PANEL #2	24	- ENGINE
10	- PORT COCKPIT USB	25	- SWIM MAT
11	- STBD UNDERWATER LIGHT	26	- WINDLASS
12	- PORT UNDERWATER LIGHT	27	- AMPLIFIER
13	- ENGINE BILGE PUMP	28	- AMPLIFIER
14	-	29	- BOW THRUSTER
15	- MERCATHODE	30	- SWIM PLATFORM

Above: A29 panel and Load List.

Many features on your Cobalt boat are controlled by electrical current. To protect persons onboard and boat features, the current may be interrupted by circuit breakers. These breakers prevent damaging electrical surges or overloads on the entire system.

Most electrical standard equipment devices are controlled with circuit breakers located in the starboard bow storage compartment.

When a circuit breaker senses an overload or some other issue (such as water intrusion) that places operation in jeopardy,

the breaker will activate, or “pop.” If the cause is relatively minor, power can quickly be restored to that particular circuit by pressing on the circuit button. Which circuit is affected should be obvious when looking at the breaker box in the starboard bow storage compartment as it will not align with the other circuit breakers’ positions. Clear the fault before resetting the breaker. In the event the fault cannot be cleared, contact your Cobalt dealer immediately before resetting.

The breakers are labeled to identify the device protected. These breakers will activate if overloaded and cut power to the switch. To restore power, turn off the device, push the breaker button in and release. If the button continues to pop out when the device is used, see your authorized Cobalt dealer.



Cabin Distribution Panels



- Use the electrical system properly.
- Do not work on an energized system.
- Avoid swimming near the boat when it is connected to shore power.
- Use caution when connecting or disconnecting to shore power.
- Do not reset a circuit breaker which has been automatically tripped, without first detecting and correcting the cause of the problem.
- Turn the boat’s shore connection switch to the OFF position before connecting or disconnecting the shore cable.
- Connect the shore power cable at the boat first.
- Disconnect the shore power cable at the shore outlet first.
- If the reverse polarity light is activated, IMMEDIATELY disconnect the shore power cable.
- Do not alter the shore power cable connections.
- Close the shore power inlet cover tightly.

Cobalt boats may be equipped with two electrical systems: a battery-powered direct current (DC) system, and a shore-powered alternating current (AC) system. An optional generator can provide AC current when away from shore power. These systems have a load center panel, which serves as the main distribution panel.

The DC system supplies electricity to all of the boat’s electrical circuits (lights, pumps, blowers, ignition, etc.)

The AC system supplies electricity to all of the boat’s AC-powered electrical circuits (electrical outlets and to AC-powered systems) when the boat is moored or moored to a dock or slip.

Some options may be equipped with multiple batteries. There is a cranking battery for each engine and a house battery.

There is a battery charger for the house and cranking

batteries. The battery chargers are powered by either the dockside or generator 120V AC power.

All batteries are isolated from each other by a battery switch. (See *additional important battery switch information later in this chapter of the owner’s manual.*) When the engines and ignition switches are OFF, the isolator prevents the house battery loads from discharging the cranking batteries. When the batteries are being charged by the alternators, the isolator automatically isolates the batteries and will distribute the charge among the batteries according to individual need.

Main Electrical Panel

The main electrical panel is located in the cabin behind the aft seat back cushion. This controls both 110V AC and 12V DC components.



Fuses

Some accessories or electrical components have in-line fuses in them. Check the failed component for the possibility of an in-line fuse if a tripped circuit breaker is not found. (Some of these accessories or electrical components may not be included or available on your boat.)

Unlike circuit breakers which will reset, fuses must be replaced. They will be marked as to size. Replace only with the size specified. Any other could result in damage to the system or to other components. Boat owners are encouraged to keep a supply of replacement fuses in an enclosed, waterproof container onboard at all times.



Battery Connections



Avoid the potential of explosion from shorting or arcing. Keep the battery connections tight and clean, the terminal covers in place and the battery(ies) secure in the restraint system.

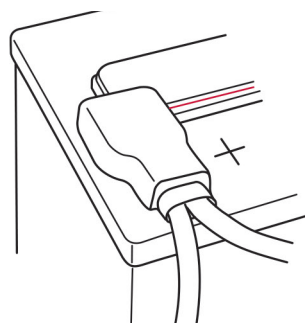

Loose battery connections can cause errant signals to the boat’s electrical system. Read and understand the safety information on or supplied with your battery(ies). Maintain the battery(ies) following the manufacturer’s recommendations.

Use marine-rated batteries only!

Never use automotive batteries as they do not have the additional protection necessary to function in a boat where water and humidity are always factors.

⚠ DANGER

If it becomes necessary to recharge a battery from an external source, **DO NOT** attempt to charge using automotive battery cables or use another boat battery as the source for charging. Some amounts of hydrogen gas are emitted during the charging process. This can be very dangerous. It is critical to keep all sparks, including lit cigarettes, lighters, or any type of flame, well away from a charging battery. Use the optional battery charger sold by authorized dealers, or a similar aftermarket battery charger. Using the wrong type of charging procedure or improperly charging a battery can result in an explosion and/or fire that could lead to serious injury or death.

⚠ WARNING

Inside the battery is an electrolyte fluid that allows the chemical reaction to provide power. The fluid is comprised of several components, one of which is sulfuric acid. As with most acids, this is caustic and corrosive. If the acid comes in contact with skin, immediately flush the area with copious amounts of fresh, clean water. Follow up with medical assistance.

Batteries used in tandem must always use the same chemistry! Mixing battery types can cause damage to the electrical system, which is not covered under warranty.

⚠ CAUTION

Failure to use marine-rated batteries in your boat could result in electrical system interruptions that could strand your boat during an outing. It is possible for water and the high humidity associated with operation on the water to affect batteries. If a battery, even marine-rated, becomes wet, allow it to dry before trying to start the engine. Water can cause a shortage at the battery terminals, which would prevent operation. Damage to other components due to the use of inappropriate batteries or failure to properly maintain batteries is not covered under warranty.

Connecting/Disconnecting Batteries

The posts on a battery are marked negative (-) and positive (+), one of each on top and separate by some space. The battery cables are color-coded, black for negative and red for positive.

Cobalt recommends having your authorized Cobalt dealer install the batteries. Consumers can perform this procedure, provided common sense safety guides the process.

If batteries have not been previously installed:

Step 1: Ensure the engine is **OFF**, and the battery switch is **OFF** on boats so equipped.

Step 2: Place the batteries in the containers.

Step 3: Attach the positive cable to the secondary (2) battery, attaching the positive (+) cable to the positive (+) post.

Step 4: Attach the positive cable to the primary (1) battery,

attaching the positive (+) cable to the positive (+) positive.
Step 5: Attach the negative (-) cable to the secondary (2) battery, attaching the negative (-) cable to the negative (-) post.

Step 6: Attach the negative (-) cable to the primary (1) battery, attaching the negative (-) cable to the negative (-) post.

Step 7: Check that all cables are secure. **DO NOT** torque any connections; hand-tighten securely using a wrench.

Never round off any of the nuts used to secure the cables. If a nut will not tighten, do not force it. Seek assistance to determine if the nut is the wrong size or some other issue exists.

If a battery requires replacement, reverse the steps above. Never replace a battery with the boat electrical system **ON**. Even if only one battery requires replacement, follow the steps and disconnect/then reconnect cables as directed above.

⚠ DANGER

Never touch positive (+) and negative (-) posts or connections simultaneously during installation! Never attempt to install or replace batteries with the boat electrical system ON, or in the presence of gas fumes. An electrical spark caused by connection to a functional battery can cause an explosion or fire, which is likely to cause serious injury or even death. This can also cause substantial damage to the electrical system, which is not covered under warranty.



Jump-Start Studs

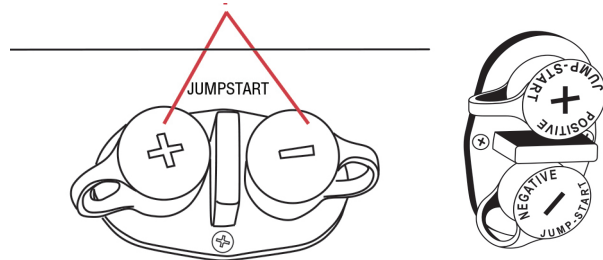

This receptacle allows for jump-starting an engine. The receptacles have protective covers and must stay in place when the receptacles are not being used. The covers identify the + positive (red) and the - negative (black).

The studs can also be used to raise or lower the motor box when the batteries are low or removed. Use an auxiliary battery source such as a battery pack, jumper cables, battery charge, boost battery, etc. See the information in the *Motor Box Assembly* information.

NOTICE

DO NOT start an engine from the jump-start studs without the batteries being connected to the boat's charging system. Damage to the engine and charging system will result.

NOTICE

Connect the auxiliary power source, then turn the battery switches to the ON position. On some models, the battery switches may need to be turned to the COMBINE position.

! DANGER

If it becomes necessary to re-charge a battery from an external source, **DO NOT** attempt to charge using automotive battery cables or use another boat battery as the source for charging. Some amounts of hydrogen gas are emitted during the charging process. This can be very dangerous. It is critical to keep all sparks, including smoking cigarettes, lighters, or any type of flame, well away from a charging battery. Use an optional battery charger sold by authorized Cobalt dealers, or a similar aftermarket battery charger. Using the wrong type of charging procedure or improperly charging a battery can result in an explosion and/or fire that could lead to serious injury or death.



R30 Battery Switches

The dual battery switch provides isolation and positive disconnect from the batteries to protect against tampering, electrical fire hazards and battery rundown. *The switches are located on the battery board in the port aft floor storage.* The battery switch board will vary depending upon the number and type of engine.

NOTICE

The **HOUSE**, **PORT** and **STARBOARD** battery switches must be turned **ON** before starting the engines. These switches must remain **ON** during normal operation.

The switch should normally be in the **ON** position rather than the **COMBINE BATTERIES** position. In the **OFF** position, the boat will be isolated from the batteries except for the items requiring constant power such as the bilge pump.

NOTICE

COMBINE BATTERIES position should be used only for emergency start.

NOTICE

On dual battery installations, there is an Automatic Charging Relay (ACR) installed that allows the engine to charge the house battery. The ACR is intended to keep a load from discharging both of the batteries.

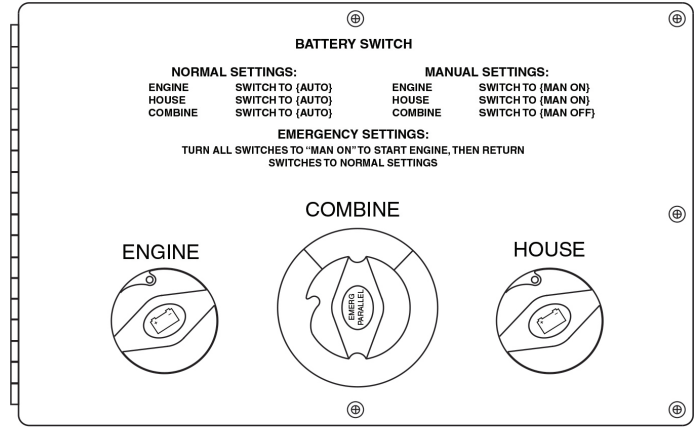

COB_0441_A

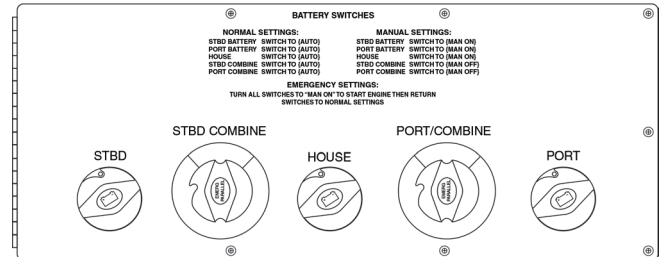

COB_0442_A

Above: R30 battery switches. Below left: R30 remote battery switches. Below right: A29, R33 and R35 battery switch.

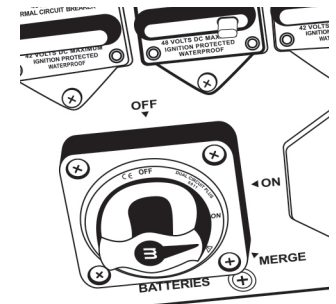
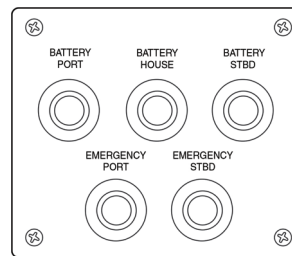

R30 Remote Battery Switches

The individual batteries can be turned **ON** and **OFF** from the helm. The main battery switches in the port aft storage must be turned to **AUTO** to use the remote helm battery switches.

Press the switch once and wait five (5) seconds for the switches to turn **ON** or **OFF**. There is a few seconds of delay, and the light will flash while the switches are turning **ON**.

The helm battery switches will flash anytime the switch is in manual override mode. This alerts the operator that the switches are not operable from the helm.

The emergency port and starboard switches are used to combine the batteries to get more cranking power for starting. Press once to combine the respective battery to the main battery. The batteries will stay combined for ten (10) minutes and then automatically disconnect. Press and hold the switch for five (5) seconds to turn off if needed.

Manual Operation:

If the remote switches fail to operate, the switches can be operated manually. To prevent damage, it is important to press in the ON switch when rotating to a desired position. Turn to Manual OFF and then AUTO to resume the remote operation.

For more information, refer to the battery switch owner's manual.

NOTICE

The HOUSE, PORT and STARBOARD battery switches must be turned ON before starting the engines. These switches must remain ON during normal operation.



A29, R33 and R35 Battery Switch

The battery switches provide isolation and positive disconnect from the batteries to protect against tampering, electrical fire hazards and battery rundown.

A29 & R33:

The starboard, port and House battery switches should be in the ON position. It is possible to operate the boat with the switch in the MERGE position, but this is not recommended for extended periods. In the OFF position, the boat will be isolated from the batteries, except for the automatic bilge pump.

R35:

The starboard switch should be in the "1" position, the port switch should be in the "2" position, and the HOUSE/GEN switch should be in the "2" position.

The boat can be operated with the switch in the "1&2" position, but this is not recommended for extended periods. In the OFF position, the boat will be isolated from the batteries except for the automatic bilge pump.

All:

The starboard battery is dedicated mainly to starting the starboard engine. The port battery is dedicated mainly to starting the port engine. The house battery is dedicated to powering the majority of the boat's electrical systems. If all switches are in the "1&2" position, the batteries combine together essentially forming one larger battery. If a failure should occur with the electrical system or any battery in this configuration, all batteries will end up discharged.

NOTICE

The ACR will allow the port engine to charge the house battery.

Battery Switches/Windlass Breaker: The battery switches/windlass breaker are located under the cockpit port aft seat cushion.



All Models: Automatic Charging Relay (ACR)

On boats equipped with two batteries, the automatic charging relay (ACR) automatically combines the batteries when the engine is running. It also isolates the batteries when discharging to prevent the starting battery from then discharging while using the house battery when the engine is off. The ACR has the following features:

- 120-amp continuous rating
- 12/24V DC auto ranging voltage input
- Senses charging on two battery banks
- Side and bottom knockouts for cable connections
- Clip-on cover insulates terminal connections
- Integrated LED indicates ACR status
- Waterproof-rated IP67 for temporary immersion



Battery Charger—Optional

See specific operating instructions located in the boat new owner's packet or consult your Cobalt dealer for further information. **DO NOT** use any battery charger not specified by Cobalt for use on Cobalt boats. Some chargers are not intended for use in marine environment and can result in shock hazard. Other chargers may not provide sufficient boost. Never use an automotive battery charger or attempt to "jump" the boat's batteries as can be done with land vehicles.

The R33 may be equipped with an optional multi-bank automatic battery charging and isolation system. The batteries are automatically charged when the engines are running or when connected to shore power and the respective power source is selected, and the battery charger breaker/accessory breaker on the panel is ON.

The battery charger system circuit breakers are located on the battery board in the aft port cockpit storage area. Anytime the boat is connected to shore power and the inlet breaker, MAIN, Battery Charger and Accessory switches at the cabin distribution panel are ON, the battery chargers will operate to keep the batteries fully charged.

The battery charging system incorporates an Auto Charging Relay (ACR) system. The ACR system allows the port and starboard engine alternators to charge the House battery banks during normal engine operation and protects the starting batteries from discharging when the engines are OFF.



Generator—Optional



- Read the Safety section of this owner's manual, with particular attention to carbon monoxide concerns.
- Ventilate the boat interior by opening the deck hatches,

- windows and cabin door to provide adequate ventilation.
- **DO NOT** operate the engines or generator with the canvas installed and in use.
- Avoid idling or using the generator while at idle for extended periods.
- Regularly inspect the engine and generator exhaust system for proper operation.
- Operate the blower for at least four (4) minutes each time the engine(s) or generator are started.
- Use the electrical system properly.
- If the reverse polarity light is activated, immediately disconnect the shore power cable.

The optional generator is located in the engine compartment. The generator is used to provide AC power when shore power is not available. The generator uses fuel from the engine's fuel tank and, as a result, produces carbon monoxide (CO).

A controller mounted on the generator contains a start-and-stop switch, hour meter, and a main output AC circuit breaker.

Prior to operation read the instructions and information provided by the manufacturer and is contained in the owner's packet.

To operate:

1. Be sure the generator seacock (located forward of the engines) is open.
2. Be sure the AC circuit breaker, located on the controller, is ON.
3. Turn OFF the selector switch located in the cabin.
4. Operate the blower for at least four (4) minutes.
5. Start the generator, following the manufacturer's instructions. Allow the generator to operate for at least one (1) minute to stabilize the voltage.
6. Turn the selector switch to **GENERATOR**.
7. Switch the main AC circuit breaker ON, and then the respective branch breakers below it as needed.

DO NOT operate the generator while boat speeds are above 40 MPH!

FUEL SYSTEM



The fuel system, including the fuel lines, filter, and pump, should never be serviced by any person other than an authorized Cobalt-trained service technician.



The flammability of gasoline and its explosive properties must always be respected. At the first odor of gasoline, the propulsion unit (engine) should be shut off and remain off until the source of the odor has been identified and the issue has been rectified.

Fuel Requirements

Cobalt fuel systems are designed to meet all current ABYC and NMMA regulations using gasoline (petrol) with up to 10% ethanol.



DO NOT use fuels containing methanol (methyl alcohol) or other fuels with more than 10% ethanol (ethyl alcohol) content such as E85, which contains 85% ethanol.

NOTICE

Use of incorrect fuel can result in damage to the propulsion unit (engine) that is not covered by the propulsion unit manufacturer nor by Cobalt. Failure to follow maintenance requirements may also void the warranties.

Fuel that contains more than 10% ethanol voids all warranties and will increase the risk of damage to the engine(s), fuel system components and will also lead to the following;

- Corrosion of metal parts;
- Deterioration of plastic, rubber parts or permeation of fuel through rubber fuel lines;
- Leaking fuel resulting in explosion and/or fire;
- Starting and operating difficulties;
- Potential damage to your engine.



Fueling



Take care not to spill gasoline. If gasoline is accidentally spilled, wipe up all traces of it with dry rags and immediately dispose of the rags properly ashore.

NOTICE

Spilled fuel may yellow the gelcoat finish and damage gunwale trim. Such damage is not covered under warranty.



Take all precautions every time you fuel your boat, regardless of the fuel type. Certain fuel is extremely flammable and highly explosive under certain conditions. Fumes from improperly stored rags can collect in bilge and be extremely hazardous.

! DANGER

Operate the blowers for at least four (4) minutes.

NOTICE

Prevent unwarranted engine damage. Use the recommended fuel type and octane rating. Refer to your propulsion unit operator's manual.

! DANGER

Fuels are extremely flammable and highly explosive under certain conditions.

- Stop engines, generators and any fuel-operated machinery.
- **DO NOT** smoke or allow open flames or sparks within 60 ft (15 m) of the fuel area.

! DANGER

Never smoke nor operate any spark-producing object within a 60-foot range (15 meters) of the boat when fueling. Fumes from gasoline are more likely to produce an explosion and/or fire than the actual fuel.

- Avoid damaging fuel lines and connectors, and the contact of fuel on hot engine parts.
- **DO NOT** store fuel in any containers or compartments which are not designated for fuel storage.
- Clean up any spilled fuel immediately and dispose of rags properly ashore.
- Know the dangers associated with fuels.

! DANGER

Each time you refuel, inspect all fuel lines, hoses and connections for leaks and deterioration.

- The Federal Water Pollution Control Act prohibits the discharge of oil or oily waste into the water. Violators can be fined \$5,000.00. Operation is also affected by the MARPOL Treaty. (See the Safety section of this owner's manual for more details.) We urge you to protect our fragile environment by avoiding any type of discharge, including trash or litter, into our waterways.

When Fueling:

1. Know your fuel tank capacity. Be sure to have enough fuel to reach your destination. If departing for an extended cruise, know the availability of fuel along your route. Practice the One Third Rule: one-third to reach the destination, one-third to return and one-third in reserve.
 - a. Even when the fuel system is carefully attended, some water may get into the fuel tank or separate from the fuel that is pumped into the tank. If there is water present, it

will settle on the bottom of the tank. If the pump begins to reach any water, it may cause a malfunction in the engine. Therefore, it is advisable to avoid allowing the fuel level to get too low.

2. Avoid fueling at night, except under well-lit conditions.
3. Moor your boat securely to the dock. Know the location of the fire extinguisher in case of emergency.
4. Keep accurate records of your fuel consumption. A fuel log that tracks fuel use over time will help determine average consumption.
5. Close all doors, hatches, windows and other compartments.
6. Extinguish cigarettes, pipes and all other flame-producing items.
7. Make sure all power is off, and do not operate any electrical switches.
8. Remove the fuel filler cap.
9. Insert the hose nozzle and make sure the nozzle is in contact with or grounded against the fill opening. This will reduce the risk of static spark.

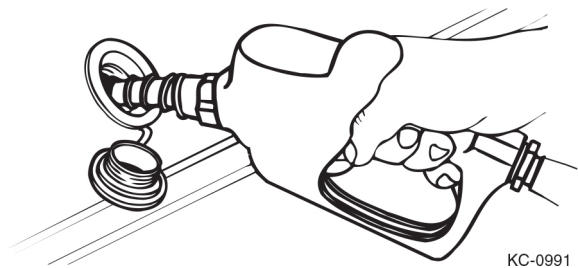

When your boat is equipped with the pop-up fuel filler cap, open by pressing the cap and turning the cap counter-clockwise (approximately 10°); remove the cap.

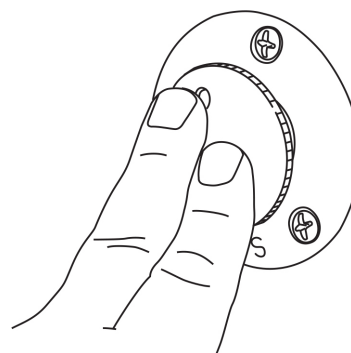

To close:

Reinstall the cap, press and turn clockwise. The fuel cap key is not necessary unless the cap is overtightened.

1. Add fuel in accordance with the propulsion unit operator's manual. Do not overfill, and allow enough room for fuel expansion.

The fuel cap is retained by a chain to prevent losing the cap after it is opened. Be careful when fueling to avoid damaging the chain. If it breaks, have it replaced.

After Fueling:

1. Tighten the fuel fill cap using the fuel cap key unless your filler cap is the pop-up type. Wipe up any fuel spills.
2. Open all windows, hatches, doors and compartments.
3. Check all fuel lines, hoses and connections for leaks and

deterioration.

4. Be sure to run the blower for at least four (4) minutes before starting the engine. If you smell gasoline fumes, do not start the engine; continue to run the blower until the fumes have dissipated.



EPA Fuel Tank

Your Cobalt boat may be equipped with a fuel system that has been designed and manufactured to meet the latest U.S. Coast Guard and EPA EVAP (evaporation) regulations. A decal located at the helm will indicate if your boat is equipped with this fuel system.

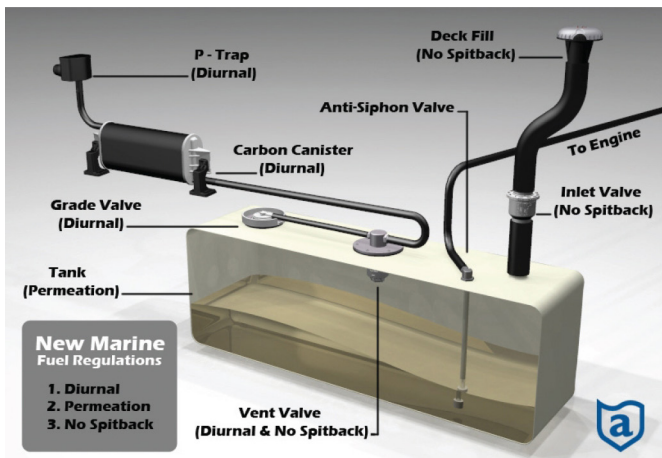

Some of the new features in the fuel system:

- There is no “spitback” at the deck plate when fueling. The filler nozzle automatically shuts off when the tank is full. Do not attempt to continue filling after the nozzle automatically shuts off, indicating the tank is full.
- A carbon canister is present to capture hydrocarbon molecules before air is vented outside the fuel system.

When filling the tank for the first time:

- Fuel vapor will expand within the tank, causing back pressure that may close the inlet check valve and cause the filler nozzle to prematurely shut off. To eliminate this problem, slowly add only about 2 gal (7.5L) of fuel and stop. Wait a few minutes to let the pressure within the

system stabilize; then proceed filling the tank.

- During the first few fills, the new carbon canister within the vent line may generate heat from being initially saturated with hydrocarbons and cause water droplets to emit from the outside air vent. This is normal. After the first two or three fills, this should not happen.



Troubleshooting

New tank is hard to fill/nozzle keeps shutting off.

This is called the “Green Tank Effect.” With a new tank that has never been fueled, the internal tank volume is completely filled with fuel vapor, very similar to what also occurs in non-diurnal tanks. The difference is that the newer tanks do not cause significant spitback. Instead, the nozzle shuts off. When filling a tank for the first time, the fuel vapor expands and builds back pressure, shutting the inlet check valve and causing the nozzle to shut off.

To eliminate this problem, add a few gallons to the tank very slowly and allow it to sit for several minutes. Then proceed with normal filling.

Hot air comes out of the vent and drips liquid.

This is completely normal. When a tank is filled for the first time, the canister becomes saturated with hydrocarbons and generates heat as it performs the intended function. This water from the vent is simply water vapor condensation as a result of the carbon canister operating correctly and stopping hydrocarbons (fuel vapor) from venting into the atmosphere. After the first two or three fills, the system will stabilize, and this will cease.

Cannot “top off” or keep filling the tank after it shuts off.

This is due to EPA regulations preventing overfilling the tank with the purpose of preventing expansion which could cause fuel to overflow through the vent.

DO NOT CONTINUE TO FILL THE TANK AFTER IT IS FULL AND THE NOZZLE SHUTS OFF.

FRESH WATER SYSTEM

If the Cobalt boat is equipped with a shower, and/or a standard or optional galley, the system allows for fresh water to be pumped onboard. A 12-volt DC water pump operates the system. It is necessary for the boat’s battery(ies) to be turned on for the water system to operate. The WATER PRESSURE switch must be turned on to operate the water system.

As standard procedure, the water system is winterized from the factory and the water from the factory is non-potable. DO NOT DRINK IT. They system must be

cleaned and disinfected before the first use.

Important specific component information appears later in this chapter. See Specifications in this owner’s manual, for the boat’s fresh water capacity. In addition to information provided in the *Interior/Exterior Care and Maintenance* section of this owner’s manual, you can also consult with your authorized Cobalt dealer for winterization requirements.



HELM AND INSTRUMENTATION

A29 Helm

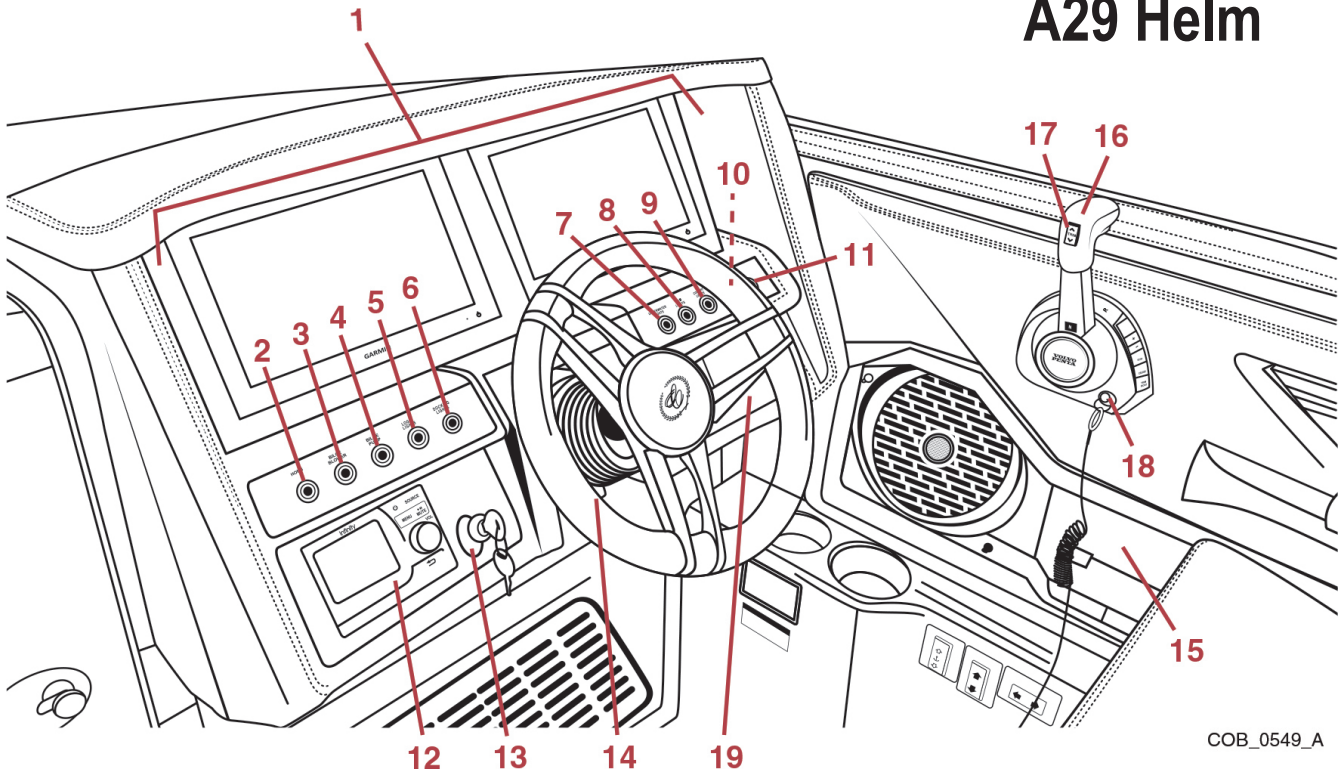

COB_0549_A

R30 Helm

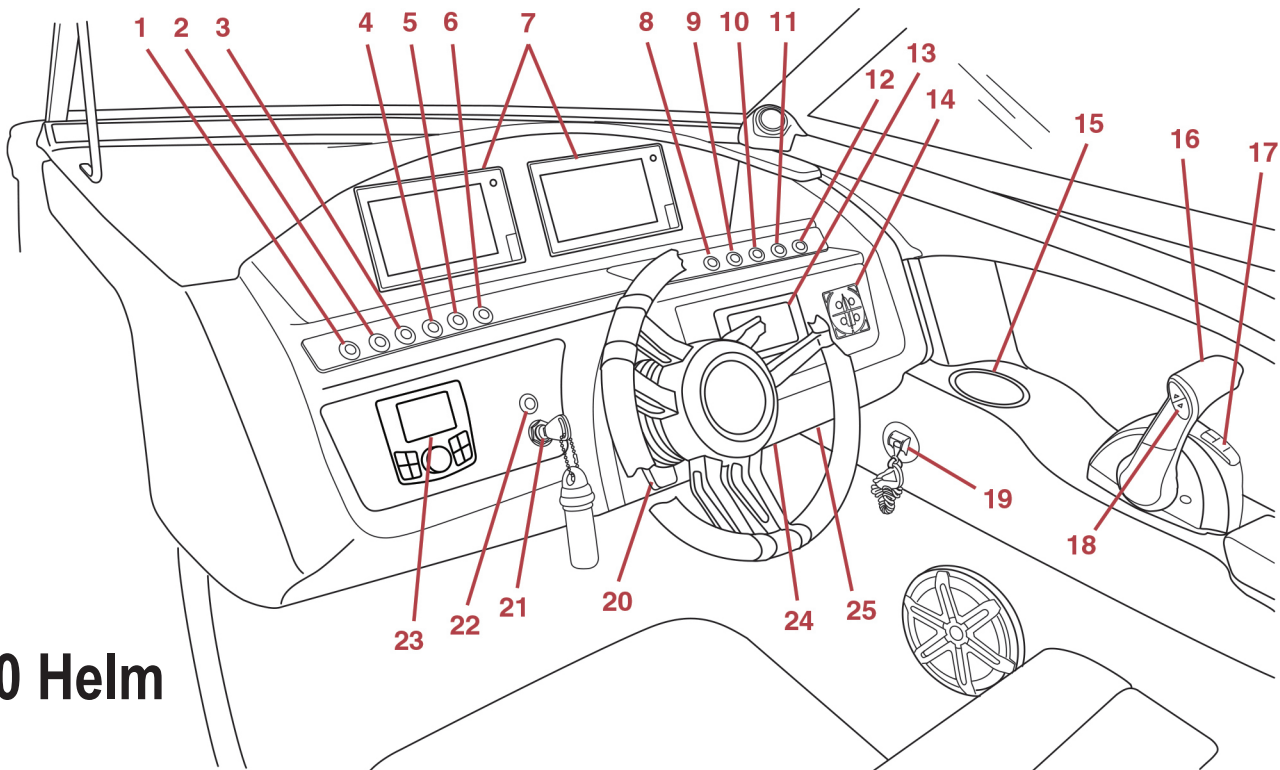

COB_0467_A

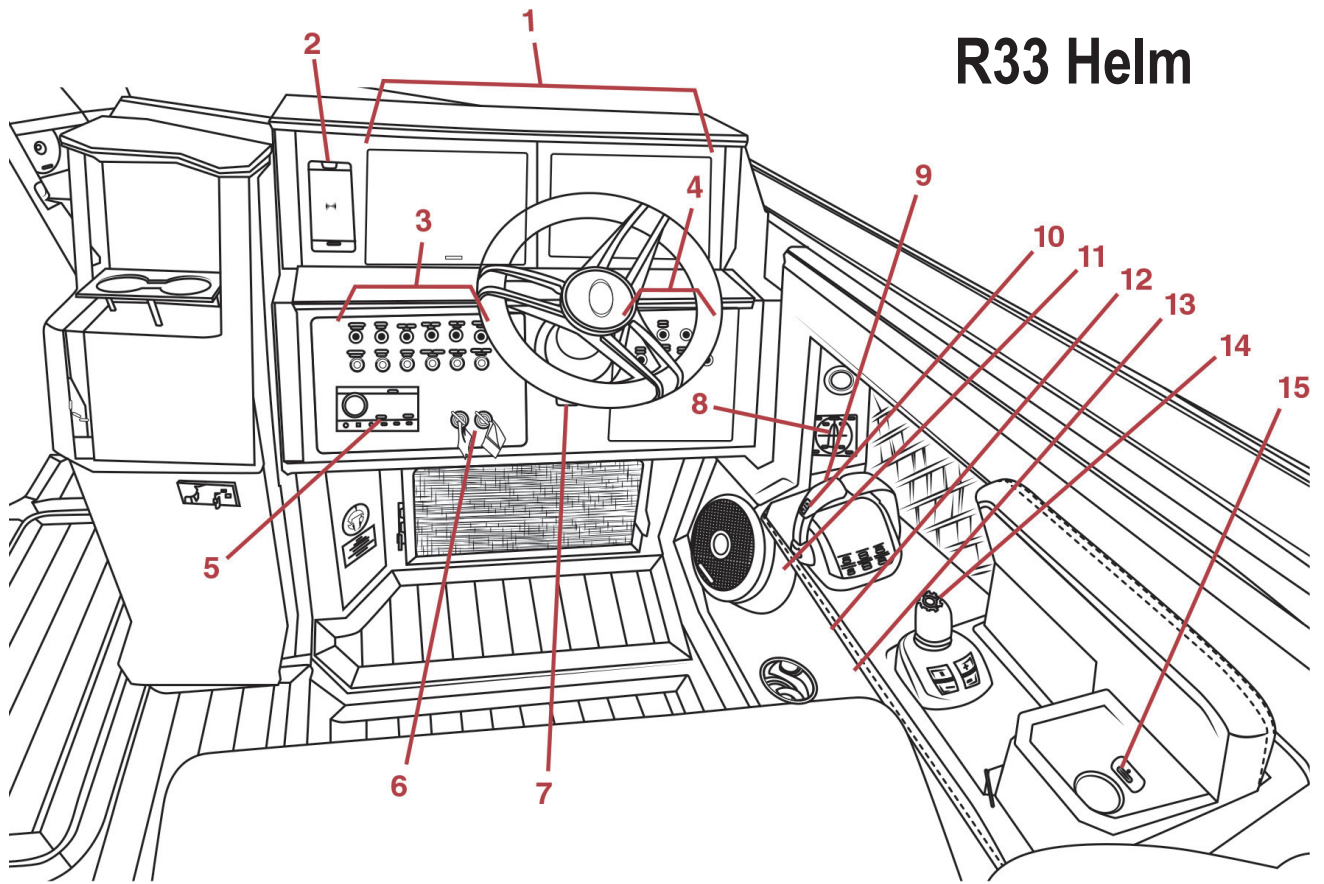

R33 Helm

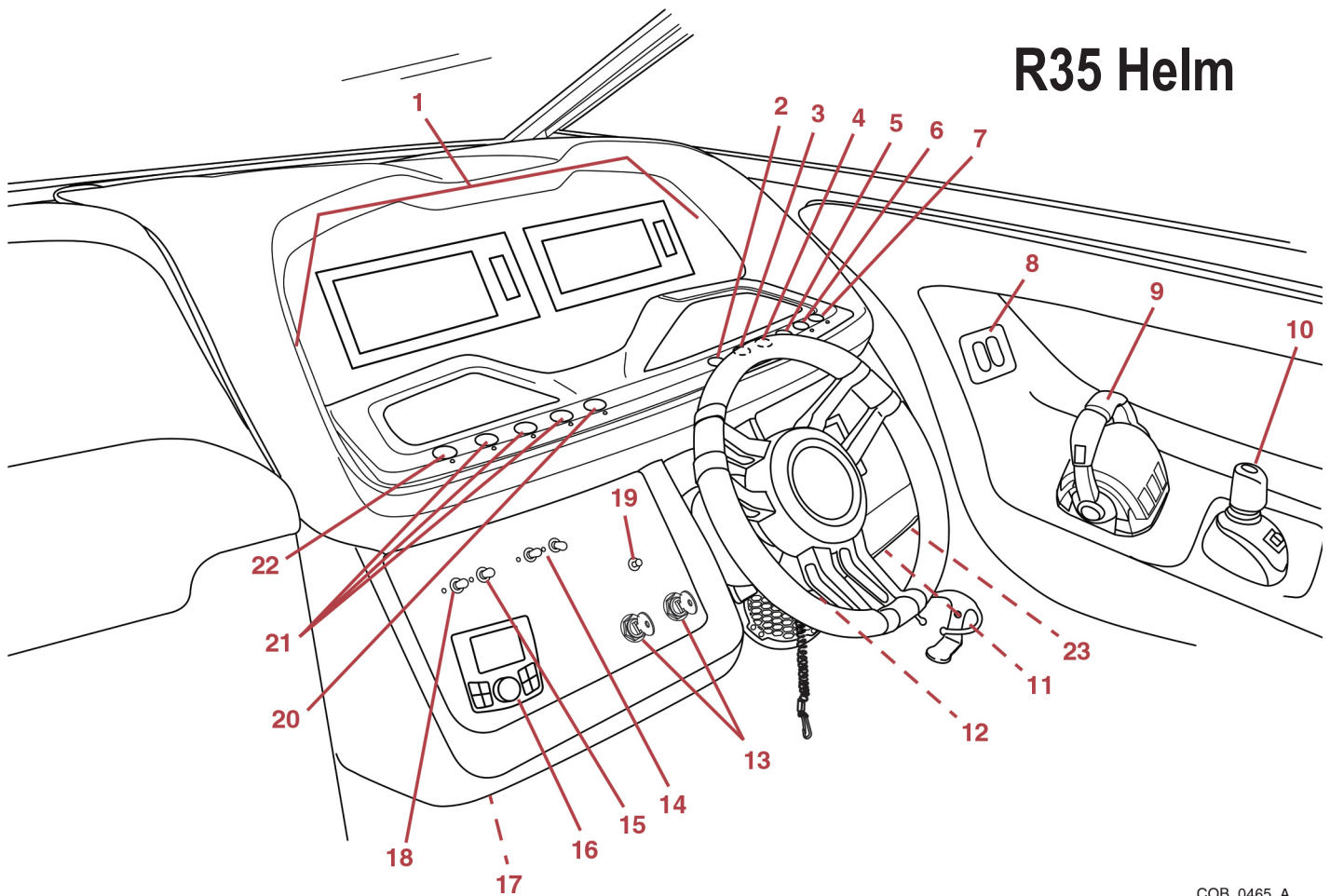

R35 Helm

Your Cobalt boat helm will monitor and provide information about the boat's functions. The gauges are illuminated for night or low-light operation.

On occasion, a small fluctuation in a gauge reading is not unusual. If an instrument reading is outside the normal or recommended ranges, determine the cause or see your authorized Cobalt dealer.

Refer to the engine operator's manual for normal recommended ranges.

 **WARNING**

If the safety of you or others depends on running the engine during abnormal conditions, make the right decision on saving equipment or lives. Do not jeopardize the safety of you or others to protect your boat.

On the drawings the number corresponds with the number shown immediately after the component or switch, i.e., Bilge Blower—On R30 Helm: 1 means that on the R30 Helm drawing, the Bilge Blower will be designated as #1.

Components and Switches (alphabetically)

Accent Light Switch and Dimmer (Optional)—On A29 Helm: 19; R30 Helm: 25; R33 Helm: 4; R35 Helm: 23

Use of lighting on the boat is regulated, and it is the responsibility of the boat operator to learn, understand and comply with all local, state and federal laws regarding the acceptable use of all lighting components on the boat. Some color lights may not be compliant with certain local ordinances.

Accessory Switch (ACC 1, 2)— On R30 Helm: 6; R35 Helm: 2

These switches are available to operate other accessory items that require a switch to operate.

 **CAUTION**

DO NOT connect an accessory that is drawing more than 10 amps to the accessory switch. A hazardous situation, failure or damage to the electrical system can occur.

Bilge Blower—On A29 Helm: 3; R30 Helm: 1; R33 Helm: 3; R35 Helm: 22

This switch activates the engine compartment ventilation blower to remove explosive fumes from the area. The blower must be operated for a minimum of four (4) minutes each time before starting the engine. In addition, the blower should be operated continuously when at idle or running at slow speeds. The LED will illuminate if the switch is ON. Additional information about this critical component is presented throughout this manual.

 **WARNING**

Never overlook the requirement of operating the blower for a minimum of four (4) minutes when the engine is started, or running the blower continuously when at idle or slow speed as the build-up of vapors can result in an explosion resulting in serious injury or death.

Bilge Pump—On A29 Helm: 4

This switch manually controls the bilge pump.

Bilge Pumps—On R33 Helm: 3; R35 Helm: 21

These switches manually control the Aft, Mid (midship) and Fwd (forward bilge pumps).

Bilge Pump Aft— On R30 Helm: 3

This switch manually controls the aft bilge pump.

Bilge Pump Fwd— On R30 Helm: 2

This switch manually controls the forward bilge pump.

 **WARNING**

The bilge system is critical to ensuring safety. Excess water drains into the bilge and must routinely be pumped out to keep the boat afloat and in trim. Failure to pay attention to water removal can result in sinking the boat, resulting in possible serious injury or death.

Captain's Call Exhaust (Optional)—On R35 Helm: 20

This switch determines the routing of the engine exhaust. In the ON position, the engine exhaust is routed through the thru-hull pipes. This position produces the most engine power, but it is not acceptable near shore or on inland lakes and rivers.

In the OFF position, engine exhaust is routed through the hub of the propeller. This position releases the exhaust underwater, providing a quieter engine.

Be sure to check local regulations regarding noise restrictions before operating the system.

NOTICE

To avoid damage to the exhaust system, do not switch exhaust when the engine is running above 3,000 RPM.

 **DANGER**

Carbon monoxide (CO) is colorless, odorless and dangerous. Direct and prolonged exposure to CO will cause brain damage or death. Dissipation of CO is critical for safe boating. Be sure to read the Safety section of this owner's manual regarding how to avoid breathing CO or being in situations in which CO may be trapped and create situations that may result in serious injury or death.

Cell Phone Charger (Optional)—On R33 Helm: 2

The cell phone charger securely holds and wirelessly charges cell phones. Ensure that the phone will charge wirelessly as not every cell phone will work in this manner.

Circuit Breakers—On R30 Helm: 26; R35 Helm: 17

Breakers are located in the starboard bow storage compartment for the helm-labeled, protected device. These breakers will activate if overloaded and cut power to the switch. To restore power, turn off the device, push the breaker button in and release. If the button continues to activate when the device is used, see an authorized Cobalt dealer for assistance. Cut power to the switch when activated and clear the fault before resetting. If the fault cannot be cleared, contact your dealer immediately before restarting. Additional information regarding circuit breakers appears in the Electrical Systems section of this chapter.

Cockpit Heater Switch (Optional)—On R33 Helm: 12; R35 Helm: 3

The switch turns the cockpit heater ON/OFF.

Cockpit Lights—On A29 Helm: 9; R30 Helm: 4; R33 Helm: 3; R35 Helm

This switch provides illumination within the cockpit area. These lights are useful for movement by persons onboard. Cobalt recommends leaving them off unless the boat is moored and people are expecting to move about the vessel.

Cup Holder—On R30 Helm: 15; R35 Helm

A standard-sized cup holder is molded into the driver's-side armrest. Cobalt recommends placing only cups/bottles that easily slide into and fit the cup holder. Drink dispensers that are either larger or smaller will likely fail to remain secure.

Docking Lights (Optional)—On A29 Helm: 6; R30 Helm: 12; R33 Helm: 4; R35 Helm: 5

This switch operates the docking lights, where equipped. Docking lights are to be used for docking only. It is illegal to use your docking lights while cruising.

Drive Unit Trim Switch— On A29 Helm: 17; R33 Helm: 10

This switch controls the trim angle of the drive unit. It will maximize the performance and ride of the boat. When combined with the optional trim tabs, it also enhances the experience.

Engine Compartment Lights—On R35 Helm: 4

This switch provides illumination within the engine compartment.

Engine Display—On R30 Helm: 13

This screen provides data regarding engine function.

Engine Hatch—On R33 Helm: 3; R35 Helm: 15

The switch operates the electric motor box assembly. **DO NOT** continue to operate the switch when the motor box is closed or fully open. Lower the motor box support after the motor box is opened. Be sure to return the support to its stowed position before attempting to lower the motor box.

Engine ON/OFF Switch—On R30 Helm: 21; R33 Helm: 6; R35 Helm: 13

Refer to the propulsion unit's owner's manual in the owner's packet for specific engine starting and stopping procedures.

Note that whenever the ignition switch is turned on, it is pulling power from the battery. Extended periods of leaving the switch turned to *Accessory* can drain a battery and eventually the boat engine cannot be turned on and run. Such action can result in being stranded away from the dock or shore.

- Check the engine compartment for gasoline or vapors.
- Operate the blower for four (4) minutes.
- Verify the blower operation.
- Run the blower below cruising speed.

Glass Cockpit Dash Unit—On A29 Helm: 1; R30 Helm: 7; R33 Helm: 1; R35 Helm: 1

Smart Mode screens are pre-programmed by Cobalt. To access screens:

1. Press **HOME**, if not already there.
2. Press **Smart Mode**.
3. Select desired mode from **Smart Mode** screen.

NOTICE

To reset to default settings, contact your Cobalt dealer. Attempting to reset without guidance can cause malfunctions that may inhibit the ability to run the boat.

A/V, Gauges/Control settings are auto-populated, depending on options; however, they can be customized. (For example, to adjust screen brightness, press and release the power button quickly.)

EVC is Volvo Penta's electronic engine control platform and is offered as an option. EVC connects the engine, transmission, instruments and accessories into one operating system. The result is high reliability, simple updates and access to smart accessories.

If your boat is equipped with EVC, when the engine is turned off, turn the key back to the ON position within two (2) seconds. The screens will stay on. From Power Off, it takes approximately 60 seconds for displays to boot up.

If your boat is equipped with EVC, the functions of the

engine data will not populate without the Volvo trip computer option.

For more detailed information, you can review your owner manual on the screen under info or the *Garmin Quick Start Manual* in your boat owner's packet. You can also go to garmin.com under *Marine Device Software Updates* for the latest software updates, if desired.

Helm Seat Switch—On R33 Helm: 13

Controlling the position of the helm seat, allows it to move forward and aft. Additional information is available in the Comfort and Enhancements portion of this chapter regarding the helm seat operation.

Ignition Switch—On A29 Helm: 13

This switch starts the engine. It also supplies accessory power when turned to the left.

- Check the engine compartment for gasoline or vapors.
- Operate the blower for four (4) minutes.
- Verify the blower operation.
- Run the blower below cruising speed.

Ignition (Port/Starboard)—On R35 Helm: 13

On boats with more than one engine, each engine has its separate ignition switch. The left switch is for the port engine, and the right switch is for the starboard engine.

- Check the engine compartment for gasoline or vapors.
- Operate the blower for four (4) minutes.
- Verify the blower operation.
- Run the blower below cruising speed.

Horn—On A29 Helm: 2; R30 Helm: 22; R33 Helm: 4; R35 Helm: 19

This switch activates the horn. Press the switch to activate. Release to stop the sound. The horn is a safety feature to sound an alarm in the event of an emergency and to draw attention when maneuvering in areas where the line of sight is questionable or instances when attention seems warranted.

Ignition Safety Switch—On A29 Helm: 18; R30 Helm: 19; R33 Helm: 11; R35 Helm: 12

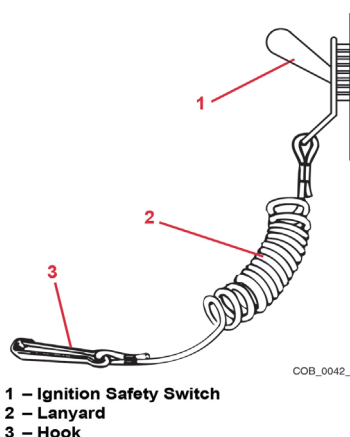

WARNING
DO NOT allow your boat to be operated without the proper use of the ignition safety switch and lanyard.

Your Cobalt boat is equipped with an ignition emergency safety switch located on the lower edge of the helm. The ignition emergency

safety switch, attached by a lanyard, will stop the engine in case of an emergency, when used properly and as directed. Attach the lanyard to the boat operator's clothing whenever the engine is running, but be aware there will be a loss of boat control if the switch is activated. If the operator is thrown from the seat or moves too far from the helm, the lanyard will become disconnected from the ignition emergency safety switch, shutting off the engine.

To reset the switch after activation, reinstall the lanyard clip and flip the switch to the UP position.

! DANGER

The ignition emergency safety switch lanyard should always be connected between the switch and the operator when the engine is running. The purpose of the switch is to immediately shut OFF the engine if the operator moves away from the driver's helm. Without the driver's control, all persons onboard or other boaters in the area could be subject to serious injury or even death. Never operate the boat without the emergency engine stop switch lanyard connected between the switch and the boat operator. Cobalt recommends the operator of the vessel always remain at the helm any time the engine is running.

! DANGER

The ignition emergency safety switch can only be effective when it is in good working condition. Observe the following:

- Do not remove or modify the ignition emergency safety switch and/or lanyard.
- The lanyard must be free from obstructions that could interfere with its operation.
- DO NOT operate the boat if the ignition emergency safety switch does not function properly.
- Attach the ignition emergency safety switch lanyard to a secure place on your clothing or person while operating.
- DO NOT attach the lanyard to clothing that could tear loose. DO NOT route the lanyard where it could become entangled, preventing it from functioning.
- Avoid accidentally pulling the lanyard during normal operation. Loss of engine power means loss of most steering control. Also, without engine power, the boat could slow rapidly. This could cause occupants and objects in the boat to dislodge, which could result in serious injury or even death.

Joystick Control—On R33 Helm: 14; R35 Helm: 10

Refer to the joystick control operator's manual for operation instructions.

Logo Lights—On A29 Helm: 5; R33 Helm: 4

The switch illuminates the boat logo at the walk-thru. Turn ON/OFF.



Media Center—On R30 Helm: 23

The media center controls various functionality including the stereo system. Additional information about this appears elsewhere in this manual.

Navigation Lights; Anchor/Mooring Light—On A29 Helm: 10/11; R30 Helm: 10/11; R33 Helm: 3; R35 Helm: 18

For Inland Rules only. Do not use in international waters. You must use your navigation lights and anchor/mooring light when operating your Cobalt boat between sunset and sunrise, and when daytime visibility is limited (i.e., rain and fog). Before operating your boat, check with your local authorities for other requirements concerning the use of navigation lights. The U.S. Coast Guard and many maritime authorities require recreational vessels to display navigation and/or anchor lights when the boat is deployed and/or moving on the body of water during periods of reduced visibility. The navigation lights are identified by a red light on the port side and a green light on the starboard side.

All boats at anchor or moored must display a proper white anchor light. The anchor light (all-around light) is the

white light that is installed into a receiver located aft of the cockpit. The anchor light must be visible from 360° and will remain on when operating the navigational lights.

⚠ WARNING

Boat outings should conclude prior to dark. Visual sighting is critical to safe boating. In an emergency where the boat must be operated in darkness, use the boat's navigation and anchor lighting in accordance with local law and ordinances, which may restrict the type of lighting to be used; plus, sound signals to alert anyone in the area, and proceed slowly. After dark, it may be impossible to see other boats, submerged hazards, or the shoreline, which can result in damage to the boat that is not covered under warranty, and serious injury or even death.

Overhead Lights— On R30 Helm: 5

This switch provides illumination into the cockpit area from the hardtop cover, where equipped. Cobalt recommends leaving these lights off unless the boat is moored and people are expecting to move about the vessel.

Shift/Throttle Lever— On A29 Helm: 16; R30 Helm: 16; R33 Helm: 9; R35 Helm: 9

To the right of the boat operator is the shift/throttle levers. Any time the boat engine is off, the levers should be in the center upright position, which is **NEUTRAL** (meaning the boat is not in gear) and is apparent when it can be felt slotting in with an auditory click. Boats are not equipped with “Park” like land-based vehicles.

At the base of the throttle is a detent button. Pushing on the button disengages the transmission, thereby allowing use of the throttle without engaging the transmission. This is used for warm-up of the engine while it is still in **NEUTRAL**. Be sure to position the throttle vertically (neutral) before re-engaging the transmission by again pushing the button.

When shifting gears, always do so smoothly and briskly. Being either too hard and slamming the gears, or too tentative is hard on the shift/throttle system and can result in damage that is not covered under warranty.

Refer to the engine operator’s manual for more information and functions of the remote control.

DO NOT shift when the engine is not running.



Before starting the engine or engaging the transmission, be certain that there are no people in the water around the boat.



Make sure all shift/throttle hardware and cables are regularly inspected and maintained by authorized Cobalt dealers. Improperly maintained controls are hazardous and may cause sudden loss of control.



DO NOT shift from forward to reverse while the engine is at high RPM. Damage to the transmission will result. When shifting from forward to reverse, the system requires a brief pause in the NEUTRAL position to allow the engine to return to its idle position prior to moving into the opposite gear. Without the brief pause, action can cause the engine to shut off. The subsequent loss of control can cause damage to the boat and/or injury to persons in or around the boat.

When shifting from **NEUTRAL** to **FORWARD** or **REVERSE**, shift briskly and decisively.

Your Cobalt boat is equipped with a safety switch for “start in neutral-only” operation. The shift lever must be in the **NEUTRAL** position before attempting to start the engine. See the information above for more detail.

Stereo Remote Control (standard on IPA, optional as a transom mount)—On A29 Helm: 12; R33 Helm: 5; R35 Helm: 16

The panel provides remote control of the stereo system from the helm.

Storage Lights—On R33 Helm: 4

This switch turns the interior lights ON/OFF.

Swim Platform Lights (Optional)—On R30 Helm: 9; R33 Helm: 3; R35 Helm: 6

This switch turns on and off the swim platform lights, similar to the underwater lights.

Tilt Steering Release Lever—On A29 Helm: 14; R30 Helm: 20; R33 Helm: 7

This lever allows the operator to adjust the steering wheel to the most comfortable angle and provide a sense of secure control. Steering columns have a lever at the underside of the column. Press down on the lever until the steering wheel is movable. Tilt it up or down to the best angle for the operator and re-engage the lever snug against the steering column. Never force the lever. If it will not move with relative ease back into place, the steering wheel is not in one of its acceptable levels. Adjusting slightly should allow proper action of the tilt mechanism.



Adjust the steering wheel only when the boat is not moving. If necessary, slow to idle to make adjustments. Attempting to adjust the tilt mechanism while the boat is in motion could cause the operator to lose control of the vessel.

Trim Tab Switches— On R30 Helm: 14; R33 Helm: 8; R35 Helm

The switches will not operate unless the engine(s) is running. The left switch controls the starboard side and the right switch controls the port side. Press the **UP** and **DOWN** buttons for manual operation. Pressing the **AUTO** button will allow automatic leveling of the boat. When in **AUTO** mode, the auto light will be **ON**.

Trim Tab Switches/Trim Indicator—On R35 Helm: 8

The switches will not operate unless the engine(s) is running. The left switch controls the starboard side and the right switch controls the port side. Press the **UP** and **DOWN** buttons for manual operation. Pressing the **AUTO** button will allow automatic leveling of the boat. When in **AUTO** mode, the auto light will be **ON**. The indicators display the relative position of the trim tabs.

Underwater Lights (Optional)—On R30 Helm: 8; R33 Helm: 4

This switch provides illumination underwater. These lights should also be off during cruising; some locales legally require these be off when moving.

Underwater Lights—RGB (Optional)—On A29 Helm: 7; R33 Helm: 4; R35 Helm: 7

This switch provides illumination underwater. These lights should also be off during cruising; some locales legally

require these be off when moving. See the provided RGB manual for more details.

USB/Accessory Power Receptacle—On A29 Helm: 15; R30 Helm: 24; R33 Helm: 15; R35 Helm: 11

The boat is equipped with a USB port. On some models there are more than one. Note that these USB ports are for charging only; they are not connected to the stereo system. Only the USB port at the glove box is connected to the stereo.

Wake Surf Controls (Optional)—On R33 Helm: 16

Where equipped, the control information is explained in detail in this chapter under *Performance Boosts, Wake Surf Control*.

Windlass Control (Optional)— On R30 Helm: 3; R35 Helm: 14

The optional windlass system can be electronically operated from the helm. For operation of the windlass system, refer to anchoring information provided in this owner's manual.



Engine Alarm

Your Cobalt boat may be equipped with a warning system that will sound an alarm if an engine problem develops. The horn may emit a short chirping sound during starting to verify operation. If the warning horn sounds when operating the boat, **IMMEDIATELY** throttle back to idle speed and shift into the NEUTRAL position. **IMMEDIATELY** check the gauges and stop the engine.

NOTICE

Continued operation after the warning alarm has sounded may cause severe engine damage.



Bilge Alert Alarm

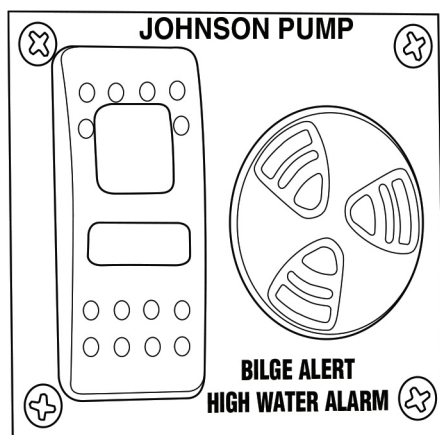

If there is too much water in the bilge area of the boat, a sensor will sound a high-water alarm. The sensors are located in the *engine compartment*. The alarm switch is located in the day cabin.

A three-position switch is located by the alarm. The center position is the OFF position. Pressing on the top of the switch will test the alarm. Pressing on the bottom of the switch will arm the system and a light will illuminate on the top of the switch. The system should be armed, especially when the boat is anchored or when people are sleeping in the cabin.



Carbon Monoxide Detector

A carbon monoxide detector is located in the berthing area. The detector receives power from the 12V DC system. The detector will be operational any time the battery power is ON. When occupying the boat, make sure power is supplied.

The green light on the detector may flash for fifteen (15) minutes while it warms up; however, it is fully functional during this period.

If the unit alarm sounds, evacuate all persons from the cabin area to fresh air **IMMEDIATELY** and investigate the cause. **DO NOT** return to the cabin area until the cause of the CO has been identified and corrected.

For additional information, refer to the carbon monoxide detector operating instructions in the owner's packet.



All gasoline and diesel engines, along with fuel-burning appliances such as heaters, stoves and generators, produce carbon monoxide (CO). It is a colorless, odorless, and dangerous gas. Direct and prolonged exposure to CO will cause brain damage or death. Signs of exposure to CO include nausea, dizziness, drowsiness, ringing ears, headaches, unconsciousness and bright red skin color. Avoid exposing everyone on-board to CO. Test the carbon monoxide detector operation before each trip, at least once a week, and after the boat has been in storage. DO NOT tamper with the operation of the CO detector. It is installed for your safety.

CO poisoning should not be confused with seasickness, intoxication or heat stress. If someone complains of irritated eyes, headache, nausea, weakness or dizziness, or if for any reason CO poisoning is suspected, **IMMEDIATELY** move all persons to fresh air, investigate the cause, and take corrective action. Seek medical attention as necessary.

A CO detector will detect only the presence of carbon monoxide gas at its sensor and will not detect other vapors such as gasoline. CO may be present in other areas. Never ignore any symptoms of illness, regardless of the location from the CO sensor.

Electronic devices have limited life spans and may fail without warning. Inspect the CO detector regularly. Refer to the detector manufacturer's manual and follow the recommendation for replacement.

BASIC FUNCTION FEATURES

Removable Ski Tow Pylon

The stainless-steel ski tow pylon is designed for a single skier only. The ski tow pylon is normally located at the stern of the boat or on the ski tower.

To install:

Remove the pylon from the starboard, bow storage compartment by pulling the lock button outward and opening the hold-down bracket.

- Lift the pylon base cover on the swim platform.
- Push the pylon down and rotate one-quarter (1/4) turn clockwise to lock in place.
- Be sure the pylon is secure before use.

WARNING

DO NOT overload the ski tow, ski tow eye or the ski tow pylon, or use them for anything other than water sports. The ski tow eye and the ski tow pylon maximum load is 1,000 lbs (454 kg).

WARNING

DO NOT allow passengers to sit behind the pylon whenever someone in the water is being towed. When the towed individual lets loose of the ski/wakeboard rope, the tension may cause the rope and its tow handle to snap back into the deck area. Individuals may not be able to deflect the rope, with the result that people hit by the rope and handle could be injured, especially if they are not paying attention.

WARNING

Tow point failure can result in serious injury or death. **DO NOT** attach tubes, inflatables, toys, vessels, etc., to this tow point. Only use this water sports tow point for single-person skiing, wakeboarding, and wake surfing, etc. **DO NOT** attempt to use the pylon for any purpose other than towing individuals behind the boat with an appropriate towing rope. **DO NOT** attempt to tow another boat by attaching a rope to the pylon. This will overload the pylons and can cause damage to the boat which will not be covered under warranty.

To remove the pylon:

- Pull up and rotate the pylon one-quarter (1/4) turn counterclockwise to loosen and remove.
- Close the base cover and return the pylon back to its hold-down bracket in the starboard, bow storage compartment. Be sure the hold-down bracket is securing the pylon.

NOTICE

To prevent damage to the motorbox (where equipped), remove the pylon before opening the motorbox.



Tie-Down Locations

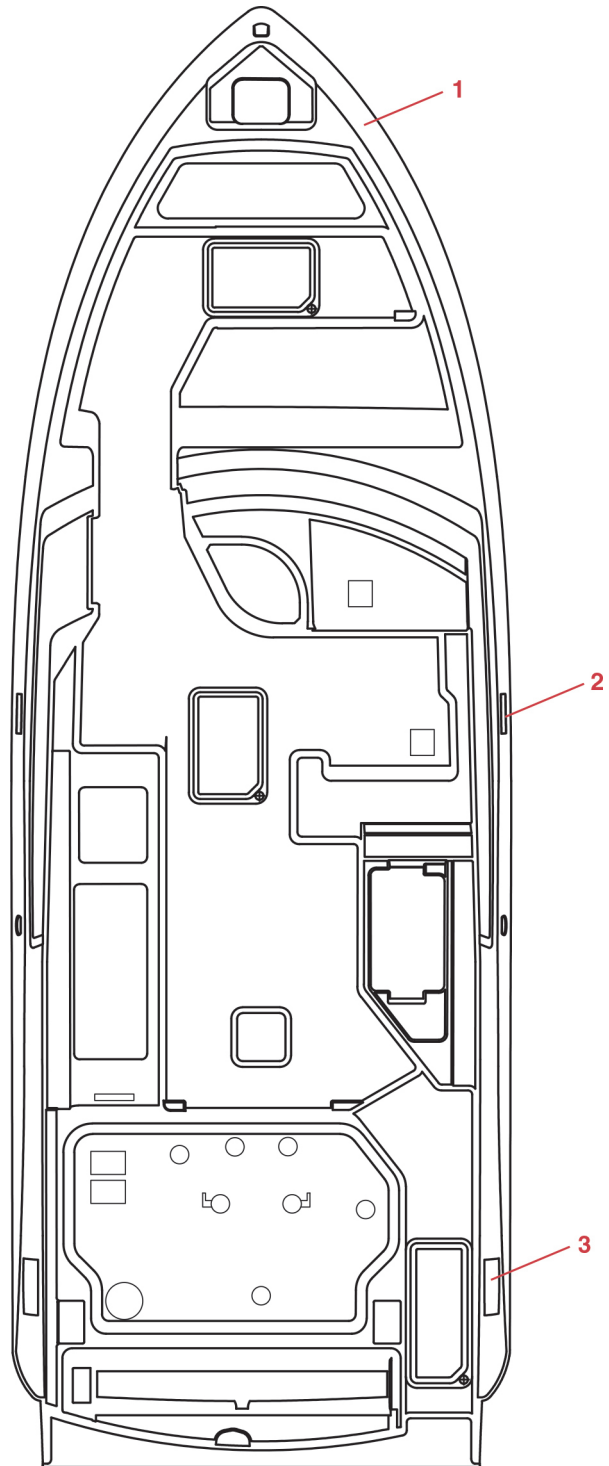

COB_0544_A

- 1 – Forward Cleat Location
- 2 – Mid Cleat Location
- 3 – Aft Cleat Location

A29 Tie-Down Locations

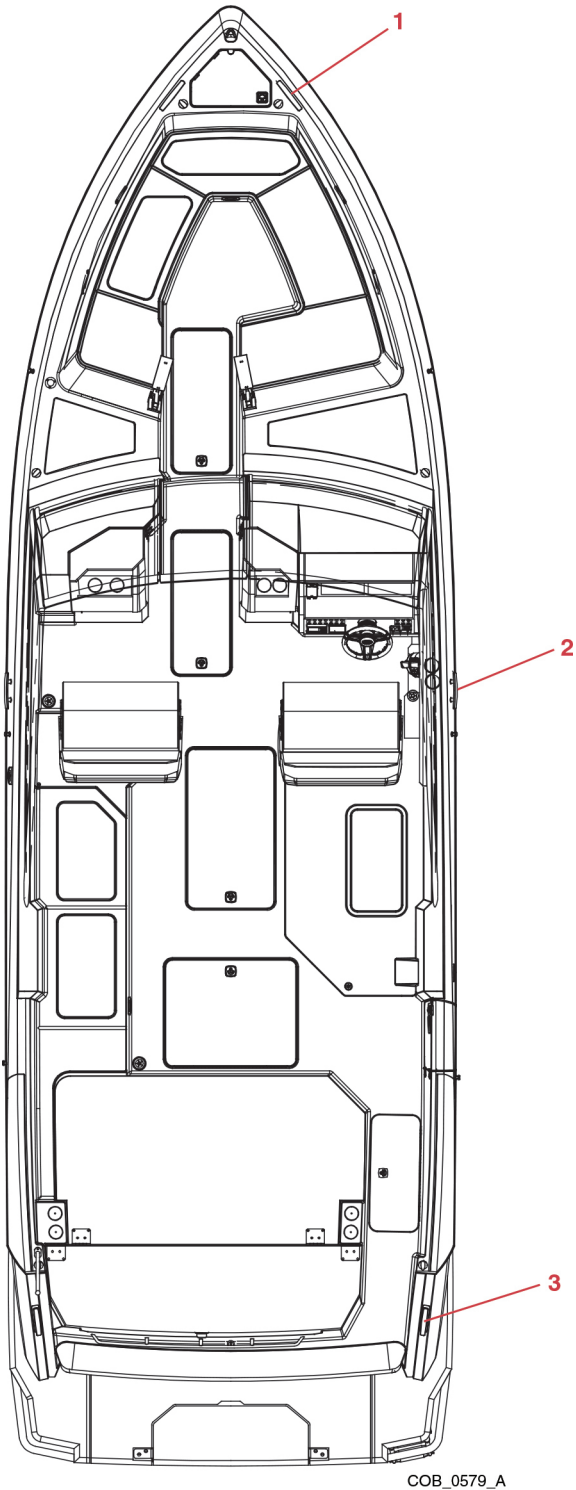

COB_0579_A

- 1 – Forward Cleat Location**
- 2 – Mid Cleat Location**
- 3 – Aft Cleat Location**

R33 Tie-Down Locations

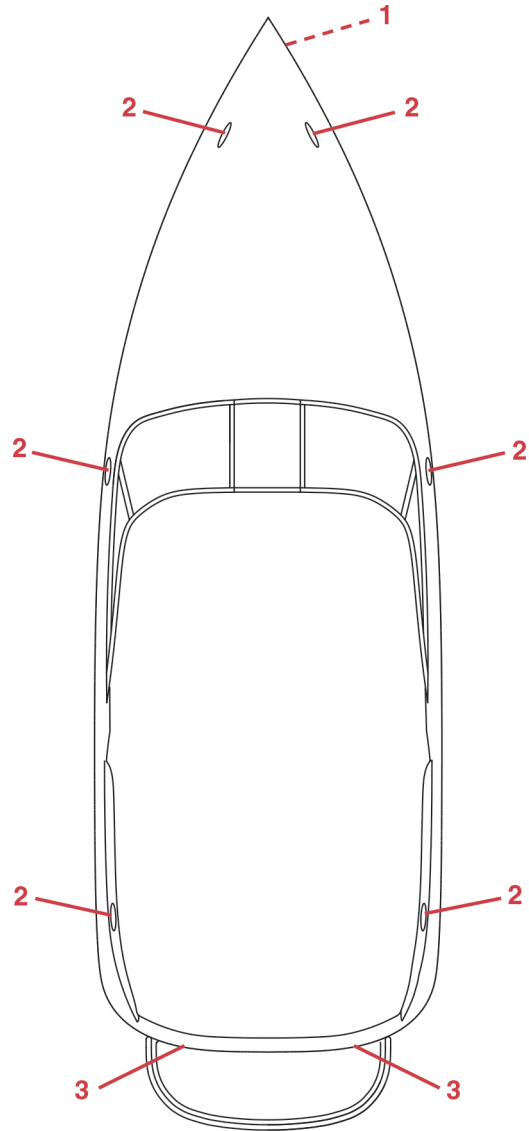

COB_0001_A

- 1 – Bow Eye**
- 2 – Cleats**
- 3 – Stern Eyes**

R30, R35 Tie-Down Locations

Tie-down locations are for keeping a Cobalt boat secured when moored. The bow eye and/or stern eyes can also be used. Refer to Anchoring, in this owner's manual.

Several methods of securing boats to shoreline and docks are available.

Although Cobalt does not provide rope for tie-ups as a standard provision, dock lines are available through many marine retailers.

Without guarantee, Cobalt recommends a two-strand nylon rope. (Three-strand rope may stretch too much and allow the boat to bump other objects.)

There are several different knots and hitches to secure boats to docks or shoreline. Cobalt recommends making the effort to learn these marine-intended knots and hitches. Consult with

your authorized Cobalt dealer to determine which ones will work best in the tie-up application you will be using.

Some hitches are intended for only short-term docking, while others work better for longer periods of inactivity. Always bear in mind wave action may cause the boat to bump the shoreline (and scratch the hull, which is not covered under warranty), or bump against a dock, or even potentially other boats (also not covered under warranty), when selecting the appropriate method to secure the boat.



Windlass/Anchor

When used to moor underwater, the anchor must be secured with an anchor snubber (clip, shackle, or other part with a short piece of line) when it is stored to prevent accidental deployment. When the anchor is deployed and in use, the rode (rope or chain) must be secured to a secure holding point. **DO NOT** use the windlass to restrain the vessel.

Be cautious when using the anchor. It may be necessary to have an observer. In some situations, the chain may need to be moved from under the windlass to prevent jamming.

DO NOT use the anchor or windlass for tie-ups to the dock or shore! Such activity does not secure the boat or prevent potentially damaging contact with docks or other objects on shore. Such damage is not covered under warranty.

NOTE: ON OCCASION, YOU MAY HAVE TO CLEAR THE PILE OF ROPE FROM UNDER THE HAWSE PIPE TO MAKE ROOM FOR THE REMAINING RODE.



Bow Eye

All boats are equipped with a single bow eye near the apex of the hull under the bow. The semi-circular or U-shaped metal connection is made from stainless steel to reduce the effects of rust and corrosion. Except for cleats, which are used in conjunction with the bow eye, no other part of the boat, including any interior components such as the windshield extrusions or grab handles should ever be used for tying up the boat.

NOTICE

Never tie up the boat, even temporarily, using any component of the boat except the bow eye and/or cleats (where equipped). Using any other component could result in damage to the boat that is not covered under warranty.



Cleats



Cleats are located near the bow on each side of the deck, mid-ship, and near both rear sides.

Although there are multiple marine knots, the cleat hitch is a special knot used to tie the rope to a cleat. If a line is not correctly secured on the cleat using a cleat hitch, it can work loose.

Cleats have two “horns” around which the line is tied. Begin by bringing the line past the center of the cleat on the outside beneath and wrap it around under both horns. Then bring the line across and back under the first horn again in a figure-eight. Make another figure-eight loop around the second horn.

WARNING

Cleats are used to tie the boat to a dock or to hang fenders. They are not designed for any kind of towing, including other boats. Nor should they be used for anchoring, mooring or lifting the boat; the only locations structurally certified for such “strong point” requirements are the bow and stern eyes. Abuse of the cleats is likely to result in equipment failure that will damage the boat, which is not covered under warranty, and can also result in serious injury or death.

NOTICE

Cobalt recommends the purchase and use of fenders to protect the boat's gel coat finish whenever a boat is at risk of contact with docks or any other object (for example, rafting up with other boats) that may damage the finish. This kind of damage is not covered under warranty.

If the boat will be moored for an extended period or where there is active wave motion, Cobalt recommends the purchase of fenders, also available from reputable marine suppliers. Fenders come in a range of sizes and materials, with the goal to protect the boat from damage because of motion against the dock.

WARNING

Never anchor a boat from the stern. Keep the boat headed into waves.

ON AND UNDER THE WATER

Beneath the boat are several critical components for the proper and safe operation of the boat. In general, consumers do not have to give these items attention beyond routine checks and maintenance, but if any of them are damaged, it can result in a truncated outing.



Propeller

Different conditions, including altitude or specific characteristics of individual bodies of water can impact boating enjoyment. If environmental conditions are suspected of negatively impacting performance, discuss this with an authorized Cobalt dealer, who may be able to recommend minor changes to the propeller, or replacement of a propeller at the consumer's choice and expense, that will improve circumstances for that application. There are limits to changes that are approved by Cobalt engineers. Changes that exceed those standards will void the warranty. Extreme changes can also alter the safe handling of the boat and its maneuverability.

NOTICE

Consumers may choose to change characteristics of propellers or even replace them. Cobalt recommends doing so only after consulting with an authorized Cobalt dealer as exceeding Cobalt standards for the propulsion system will void the warranty.

WARNING

Care must be taken to avoid being in the water forward or aft of the boat when the engine is running, even if the boat is not in a moving gear. If the shifter/throttle goes into gear, there may not be time to get out of the way of the propeller. Boat drifting can also put individuals in harm's way. Propeller edges are sharp. With motion, propellers can maim or become lethal.



Reboarding Methods

Depending on the specific boat, the means of reboarding from the water may be by use of a ladder, flip-down step, or swim platform that is close to the water and the person can climb aboard. Refer to appropriate instructions on each application for more information. If you have questions, contact your Cobalt dealer.

DANGER

DO NOT occupy the platform or use the ladder when the engine is running or engaged. Propeller contact or exposure to carbon monoxide (CO) can cause severe injury or death. All gasoline engines produce CO. It is colorless, odorless and

dangerous. Direct and prolonged exposure to CO will cause brain damage or death. The sterndrive unit and the propeller also have many sharp edges.



Swim Platform and Boarding Ladder—Optional

Certain Cobalt models are equipped with a swim platform and boarding ladder. The swim platform provides additional enjoyment of the Cobalt experience. While the swim platform, along with the optional flip-down step, can ease movement in and out of the water, Cobalt reminds users to exercise caution. When jumping off the boat, always be certain that there is sufficient depth. Appearances can be deceptive, especially in clear water. When using the ladders, use the steps with care to avoid slipping or falling.

Although the swim platform is constructed with anti-skid properties, it is still the responsibility of users to exercise care when walking on it, using it to get onboard, using it to get into the cockpit, standing or sitting on the swim board.

As noted, multiple times throughout this owner's manual, never allow anyone to be on the swim platform when the engine is running, due to exhaust fumes.

To deploy the boarding ladder:

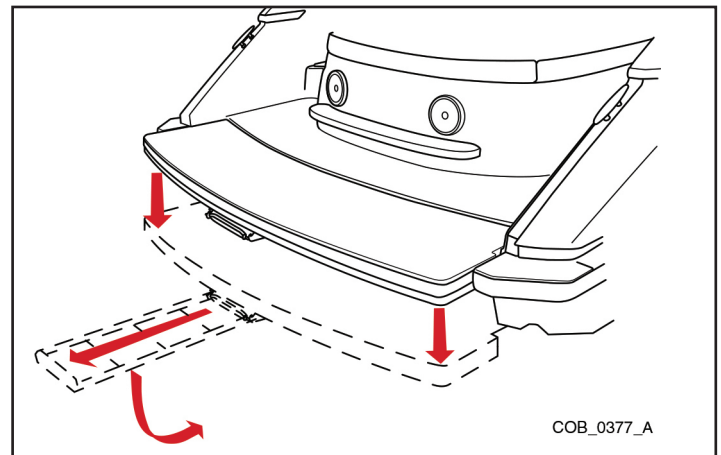

Push the telescoping ladder forward to compress the spring, and then down to remove from the latch. Pull the ladder aft and down to extend and climb aboard. Be especially careful to avoid pinching fingers, hands or other body parts in any of the moving components.

To stow the boarding ladder:

Pull up and forward on the steps to slide the ladder into the stowed position. Lift up to lock into place. Again, avoid pinching fingers, hands or other body parts in any of the moving components.

WARNING

Care should always be taken when entering or exiting the boat. The flip step is the recommended egress when the boat is

launched in water, and it should be used **ONLY** when the boat is stopped, and the engine is **OFF**. Using the gunwales for egress is highly discouraged under any circumstances.

 **WARNING**

Exercise care when deploying the flip step. Under no circumstances should anyone be standing, sitting, or laying on the step while it is in operation. In addition to possibly damaging equipment, persons on the flip step are subject to serious injury from pinching or falling. Prior to operating the flip step, the user needs to confirm that everyone's hands or feet are clear of the step's mechanical components.

 **DANGER**

Never allow anyone to be on the swim platform or flip step when the engine is running. Carbon monoxide fumes are colorless and odorless. Illness and/or death are likely from breathing fumes, even before a person is aware of exposure. See the Safety section of this owner's manual for more information regarding this critical matter.

 **DANGER**

Care must be taken to avoid being in the water forward or aft of the boat when the engine is running, even if the boat is not in a moving gear. If the shifter/throttle goes into gear, there may not be time to get out of the way of the propeller. Boat drifting can also put individuals in harm's way. Propeller edges are sharp. With motion, propellers can maim or become lethal.



Hydraulic Swim Platform

 **WARNING**

Read and follow all safety precautions. Always ensure that no person or object is near or under the swim platform before raising or lowering it. Never allow anyone to be on the swim platform while the boat is in motion. The swim platform is not designed to lift or lower people. Allowing people to be on the platform while it is in motion may result in serious bodily injury or death.

 **CAUTION**

The outdrive of the engine will automatically fully lower when the swim platform is lowered. The operator must ensure there is proper clearance below the outdrive before lowering the swim platform. Damage resulting from the outdrive striking the ground or objects is not covered under warranty.

The hydraulic swim platform was designed for use by people—not for the storage of personal equipment. The maximum platform weight capacity is 600 lbs. (272 kg).

To lower the swim platform:

1. Turn all battery switches to the **ON** position.
2. If the engine is running, turn it **OFF** before proceeding. **DO NOT** start the engine.
3. Turn the ignition key to the **OFF** position. Ensure the engine is **NOT** running.
4. Visually check to see that no person or object is near or under the swim platform. Also check for clearance below the outdrive. The outdrive will tilt down automatically when the swim platform is lowered.
5. Hold the swim platform rocker switch in the **DOWN** position.

 **CAUTION**

A warning tone emitting from the engine compartment will alert occupants that the swim platform is in motion. After the rocker switch is activated, there is a safety delay of three (3) seconds. The swim platform may be stopped and used in any position.

 **CAUTION**

In the event of an emergency, the boat may be started with the swim platform down to all the captain to idle the boat out of danger. Under normal use, the engine should **NEVER** be started without the swim platform first being raised to the **HOME** position.

To raise the swim platform:

1. Turn all battery switches to the **ON** position.
2. Turn the ignition key to **OFF**.
3. Visually check to ensure that no people or objects are near or under the swim platform.
4. Hold the swim platform rocker switch in the **UP** position.

 **CAUTION**

A warning tone emitting from the engine compartment will alert occupants that the swim platform is in motion. After the rocker switch is activated, there is a safety delay of three (3) seconds. The swim platform may be stopped and used in any position.

 **DANGER**

DO NOT occupy the platform or use the ladder when the engine is running or engaged. Propeller contact or exposure to carbon monoxide (CO) can cause severe injury or death. All gasoline engines produce CO. It is colorless, odorless and dangerous. Direct and prolonged exposure to CO will cause brain damage or death. The sterndrive unit and the propeller also have many sharp edges.



Swim Step—Flip Down

The optional flip-down step can ease movement in and out of the water, but users should exercise caution with its use. When using the step take care to avoid slipping or falling. Be certain the optional flip step is properly stowed before operating the boat. The flip step should be down (and usable) only when the boat is anchored or stationary.

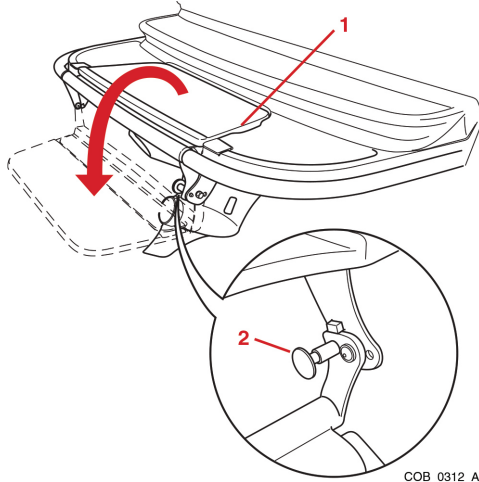

1 – Swim Step
2 – Plunger

Boat in the Water

Lower the drive all the way.

To deploy the step:

1. Pull the plunger out and pull up on the front of the step at the same time.
2. Pull the step over into the water. The step will be buoyant.
3. Push the step down; it will automatically lock into place.

To raise the step:

1. Push down slightly on the step with your feet while sitting on the platform.
2. Pull the plunger and allow the step to float up.
3. Move to the side and pull the step onto the platform. It will automatically lock into place.

Boat on a Trailer

Lower the drive as low as possible without hitting the ground or trailer.

To deploy the step:

1. Stand behind the platform; pull the plunger out and pull up on the front of the step at the same time.
2. Pull the step towards you; do not let go.
3. Gently let the step down; it will lock into place automatically.

To raise the step:

1. Pull the plunger and raise the step at the same time. Be careful when folding the step over onto the platform. Do not allow the step to slam down.
2. Always make sure the area in the platform is clear before closing the step.

WARNING

DO NOT overload the flip down swim step. The swim step maximum load is 400 lbs (181 kg).

CAUTION

The flip step must be in the stowed position whenever the boat is underway.

WARNING

Care should always be taken when entering or exiting the boat. The flip step is the recommended egress when the boat is launched in water, and it should be used **ONLY** when the boat is stopped, and the engine is OFF. Using the gunwales for egress is highly discouraged under any circumstances.

WARNING

Exercise care when deploying the flip step. Under no circumstances should anyone be standing, sitting, or laying on the step while it is in operation. In addition to possibly damaging equipment, persons on the flip step are subject to serious injury from pinching or falling. Prior to operating the flip step, the user needs to confirm that everyone's hands or feet are clear of the step's mechanical components.

DANGER

Never allow anyone to be on the swim platform or flip step when the engine is running. Carbon monoxide fumes are colorless and odorless. Illness and/or death are likely from breathing fumes, even before a person is aware of exposure. See the Safety section of this owner's manual for more information regarding this critical matter.

DANGER

Care must be taken to avoid being in the water forward or aft of the boat when the engine is running, even if the boat is not in a moving gear. If the shifter/throttle goes into gear, there may not be time to get out of the way of the propeller. Boat drifting can also put individuals in harm's way. Propeller edges are sharp. With motion, propellers can maim or become lethal.



Volvo Penta Ocean Series Outdrive—Optional

Your boat may be equipped with an Ocean Series Outdrive from Volvo Penta. In addition to a composite outdrive, there is a Neutra-Salt switch located in the helm area of your Cobalt boat. Please refer to the *Neutra-Salt Operator's Manual* located in your new owner's packet for operating information.

PERFORMANCE BOOSTS

Cruise Control—Optional



DO NOT use the cruise control feature as a means for navigation or for “no hands” operation.

To operate the Cruise Control speed control system, prepare to set when the boat gets to the desired speed. After the boat reaches the set speed, the Cruise Control will hold the speed constant. For additional operating information, refer to the Cruise Control operator’s manual in the owner’s packet.



Wake Surf Controls

Where equipped with the Surf package, the system operates as follows:

1. On either video screen, tap the **HOME** button.
2. Select the **A/V GAUGES CONTROLS** button.
3. Tap the **SURF CONTROLS** button. The Wake Surf Controls screen will be displayed. (Note that the Wake Surf Controls screen can also be accessed through *Smart Mode*.)

Functions that are performed in any mode:

- At 14 MPH, the Surf Gates will fully retract and operation will be disabled until the boat’s speed drops back below 13 MPH.
- If communication with the GPS speed is lost, a message will be displayed on the Garmin screens. The system will perform as if the boat is over 14 MPH until the GPS speed communication is reestablished. This can happen if the GPS signal is blocked by items such as roofs or buildings.
- When communication with the engine is lost, **SURF RIGHT** and **SURF LEFT** will be disabled.
- In the event of an over-current (too much electrical current) or if the controller detects a failure in the control of the Surf Gates, a corresponding fault message will be displayed on the Garmin screen. When this happens, proceed with caution as the Surf Gates are in an unknown position and can cause excessive boat angles at speeds over 14 MPH.
- The system can be reset by cycling the ignition key to the **OFF** position, waiting for the boat to power down, and then keying back **ON**.

Manual mode:

The system always powers up in Manual mode. If no other mode is active, the system will be in Manual mode.

In this mode, there is no automatic movement other than



the 14 MPH threshold that will cause the Surf Gates to retract if they were in the extended position.

Wake Surf Operation, Surf Left:

- The operator turns on Speed Control by pressing and relating “Speed Control.”
- The operator presses and releases the **SURF LEFT** momentary switch. The system enters **SURF LEFT** mode if the speed control is set to less than 14 MPH. The **SURF LEFT** indicator light will blink will the Surf Gates and engine trim are being commanded to move.
- After the Surf Gates and engine trim have stopped moving, the **SURF LEFT** indicator light will come on solid until the next movement is commanded.
- **SURF LEFT** mode stays active until the **SURF LEFT** button is pressed again or another mode is selected. The following sequence is initialized:
 1. **SURF LEFT** indicator light beings flashing.
 2. The engine trip goes into the surf position.
 3. If the speed is between 8 and 14 MPH:
 - a. The right Surf Gate extends.
 - b. The left Surf Gate retracts.
 - c. The **SURF LEFT** indicator light becomes solid until a new mode is selected or further movement of the Surf Gate or engine trim is commanded.
 4. After the GPS speed reaches 14 MPH, both Surf Gates retract.
 5. After the GPS speed drops below 13 MPH, the system reinitiates, placing the Surf Gate and entire trim back into the **SURF LEFT** position.
 6. After the GPS speed drops below 8 MPH, both Surf Gates retract.
 7. **SURF LEFT** pushed a second time will cause both

SURF Gates to fully retract. At this point, the system will be in Manual mode.

8. SURF LEFT indicator light beings flashing.
9. The engine trip goes into the surf position.
10. If the speed is between 8 and 14 MPH:
 - a. The right Surf Gate extends.
 - b. The left Surf Gate retracts.
 - c. The SURF LEFT indicator light becomes solid until a new mode is selected or further movement of the Surf Gate or engine trim is commanded.
11. After the GPS speed reaches 14 MPH, both Surf Gates retract.
12. After the GPS speed drops below 13 MPH, the system reinitiates, placing the Surf Gate and entire trim back into the SURF LEFT position.
13. After the GPS speed drops below 8 MPH, both Surf Gates retract.
14. SURF LEFT pushed a second time will cause both Surf Gates to fully retract. At this point, the system will be in Manual mode.

Wake Surf Operation, Surf Right:

- The operator turns on Speed Control by pressing and relating “Speed Control.”
- The operator presses and releases the SURF RIGHT momentary switch. The system enters SURF RIGHT mode if the speed control is set to less than 14 MPH. The SURF RIGHT indicator light will blink will the Surf Gates and engine trim are being commanded to move.
- After the Surf Gates and engine trim have stopped moving, the SURF RIGHT indicator light will come on solid until the next movement is commanded.
- SURF RIGHT mode stays active until the SURF RIGHT button is pressed again or another mode is selected. The following sequence is initialized:
 15. SURF RIGHT indicator light beings flashing.
 16. The engine trip goes into the surf position.
 17. If the speed is between 8 and 14 MPH:
 - a. The left Surf Gate extends.
 - b. The right Surf Gate retracts.
 - c. The SURF RIGHT indicator light becomes solid until a new mode is selected or further movement of the Surf Gate or engine trim is commanded.
 18. After the GPS speed reaches 14 MPH, both Surf Gates retract.
 19. After the GPS speed drops below 13 MPH, the system reinitiates, placing the Surf Gate and entire trim back into the SURF RIGHT position.
 20. After the GPS speed drops below 8 MPH, both Surf Gates retract.
 21. SURF RIGHT pushed a second time will cause both Surf Gates to fully retract. At this point, the system will be in Manual mode.

Rider Profiles:

- The operator presses and releases the Rider Profile tab in the upper right corner of the screen.
- The operator selects the profile to be activated.
- The system will configure the boat to match the settings stored for that Rider Profile.
- Ride Profiles can be edited and saved through the Settings.
- The Rider Profiles can also be edited and saved by physically configuring the boat to the desired settings and then holding the Rider Profile tab for approximately five (5) seconds. Follow the instructions in the pop-up that appears.
- If any settings are modified that cause the system to deviate from the selected Rider Profile, the Rider Profile will become inactive and place the system in Manual mode with the current manual settings.



Motor Box Assembly



DO NOT occupy or operate an engine when the motor box is open. The motor box assembly is a machinery guard.



The motor cover is substantial and may require more than one person to lift. When lifting the box manually, position one person at each grab handle and lift straight up and then place the support into position.

Do not operate the motor box assembly if the ski tow pylon is installed. Damage to the motor box, hinges, ski tow and lifting unit can result. Before opening the motor box, make sure the ski tow is removed, no items are on top of the motor box, and cushions, inserts or stored equipment are secure or removed.

Use the motor box support, which is internally attached, to brace the box after it is open. Be sure to return the support back to the stow position and clear any obstructions before closing the box. Wind and conditions may allow the motor box to open beyond its intended opening; use caution during these conditions.

The electric motor box assembly is controlled by its switch in the aft walk-thru. In the event of battery failure or storage, the motor box can be opened manually. The jump-start studs can also be used to raise or lower the motor box when batteries are low or removed. Use an auxiliary battery source such as a battery pack, jumper cables, battery charger or boost battery.



Transom Tilt Switch—Optional

The remote transom tilt switch allows the drive unit to be raised or lowered from the stern. The remote tilt switch is connected directly to the battery switch and does not require the ignition key to be ON. If the boat has twin engines, each drive unit will have a switch.



COB_0151



Seakeeper—Optional

The Seakeeper system eliminates up to 95% of boat roll. The Seakeeper system is controlled through the Garmin screens.

- Before activating the Seakeeper system, ensure the sea-cock is open.
- Open the Seakeeper Control on the Garmin screen by accessing the “OneHelm/AV Gauge” page and selecting the Seakeeper icon to bring up the controls.
- When the Seakeeper Control is open on the Garmin screen, you can control the system through the control page.

NOTICE

It takes approximately 24 minutes for the system to spool up to activation/operation speed, and 35 minutes to spool up to full power.



Tool Kit—Optional

Unanticipated issues can arise during an outing. To be prepared for minor mechanical and electrical problems an optional tool kit holds the most-likely tools to be needed. For the location of the tool kit, refer to *Specifications*.

COMFORT AND ENHANCEMENTS

Seating

Cobalt provides seating to increase your boating pleasure. The standard seating is crafted from top-quality materials and engineered to provide the maximum-allowed number of individuals onboard for the boat model’s design. Please note that it is very important for passengers to be seated when the boat is underway as shown in the seating information in Specifications in this owner’s manual. This provides for balance and avoidance of over-loading that could otherwise adversely affect the boat’s maneuverability, swamp the boat, or even cause injury or death.



Failure to evenly distribute the combination of passengers and additional gear brought onboard can result in loss of control of the boat, swamping and sinking, and causing other adverse effects. Never exceed the boat capacity, paying particular attention to limits in bow seating. Failure to pay on-going attention to this can result in serious injury or death.



Never attempt to jump into the body of water from any of the seating in the boat. It can be difficult to determine water depth, and it could be possible to misjudge clearance of the deck and gunwales.

Transom seating is intended for use only when the boat is



fully stopped, without the engine running. Sitting in this area while the boat is underway could result in individuals falling off, which could result in injury or even death. It is also possible that carbon monoxide fumes from the exhaust system could reach individuals sitting here.

On some models, the cockpit seat back can be placed fore to create a sun deck or lounge chair for two. Be sure to clear the sun deck and return it to the aft position before getting underway.

No one should sit or ride on the sun pads when the boat engine is running. Unless the boat is equipped with and

using the optional Captain's Call Exhaust system, carbon monoxide is emitted from the exhaust system and vented into the water beneath the transom. Fumes can and do reach the sun pad area. Avoidance of carbon monoxide poisoning is addressed in the *Safety* section of this manual.

⚠ WARNING

The transom seating should never be used while the boat is underway as passengers in those seats could be dislodged, resulting in injury or death. Also, the seat should never be used when the engine is running because passengers at the transom may also be subject to carbon monoxide fumes emitted from the engine(s). Do not have the engine(s) running while passengers are sitting in the transom seats. Even while stationary, the transom seats should never be the location from which individuals attempt to leap into the water. It can be difficult to determine the water depth, and people can misjudge clearance of the deck and gunwales or transom.

⚠ WARNING

Interior grab handles may be used by passengers to hold on to during boat operation. The handles are sturdy surfaces, which means that if an individual makes sharp contact with a grab handle, bruising may result. If the boat is being operated in a manner that results in excessive movement of the passengers, or if people are shoving each other, even playfully, at any time, injury is possible. Cobalt strongly recommends that this kind of activity always be avoided. Do not use the handles to secure or tie up the boat as this can cause damage that is not covered by warranty.



The passenger seat opposite the helm seat can be placed fore or aft to allow the passenger to look forward or behind the boat to observe water activities. This can also allow the cockpit seating to convert the passenger seat into part of the lounge area.

Apply forward pressure to the seat back to move the seat forward for aft viewing. To return the seat back for forward viewing, move the back into position.

⚠ WARNING

Several seating backs and/or cushions are adjustable or movable. These features operate with latches and slides. Care should always be taken to avoid pinching skin or limbs when moving components of the seating. Ensure that the various moving parts have locked into place before use. Otherwise, these components could move when people are not expecting motion, and that could result in accidentally shifting individuals.

It is critical to the long-term use and enjoyment of the boat to perform the routine maintenance required to keep all interior upholstery in top condition.



Captain's Chair Adjustments and Operation

The captain's chair has a flip-up bolster for greater visibility and maneuverability while docking. You can sit on the raised cushion or stand in front of the cushion.

Standing while driving your boat should be done only by an experienced driver while maneuvering at an idle speed or when required for visibility.

The chairs are adjustable fore and aft. Lift the lever to free the seat to move. Be sure the lever is back in secure, locked position before the boat begins any movement. If it is not secure, the seat could move while the boat is underway, and such motion could cause the operator to lose control of the vessel.

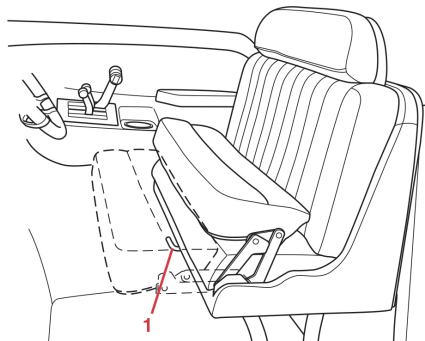

1 – Lever

COB_0091_A

Move the chair slightly forward, then lift the rotation lever to adjust. The lever will rest in its detent when the seat is in its forward direction.



DO NOT stand while driving above engine idle speeds unless required for visibility, and make sure all passengers are seated and seats are in a locked/secured position when the boat is underway. Situations may arise while underway that could cause the operator to lose footing and fall or step away from the helm, which may result in loss of control of the vessel.



Helm Seat Electric Slide Operation—Optional

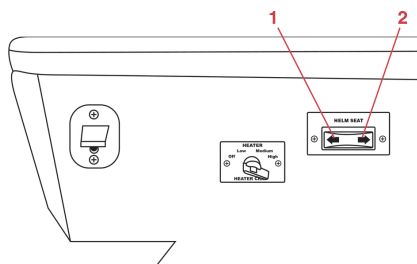

1 – Forward Switch
2 – Aft Switch

COB_0580_A

To use the electric slide, press and hold down the rocker switch in the forward position (1) to move the helm seat forward.

Press and hold down the rocker switch in the aft position (2) to move the helm seat backward.



Above engine idle speeds, be sure all passengers are seated and the seats are in a locked/secure position when the boat is underway.



Removable Bow Filler Cushion—Optional

Additional bow seating can be added by inserting the bow filler cushion. Place the cushion into position by sliding the cushion support under the bow seat, then slide the bow cushion in and push into position. When not in use, store the bow filler cushion and support in a clean and dry location.



Removable Cabin Filler Cushion—Optional

To keep the removable cabin filler cushion secure, fold up the cabin filler supports in position. Open the cabin filler storage door and slide out the cushion. lock the cushion into place by using the black lever lock as shown.



Cabin Access Door



All gasoline and diesel engines, along with fuel-burning appliances such as heaters, stoves and generators, produce carbon monoxide (CO). It is a colorless, odorless, and dangerous gas. Direct and prolonged exposure to CO will cause brain damage or death. Signs of exposure to CO include nausea, dizziness, drowsiness, ringing ears, headaches, unconsciousness and bright red skin color. Avoid exposing everyone on-board to CO. Test the carbon monoxide detector operation before each trip, at least once a week, and after the boat has been in storage. **DO NOT tamper with the operation of the CO detector. It is installed for your safety.**

The cabin access door should not be open when the boat is underway as an open cabin door can create a vacuum. Be sure the door is secured when it opened or closed, and **DO NOT allow it to swing freely.**



Secure the door when underway. Do not sit, stand or place heavy objects on the door. Unlock and remove the key to avoid breaking, unless leaving the boat.



Glove Box

Cobalt recommends storing this manual in the glove box so that it will always be readily available for reference during outings. Placing this manual in a plastic bag will increase its protection.

The glove box is convenient for storing personal items while boating, as well. While the glove box is not waterproof, its design reduces the likelihood of damage from water that may come onboard. Cobalt does not warrant the level of water resistance available when using the glove box.

The glove box opens by pushing on the button on the front of the lid. Closing requires only shutting the lid tight. Closing requires minimal effort. If more effort is required,



it is likely the glove box is overloaded, and some material should be removed prior to closing.

Do not store any aerosol items in the glove box. These can overheat and leak and/or rupture. Any liquid or semi-liquid material placed in the glove box may spill or overheat. Care should always be used when placing liquids such as suntan lotion in the glove box. Cobalt is not responsible for such misjudgments.

If any water intrudes into the glove box, clean it out as soon as practical. Mold and mildew can result if even small amounts of water are not removed. As with any storage location, any spills should be cleaned efficiently to avoid damage and/or odors.

NOTICE

Never attempt to close an overloaded glove box. Trying to force the lid closed could result in damage that is not covered under warranty. Avoid pinching fingers, hands, and other body parts while closing the glove box lid.



Storage Compartments

Cobalt boats have multiple storage compartments available throughout the boat. In general, storage is available in the bow, gunwale, and floor. Some models will also have transom storage and may have interior lighting within the storage compartments.

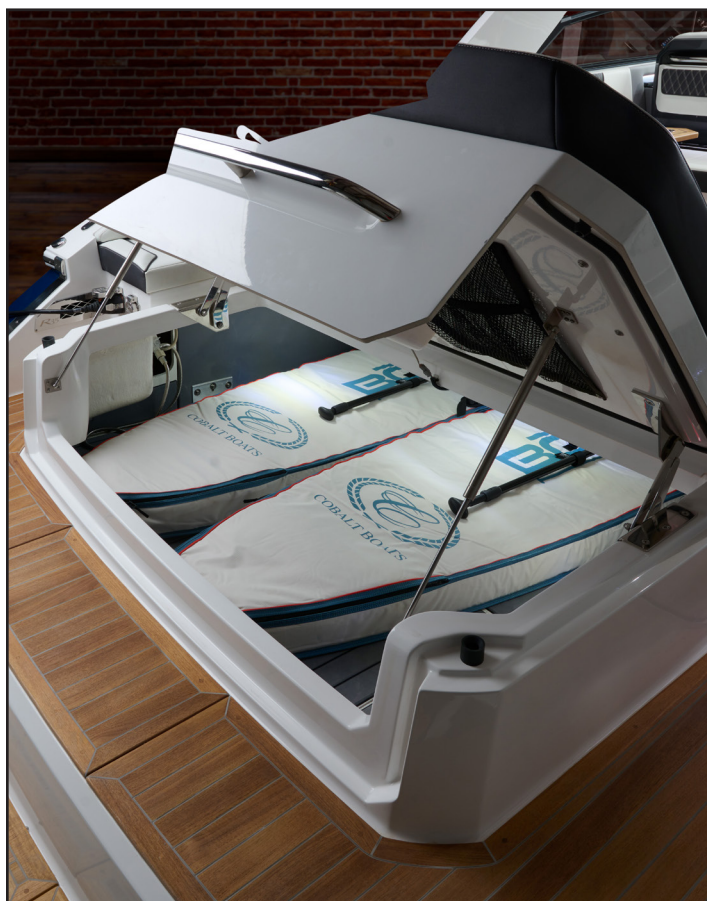

As much as possible, gear and property brought onboard should be stowed in storage compartments to prevent movement of items during the outing. Unsecured items could strike and potentially injure individuals onboard during operation.

Be sure to distribute items throughout the boat and compensate for the weight of persons onboard. Weight should be as evenly distributed throughout the boat as possible to avoid negatively affecting control. Never try to close an overloaded storage compartment. Forcing a compartment closed can result in damage to the boat that is not covered under warranty.

Storage compartments should be cleaned out in accordance with the instructions in this manual. At least annually, all compartments require thorough cleaning. If anything with residual odor is placed in a storage compartment, or if anything has spilled in the compartment, cleaning should be done as quickly as possible afterwards.



Anything brought onboard should be stored in a designated storage compartment, if possible, to avoid the potential of individuals being struck by an unsecured item while underway. This could result in serious injury or even death. Items should be evenly distributed and with attention to the number of passengers and where they will sit. Even distribution of added weight is critical to a safe operation.

Never force a compartment closed as overloading could cause damage to the boat and that is not covered under warranty.



Cup Holders

All boats are equipped with cup holders. The cup holders are sized for contemporary, normal-sized cups. Cobalt recommends using only cups with covers as boat motion is likely to otherwise slosh liquids out of the cups. If liquids are spilled into the cup holder, or anywhere else, they should be cleaned up as soon as practical to prevent any damage to the boat components or anything brought onboard. Such damage is not covered under warranty.



Windshield

The Cobalt windshield can be opened to allow easier access to the bow area and greater air flow. To open the windshield, ensure the vertical slots in the mechanism are aligned. Swing the windshield open until the windshield post falls into the vertical slots and the mechanism locks.

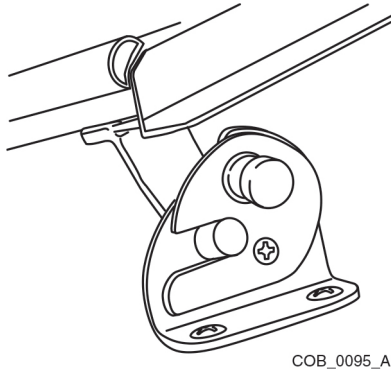

COB_0095_A

To close the windshield, release the locking mechanism by pulling the forward-facing button. Swing the windshield into the closed position.

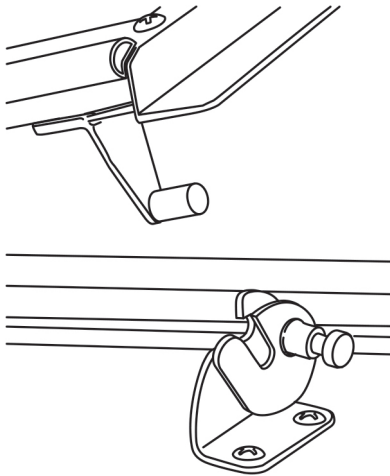

CAUTION

In the process of opening or closing the windshield, care should be taken to avoid pinching fingers, hands or any body parts between windshield sections. Injury may result.



Air Conditioning/Heating—Optional

The heating, ventilation and air conditioning (HVAC) system supplies both heating and cooling to the cabin and head by way of a heat pump system. The system operates on 110V AC supplied by shore power or the generator. The system controller is located in the cabin.

NOTICE

The boat must be in the water before operating the air conditioning/heating system.

The system must be properly winterized for storage to prevent damage. For additional information, refer to the air conditioning operating instructions in your owner's packet.

To operate the HVAC system:

- Open the seacock in the engine compartment.

- Turn ON the MAIN and AIR CONDITIONER circuit breakers located on the cabin distribution panel.
- Turn the HVAC System ON by pressing the appropriate buttons on the controller and adjust the settings as needed.

Air Conditioner Location

The air conditioner is located under the port helm seat cockpit floor. Access it through the mid cockpit floor storage compartment and removing the port access panel.



Air Conditioning 12V DC Only—Optional

Where equipped, the air conditioning system supplies cooling only (no heat) to the cabin and head, and it operates on 12V DC electricity supplied from the House battery. The system controller is located in the cabin.

NOTICE

The boat must be in the water before operating the air conditioning system.

For extended use, the engines must be running in order to charge the House battery.

The system must be properly winterized for storage to prevent damage. For additional information, refer to the air conditioning operating instructions in your owner's packet.

To operate the HVAC system:

- Open the seacock in the engine compartment.
- Turn the House battery switch ON.
- Turn the Air Conditioning system ON by pressing the appropriate buttons on the controller. Adjust the settings as needed.

Air Conditioner Location

The air conditioner is located under the bow walk-thru area. Access is through the bow ski storage access.



Cockpit Heater—Optional

A popular option is the heater. Warm air is vented to the deck from the engine core. Vent locations vary by model, so owners/operators and passengers should familiarize themselves with the locations. The vents have sliding, directional gates that can redirect the air flow, or even shut it off.

The heater is activated by a switch at the dash. The temperature is controlled by adjusting the louvered vents. The air coming through the vents may be cool initially, depending on whether the engine has warmed up. The hot water to heat the heater core is pulled from the engine. Therefore, the engine must be running to have warm air flow from the heater. Al-

low a reasonable period for the air to warm. However, if it has not warmed after several minutes, it may signal an issue with the heater system. This will require attention from an authorized Cobalt dealer.



Never operate the heater within a confined space. This includes with a canvas cover over the cockpit or bow area, with the stern of the boat in a shallow area, or at the dock/shore with other boats or docks close by. Any situation in which exhaust fumes are trapped or limited in disbursement could result in carbon monoxide fumes within the deck and could result in carbon monoxide poisoning. Carbon monoxide poisoning is addressed in the Safety section of this manual.

Be aware that operation of the heater is a drain on the battery. Review the *Electrical* section in this chapter for important information regarding how to avoid becoming stranded by a fully discharged battery or batteries. Pay attention to the voltmeter reading; whenever it falls below acceptable levels, the battery requires recharging.



Microwave—Optional

Where equipped, the microwave operates when the boat is connected to shore power (110V AC) or the optional generator is running. Energize the appropriate, marked switches on the Cabin distribution panel and the switch marked MICROWAVE.

For additional information regarding the correct usage of the microwave, refer to the operating manual provided by the manufacturer, which was provided in the owner's packet.



Cockpit BBQ Range Top—Optional

The cockpit BBQ range top runs on electrical power. In order to operate the BBQ range, the inverter power needs to be ON. The inverter power switch is located on the galley. The inverter is located in the port cockpit storage area.

For additional information, refer to the range top operator's manual in the owner's packet.



The BBQ range top surfaces can be very hot! DO NOT place the cover on the BBQ range top unless all surfaces have cooled to air temperature. DO NOT touch any hot surface as it may result in serious burns.



Refrigerator/Freezer—Optional

The refrigerator/freezer receives power from the 12V DC electrical system. The electrical system must be energized correctly at the cabin distribution panel. The 12V DC main switch must be turned on, as well as the switch marked REFRIGERATOR.

The thermostat (temperature) control is inside the refrigerator.

For additional information regarding the correct usage of the refrigerator/freezer, refer to the operating manual provided by the manufacturer, which was provided in the owner's packet.





Cockpit Dinette Table—Optional

Cobalt boats may be equipped with a cockpit table. Unless the table is locked into place, it should be stowed to avoid potentially having parts of it become projectiles during boat operation.

Access to the dinette table depends on the model and table. On some models, remove the J-shaped table leg *from the starboard bow storage area*. Slide the leg into its mounting support. Slide the tabletop onto the leg. If the tabletop has a lever, tighten the lever.

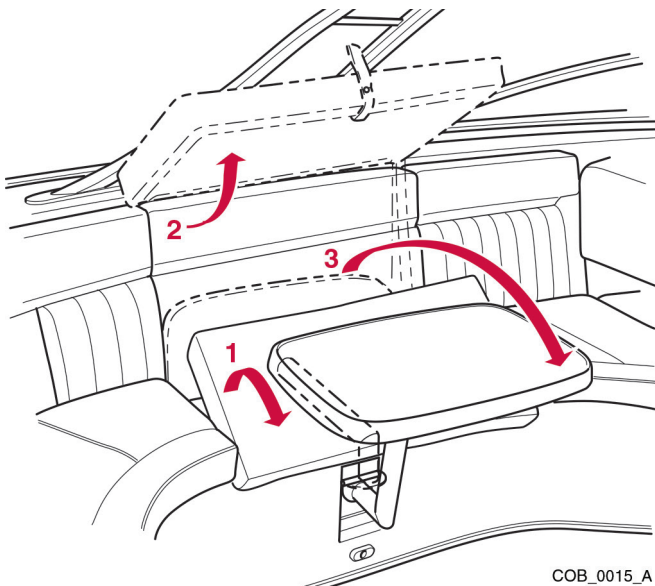

COB_0015_A

On other models, to access the cockpit dinette table, lift and remove the table seat cushion. Lift the seat back as shown to access the table. Lift the table top from its stowed position and lower the table into position. (Return the seat cushion by

placing the front of the seat cushion in position.) To return the table to its stowed position, reverse the steps just listed.

Your optional dinette table may include teak as one of the materials. Teak has been chosen because of its durability, especially in wet conditions. However, to keep teak in top condition, clean it occasionally with a teak cleaner and re-oil it at least once a season. **Do not use any other type of cleaner as it may cause damage to the table finish.** Note that all wood eventually deteriorates in the presence of damp or wet conditions, but keeping the table pieces re-oiled annually will significantly lengthen the life of the table's finish.



Cooler or Ice Chest

As a convenience, your Cobalt boat may be equipped with a cooler or ice chest. Ice can be manually added with beverages and food, and it will keep items cooled for several hours, as long as the cooler remains closed.

NOTICE

Any remaining ice or melt should be disposed of at the conclusion of the outing. Contents should also be removed. Allowing liquid to remain undrained will lead to damaging mold and mildew. Food items will spoil, and some will create an odor that cannot be eliminated, even after a thorough cleaning. Spills should also be cleaned up immediately after the outing as food and drink can permanently stain the cooler. No claims are made about stain resistance, regardless of how quickly the spillage is cleaned. Damages from misuse of the cooler are not covered under warranty.



Entertainment Components

Cabin Outlets

All boats have two (2) 110-volt receptacles in the forward storage area. Some boats do not have any label on the inverter outlet, which is the aft outlet on those boats. On other boats, the inverter outlet was moved to the front outlet, marked so that operators will note from the label that it has limited power capacity.

Inverter Location for 110-Volt Outlet in Front of the Cabin

On some boats, the inverter is located below the panel in the cabin that holds the stereo, etc. Remove the black stereo panel (six screws) and pull out. The inverter is directly below, attached to the bulkhead.

On other boats, the inverter is located forward of the pull-out cushion.

On still other models, the inverter is located in the cockpit floor storage on the front of the sealed engine compartment bulkhead. The TV and outlet use the same inverter.

An authorized Cobalt dealer can assist operators in determining which location is correct for the boat model.

Stereo Amplifiers

The stereo amplifiers are located under the helm on the bulkhead.

Stereo Head Unit/Sirius Radio Receiver

Located below the black metal panel in front of the cabin that holds the stereo equipment, removed the black stereo panel (six screws) and pull out. The unit is directly below, attached to the bulkhead.

TV Antennae Gain Control

The TV antennae gain control is located in the forward storage in the cabin, on the top left corner. The antennae are mounted to the exterior arch.

TV Inverter

On some models, the inverter for the TV is located in the cockpit floor storage on the front of the sealed engine compartment bulkhead.

On other models, the inverter is directly under the starboard forward speaker in the cabin. Access is by removing one (1) screw from the vinyl panel under the speaker.

The light will be green if the system is working correctly, and red if there is a fault.

NOTICE

Inverters have limited power output and will automatically turn off if overused. Reset the switch on the inverter or remote.



Television/Stereo

A television/stereo system is located inside the cabin, forward of the head, and operates on 12V DC.

To operate the television:

Turn on the battery MAIN and TV/STEREO switches located on the cabin distribution panel.

To turn on the power for the TV, slide the red button, located at the top right corner of the TV, to the right.

Power to the unit cannot be turned on with the remote, but can be controlled by the remote control after the power is ON.

The stereo AM/FM/CD/DVD system can also be operated by the remote. Refer to the entertainment operator's manual for complete directions. This information was provided in the owner's packet.



Air Compressor—Optional

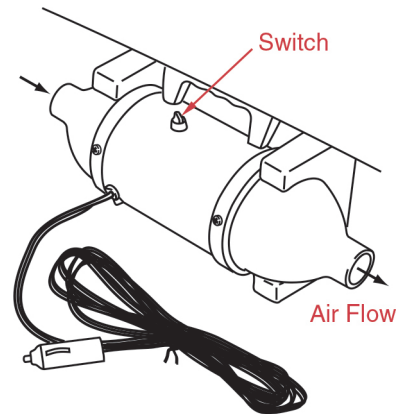

Where equipped, a high-volume air compressor is conveniently located in the *port-side bench seat storage compartment on some models. On others, it is located in the starboard aft walk-thru storage compartment.* It is used to inflate your favorite water toys. Plug into the accessory receptacle: on some models, this is located on the dash or in the air compressor area. On other models, it is in the glove box, under the starboard side dash or in the accessory receptacle in the cabin console.

Avoid direct exposure to water as the air compressor is not waterproof and can be damaged. This is not covered under warranty. Keep stowed in a dry location when not in use.



Anchor Light

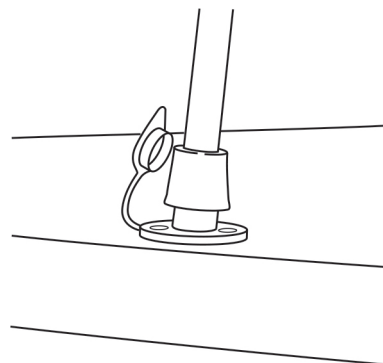

COB_0097_A

To use the anchor light, insert the pole into the socket and turn clockwise until it locks into place.



Do not put any pressure on the anchor light while it is installed as that could result in bending, breaking or otherwise damaging the light. That is not covered under warranty. Individuals could also be injured.

Close and protect the anchor light socket when the anchor light is removed by closing off the void with the attached cap.





RGB Lighting Operation—Optional

Some models have Manual Control of the RGB lighting.
To operate manually:

1. Activate the accent and underwater lights by using the dash switches.
2. When the lights come on, push and release the dimmer switch to make the lights cycle through all the colors. To select a desired color during cycling, push the dimmer switch once to lock in the color.
3. To toggle through all the colors, rapidly push the dimmer switch.
4. Pushing and holding the dimmer switch will adjust the brightness of the lighting.
5. If both the underwater and accent light switch is turned off, upon turning on again, the lights will default to white and full brightness.

On some models, the RGB accent light system is controlled through the Garmin screens:

1. *Open the Shadow-Caster Lighting Control* by accessing the Garmin Menu, and swiping left from the right side of the screen. Select the OneHelm/AV Gauge option, followed by selecting the Shadow-Caster icon to bring up controls.
2. *After the Shadow-Caster control is open on Garmin:*
 - a. If the RGB light dash switch is already ON, the lights will turn OFF the first time the Shadow-Caster Control page is launched as it takes control of the lights. Making a selection on the Shadow-Caster control page will turn the lights back ON to the mode that was selected on the control page.
 - b. If the RGB light dash switch is not ON, it must be turned ON to supply power. The lights

will initially appear white until a selection is made on the Shadow-Caster control page.

c. The operator controls the light settings for both the underwater lights and the accent lights through the Garmin screen, allowing for changing colors, brightness, and other settings. If at any point the dash switches are turned OFF and turned back ON, all the lighting will default back to white until a new selection is made on the Shadow-Caster control page.



Underwater Lights—Optional

The underwater lights have two methods of control, depending upon whether the Shadow-Caster RGB Accent option is installed or not.

- *Underwater lights without Shadow-Caster RGB Accent option:*

—Underwater lights are controlled by cycling the underwater light switch located on the dash. Cycling the switch will rotate the underwater light through its predetermined colors.

Underwater lights with Shadow-Caster RGB Accent option:

—*Open the Shadow-Caster Lighting Control* on the Garmin screen by accessing the “OneHelm/AV Gauge” page and selecting the Shadow-Caster icon to bring up the controls.

—*After the Shadow-Caster Control is open* on the Garmin screen:

a. If the RGB light dash switch is already ON, the lights will turn OFF the first time the Shadow-Caster Control page is launched as it takes control of the lights. Making a selection on the Shadow-Caster control page will turn the



flow. Allow the water to flow until those should disappear.

Water Heater Location:

The water heater is located ***under the helm seat cockpit floor***. Access it by removing the floor access lid or through the mid-cockpit floor storage compartment, and then removing the starboard access panel inside.



DO NOT smoke or have any open flame near an open faucet. Hydrogen gas is extremely flammable.



Head Shower and Sink/Transom Shower Washdown—Optional

In some models a head sink and shower are supplied with hot and cold water from the fresh water system. The water pressure breaker must be ON to supply water to the head sink and shower outlets. In some models, a shower is located under the cover at the port side transom walk-through.

To use the shower, the water pressure breaker must be on at the main distribution panel.

1. To operate, open the cover to access the shower head.
2. Pull out the knob to turn on the water.
3. Turn the knob to control the temperature of the water.



Marine Toilet (Head)

Instructions

Before operating the head for the first time, refer to the marine toilet owner's manual in the new boat owner's packet.



Porta Potti

To operate:

1. Depress the bellows pump to fill the bowl with water.
2. To flush, pull out the slide valve handle, located on the front of the unit. Depress the bellows pump one or more times until all waste is removed.
3. Close the slide valve by pushing the handle fully in.

The marine toilet (head) has its own holding tank and can be emptied manually, or if the “pump out” option is installed, the waste can be pumped out through a deck plate fitting marked WASTE, or overboard with the optional macerator and where allowed.

NOTICE

For storage or discharge, only liquids should be deposited in the toilet. Toilet paper, sanitary items, food, etc., should be placed in a separate container prepared for this purpose and disposed of in a proper location after the outing. Solid waste can clog the lines of the marine toilet system, causing a backup and potentially hazardous spillage. Many boating bodies of water also restrict waste discharge.

NOTICE

Overboard discharge of waste should be used only in areas where such discharge is legal. It is the boat owner's/operator's responsibility to comply with local regulations regarding the discharge of waste. Having an operable overboard discharge system does not mean that it can be used in spite of specific regulations regarding discharge. You could be significantly fined if the system is used in an unapproved manner. To avoid misuse, lock the “Y” valve in the “pump-out” position when boating in restricted waters.



VacuFlush Toilet System—Optional

To use the toilet system, the MAIN, HEAD and WATER PRESSURE breakers must be ON at the distribution panel.

To operate:

1. Turn on the switch located behind the toilet.
2. The red light will illuminate for approximately one (1) minute until a vacuum is created. There must also be a small amount of water in the bowl.
3. The green light will illuminate when the system is ready for operation.
4. Lift the lever for extra water if needed, and then depress the lever to flush.



Electrically Operated Head

NOTICE

Avoid damage to the waste system. Do not flush into a full holding tank.

1. Make sure the inlet seacocks are open.
2. Push the button to operate.
3. Operate until the bowl is completely flushed and the discharge pump has scavenged water from the bottom of the bowl.

The electric marine toilet will provide years of trouble-free service if properly used. It will handle waste and toilet tissue. It will NOT handle rags, sanitary items or hard, solid objects. *See the NOTICES in the previous listings regarding restrictions.*

TROUBLESHOOTING NOTE: If the bowl does not pump out as it begins to fill, partially close the inlet valve until the bowl is cleared and completely pumped out. Then operate for a few seconds with both valves open to clear the entire toilet and discharge system.

NOTICE

For maximum safety, when the toilet is not in use or the vessel is unattended, close both the inlet and discharge seacocks.

To drain for winter lay-up, close the inlet valve and operate for a few seconds until all water is pumped out. Do not leave the pump in the ON position as it will cause damage to the pump that is not covered under warranty. All water must be removed from the system prior to storage, particularly during cold weather when residual water could freeze and then damage the system.

After significant periods of non-use, the toilet and pump may dry out. To ease initial start-up, put about one (1) quart (1 L) of water in bowl and let stand before initial use.

With this option, your boat is fitted with a waste holding tank. It is emptied through the deck plate fitting marked **WASTE**. Waste is pumped from the head through a sanitary waste hose to the top portion of the tank. A sanitary waste hose is attached to the bottom of the tank and runs to the dockside pump-out plate. An overboard vent keeps the tank at atmospheric pressure regardless of waste levels.

The optional macerator system allows discharge from the waste tank directly overboard. For additional operating information, refer to the macerator operator's manual. (As noted above, direct discharge **MAY NOT** be allowed. Always verify before discharging.)

All components of the waste system are made of materials specially formulated to prevent odor permeation. It is strongly recommended you regularly add chemicals formulated for

recreational products to your tank by flushing it through the head. The chemical helps to control odor and break down the waste. Follow the manufacturer's instructions on the chemical before using. Such chemicals are available through marine distributors, RV suppliers and, in some instances, Cobalt dealers.

CAUTION

Never use harsh chemicals that have not been formulated for use in a boat head, as these can cause damage that is not covered under warranty and contact with skin could result in injury.



Dockside Waste Disposal

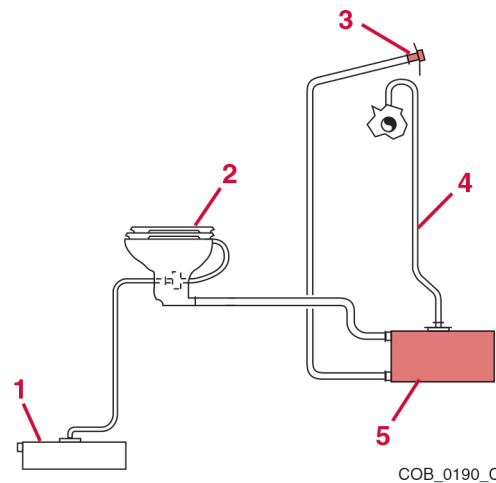

- 1 – Water Tank
- 2 – Head
- 3 – Waste Dockside Pump-out Fitting
- 4 – Vent
- 5 – Holding Tank



Dockside Pump-Out

This system directs all waste from the head to the holding tank. To clear the tank, use the dockside pump-out services provided at marinas or other facilities.

To empty the tank, connect the dockside pump suction hose to the **WASTE** pump-out plate. The **WASTE** pump-out plate is always located at a “high point” on the boat. For the **WASTE** pump-out connection, refer to Water/Plumbing.

NOTICE

Overboard discharge of waste should be used only in areas where such discharge is legal. It is the boat owner's/operator's responsibility to comply with local regulations regarding the discharge of waste. Having an operable overboard

discharge system does not mean that it can be used outside of specific regulations regarding discharge. You could be significantly fined if the system is used in an unapproved manner. To avoid a fine, lock the “Y” valve in the “pump-out” position when boating in restricted waters.



Macerator Pump

NOTICE

Overboard discharge of waste should be used only in areas where such discharge is legal. It is the boat owner’s/operator’s responsibility to comply with local regulations regarding the discharge of waste. Having an operable overboard discharge system does not mean that it can be used outside of specific regulations regarding discharge. You could be significantly fined if the system is used in an unapproved manner. To avoid a fine, lock the “Y” valve in the “pump-out” position when boating in restricted waters.

NOTICE

Avoid damaging the macerator unit. Do not run the macerator dry. Running it when there is no waste will shorten the life of the system.



Waste Disposal with Optional Macerator

The optional macerator system allows the discharging of waste directly overboard. Refer to Water/Plumbing for component location. For additional operating information refer to the macerator operator’s manual supplied with the Cobalt boat.

A “Y” valve is installed in the holding tank outlet hose and permits use of the dockside pump-out feature or to use the macerator to pump the waste from the holding tank overboard.

1. To pump out the holding tank using the macerator pump:
2. Move the “Y” valve lever to the **OVERBOARD** position.
3. Activate the macerator pump by turning the switch on.
4. Turn off the macerator pump after the pump-out is complete.
5. Move the “Y” valve lever back to the **PUMP OUT** position.

If your boat is equipped with a tank level monitor, the tank level monitor will illuminate the indicator light to monitor the tank level. If the monitor fails to work properly, seek assistance from an authorized Cobalt dealer. The monitor is critical to determining when the holding tank is becoming too full to continue using without off-loading waste.

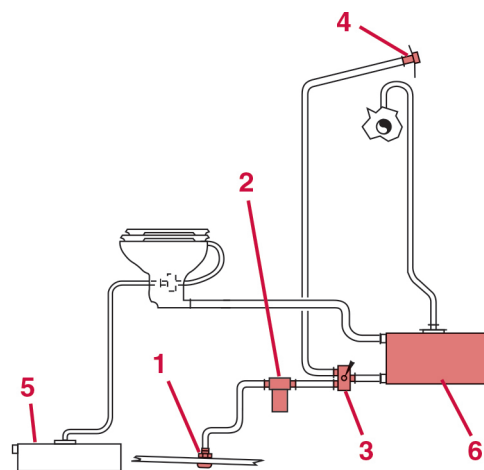

COB_0189_C

- 1 – Thru-Hull Discharge Fitting
- 2 – Macerator Pump
- 3 – “Y” Valve
- 4 – Waste Dockside Pump-out Fitting
- 5 – Water Tank
- 6 – Holding Tank

NOTICE

Overboard discharge of waste should be used only in areas where such discharge is legal. It is the boat owner’s/operator’s responsibility to comply with local regulations regarding the discharge of waste. Having an operable overboard discharge system does not mean that it can be used outside of specific regulations regarding discharge. You could be significantly fined if the system is used in an unapproved manner. To avoid a fine, lock the “Y” valve in the “pump-out” position when boating in restricted waters.



ARCHS, SPLASH & STOW™, CANVAS AND COVERS

⚠ DANGER

- Arches and towers are designed to tow a wakeboarder.
- DO NOT tow other boats, tubes, parasails, etc.
- DO NOT climb, jump or dive off an arch or tower.
- Before and during each use be sure all bolts and fasteners are tight.
- Be sure there is sufficient clearance above the arch/tower when it is up.
- Watch for bridges, power lines, tree limbs and other low-hanging obstacles.
- Failure to follow these instructions can lead to serious injury or death.

⚠ WARNING

No components should be added to the Cobalt tower or arch beyond what is specified by Cobalt. Other aftermarket items may not be acceptable due to electrical, electronic, or other wiring and power-related issues. The tower or arch weight limit may also be exceeded by adding aftermarket items. Such weight limits can also cause the tower or arch to fail, which could result in damage that is not covered under warranty, as well as serious injury or death to persons onboard. Never suspend any additional items from the tower or arch. No one should ever be allowed to sit or stand on or hang from the tower or arch. The design will not support such activity and may result in serious injury or death.

⚠ WARNING

Never sit or allow others to sit aft of the connection point for a tow rope on a tower or pylon. When the towed individual lets loose of the ski/wakeboard rope, the tension may cause the rope and its tow handle to snap back into the deck area. Individuals may not be able to deflect the rope, with the result that people hit by the rope and handle could be injured, especially if they are not paying attention.

⚠ WARNING

Secure boards and/or skis prior to operating the boat. If they are not secure, the boards and/or skis may become projectiles that could damage the boat or hurt individuals. Remove and stow items in the boat when trailering. Even if secured on the racks, highway speed can cause damage to the boards, skis, tower or boat, or even cause them to become projectiles that can hit other vehicles on the road and cause damage and/or serious injury or death.

⚠ CAUTION

Do not allow loose ropes to hang from the tower. In these instances, the ropes may become entangled with drivers, passengers or equipment. Inflatables should NOT be towed from the tower. The impact forces exerted by towed inflatables may damage the tower or the hull of the boat.



Bow Tonneau Cover—Optional

(Before using this component, be sure to read all the Danger, Warning and Caution statements at the beginning of this section.)

Follow these procedures to attach the bow tonneau cover:

1. Open the walk-thru doors.
2. Starting at the forward edge of the bow, slip the tonneau's bow opening over bow, covering to the bow adjacent to the helm, and snap the cover to the boat.
3. Close the windshield center door and snap the canvas to the underside of the windshield.
4. Install the adjustable tonneau cover support pole. Make sure the pole is perpendicular to the floor and adjust to "tent" the cover.
5. Walk-thru doors may be closed, if desired.

NOTICE

Do not use the bow tonneau cover for extended storage. It is not designed for storage but can be used for overnight storage or trailering.

NOTICE

Always double-check the snaps are secure.

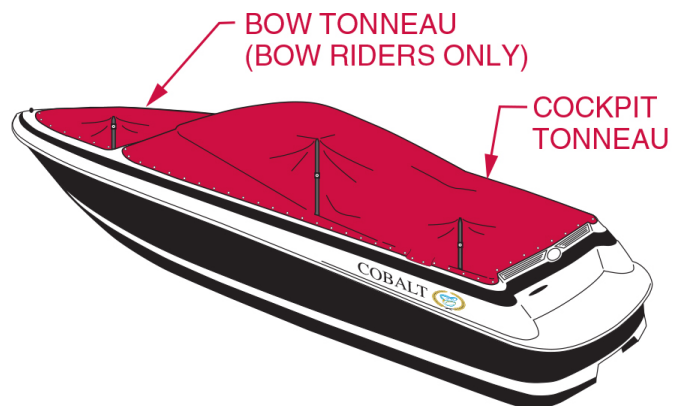

COB_0138_A

Cockpit Tonneau Cover—Optional

(Before using this component, be sure to read all the Danger, Warning and Caution statements at the beginning of this section.)

Follow these directions for the cockpit tonneau cover:

1. Unroll the cover and snap to the deck, starting at the center of the windshield. Snap to the forward outside edge of the windshield only.
2. Install tonneau support pole(s) to the underside of the cover (just in front of the rear seat) using the snaps, and adjust the pole(s) to the approximate height of the windshield. Some models have two support poles. Make sure the poles are perpendicular to the floor and adjust to “tent” the cover.
3. Pull elastic cords over the discs on the transom, starting in the center and working outboard (the support poles may require readjustment for proper fit).
4. Continue snapping up the sides.
5. The walk-thru doors may be closed, if desired.

NOTICE

Do not use cockpit tonneau cover for extended storage. It is not designed for storage, but can be used for overnight storage or trailering.

NOTICE

Always double-check snaps are secure.



Premium Bimini Top with Easy Fold—Optional

(Before using this component, be sure to read all the Danger, Warning and Caution statements at the beginning of this section.)

NOTICE

Do not operate equipment that has loose or missing fasteners. Be sure all fasteners are installed and properly tightened before operating equipment.

1. Remove the stainless adjustable arms from the storage area.
2. Unfold the top and install the stainless adjustable arms (tensioners) into the quick-disconnect fittings on the deck, forward of the windshield. Secure the forward arms to the forward cross members with the pins.
3. Tighten the Bimini by twisting the tensioners.
4. When the top is up, make sure the light wire is routed correctly and the navigation light is properly secured.

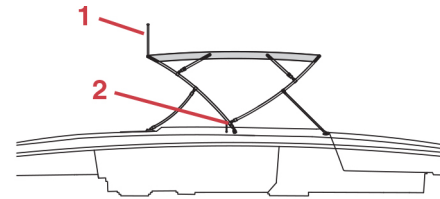

COB_0455_A

- 1 – Navigation Light
- 2 – Light Wire

5. To assist in laying the Bimini down for storage, there are four (4) knobs and lanyards in the glove box that can be installed instead of the socket-head bolts and slotted screws, if desired. Do not trailer with the Bimini top up. Store and trailer the Bimini top in the stowed position, in its canvas boot.
6. To fold down the Bimini top, release the port side lever.

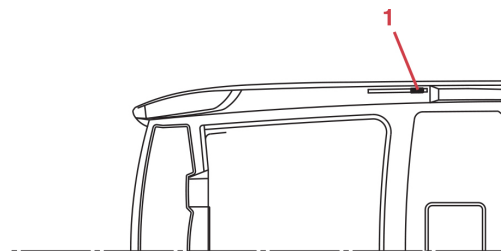

COB_0456_A

1-Port Side Lever

7. Move to the starboard side, lift up and hold the release lever and fold down the Bimini top.

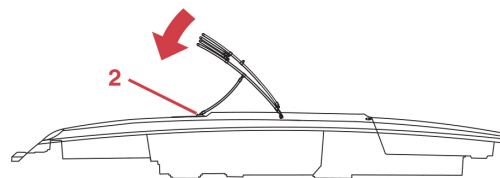

COB_0458_A

2—Release Lever

8. Once the top is folded down, secure the locking levers into the aft locking position.

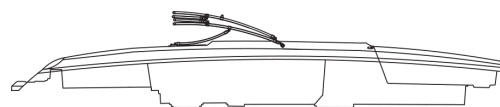

COB_0457_A

9. To deploy the Bimini top, reverse the above procedure.



Stainless Steel/Aluminum Arch with Sunshade—Optional

(Before using this component, be sure to read all the Danger, Warning and Caution statements at the beginning of this section.)

NOTICE

Do not operate equipment that has loose or missing fasteners. Be sure all fasteners are installed and properly tightened before operating equipment.

Installation

1. Position the canvas on the top side of the sunshade tube frame. The long zipper located near the ski pylon will extend the length of the boat when installed. The three forward flaps will be positioned evenly between the framing of the sunshade.
2. Open the three forward flaps and wrap the flap around the forward tube.
3. Zip. (There is a small Velcro flap for securing the zipper pull.)
4. Ensure the long zipper on the aft end of the canvas is zipped closed.
5. Locate the flaps near the center of the underside of the canvas. These flaps will align with the tubing going side-to-side on the sunshade.
6. Wrap the flaps around the tube and secure the Velcro flaps.
7. Open the three aft flaps on the canvas and locate the two straps sewn to the inside of the center flap. Unbuckle the straps. The end, sewn to the flap, will drop down below the aft side of the tube.
8. Reattach to the end, which is sewn to the underside of the canvas. This will allow tension to be pulled on the canvas as the deployment is completed.
9. Pull the canvas tight from bow to stern by rotating the canvas around the aft tube and pulling on the two aft straps.
10. Secure the Velcro flaps.
11. After the canvas is snug bow to stern, open and secure the side flaps to the outer tube framing of the sunshade. Pull the canvas tight side-to-side by rotating the flap around the tubing and securing the Velcro flap.

NOTICE

The small straps/buckles located inside the aft corner flaps should be folded up and stored inside the flap when installed. These straps are for securing the sunshade in the folded position only. Any other use could cause equipment failure, which is not covered under warranty.

Removal

1. Open all Velcro flaps.
2. Release the two aft buckle straps.
3. Unzip the flaps.



Hardtop with Manual Sureshade—Optional

(Before using this component, be sure to read all the Danger, Warning and Caution statements at the beginning of this section.)

NOTICE

Do not operate equipment that has loose or missing fasteners. Be sure all fasteners are installed and properly tightened before operating equipment.

The SureShade manual tele-frame shade utilizes a patented, telescoping tubular framework to automatically extend or retract the canvas with a simple-to-operate hand lever. Over time, the SureShade may require occasional lubricating in order to keep the hand lever functioning properly. Utilize the following steps to ensure the manual shade system will be well-maintained and fully functional for a long period of time.

1. Use a lithium grease lubricant (such as WD-40) to alleviate any issues with extending or retracting the shade using the hand lever. Be very careful to avoid getting the lubricant on any other surfaces, especially canvas or upholstery. If any does get on other surfaces, clean immediately as directed in the Care and Maintenance section of this owner's manual.
2. On the port side canvas roller clamp, there is a black plastic bushing where the roller shaft turns. Add lubricant between the bushing and the roller shaft.
3. If cranking issues persist, ensure that the canvas is centered on the roller. The canvas can potentially shift over time, and this could also contribute to difficulty in the SureShade's movement.

Transporting a Boat Equipped with the Manual SureShade

1. Ensure the shade is in the retracted (closed) position.
2. The canvas should be wrapped with a protective covering and strapped in place so that road debris does not hit and damage the canvas.
3. Cover the extending tubes is needed only if the boat is facing a direction where water and wind could enter the extending tubes of the actuator in the transport direction. The extension of the shade should always face the rear of the vehicle.

The quality marine-grade construction and materials used for the SureShade systems ensure pre-boating season preparation and maintenance is minimal. Proper off-season preparation will help make recommissioning the SureShade in the upcoming boating season will be as simple as possible.

Off-Season Storage

Fully retract the SureShade and protect the unit with a cover or shrink wrap during extended periods of non-use. Cobalt does not recommend removing the canvas from the roller due to the possibility of being reinstalled incorrectly, resulting in subsequent damage to the roller. The roller can stay on the framework as long as it is properly protected with a cover or shrink wrap.

Recommissioning the Manual SunShade System

Inspect the canvas at full extension to ensure there are no deteriorating portions of the canvas, such as rips or broken threads. The actuators for the manual SureShade system are spring-loaded. Controlled extension of the shade is dependent on the canvas, roller and gearbox being well-maintained. Therefore, it is important to ensure the canvas is in good condition to maintain the proper movement of the framework.

Cleaning

SureShade sun shade systems use Sunbrella® fabrics for canvas. Cobalt recommends following Sunbrella's basic canvas care and cleaning instructions to prolong the life of the canvas. (Further information is available at the website: www.sunbrella.com.)

Basic canvas care includes:

- General, light cleaning with a hose on a monthly basis with clear water to remove debris.
- A thorough cleaning every 2-3 years, which may include fabric guard and/or mildew treatment.
- SureShade does not recommend removing the canvas from the roller system as it may be difficult to properly reinstall, or the rollers may be damaged.
- Under no circumstances should the canvas supplied with the SureShade system ever be placed in a washing machine.

See the *Canvas* care information in the *Interior/Exterior Care and Maintenance* section of this owner's manual for additional care and cleaning information. Additional information is also available at www.sureshade.com/customer-resources.



Hardtop with Automated Sureshade—Optional

(Before using this component, be sure to read all the Danger, Warning and Caution statements at the beginning of this section.)

NOTICE

Do not operate equipment that has loose or missing fasteners. Be sure all fasteners are installed and properly tightened before operating equipment.

The SureShade automated tele-frame shade utilizes a patented, telescoping tubular framework to automatically extend or retract the canvas at a touch of a button. The self-supported framework provides shade without the use of inhibiting support poles in the back of the boat that may interfere with boating activities such as fishing, boarding and docking. The fully automated, electric-powered extension and retraction of the shade provides choice, comfort and convenience.

Transporting a Boat Equipped with the Automatic SureShade

1. Ensure the SureShade is in the fully retracted (closed) position.
2. The canvas should be wrapped with a protective covering and strapped in place so that road debris does not hit and damage the canvas. This is especially important for the rollers on the automated system where this is less tension than on the manual system. The wind can balloon the canvas at highway speed in the retracted position and cause damage.
3. Covering the extending tubes is needed only if the boat is facing a direction where water and wind can enter the extending tubes of the actuator in the direction of transport. The extension of the SureShade should always face the rear of the vehicle.

The quality marine-grade construction and materials used for the SureShade systems ensure pre-boating season preparation and maintenance is minimal. Proper off-season preparation will help make recommissioning the SureShade in the upcoming boating season will be as simple as possible.

Off-Season Storage

Fully retract the SureShade and protect the unit with a cover or shrink wrap during extended periods of non-use. Cobalt does not recommend removing the canvas from the roller due to the possibility of being reinstalled incorrectly, resulting in subsequent damage to the roller. The roller can stay on the framework as long as it is properly protected with a cover or shrink wrap.

Recommissioning the Automated SunShade System

Since the SureShade automated system is electrically powered, prior to the first operation each season ensure that the boat batteries are fully powered after off-season storage.

Verify that all power connections are good and that no corrosion has occurred during the off-season.

Inspect the canvas at full extension to ensure there are no deteriorating portions of the canvas, such as rips or broken threads. The actuators for the manual SureShade system are spring-loaded. Controlled extension of the shade is dependent on the canvas, roller and gearbox being well-maintained. Therefore, it is important to ensure the canvas is in good condition to maintain the proper movement of the framework.

Cleaning

SureShade sun shade systems use Sunbrella® fabrics for canvas. Cobalt recommends following Sunbrella’s basic canvas care and cleaning instructions to prolong the life of the canvas. (Further information is available at the website: www.sunbrella.com.)

Basic canvas care includes:

- General, light cleaning with a hose on a monthly basis with clear water to remove debris.
- A thorough cleaning every 2-3 years, which may include fabric guard and/or mildew treatment.
- SureShade does not recommend removing the canvas from the roller system as it may be difficult to properly reinstall, or the rollers may be damaged.
- Under no circumstances should the canvas supplied with the SureShade system ever be placed in a washing machine.

See the Canvas care information in the Interior/Exterior Care and Maintenance section of this owner’s manual for additional care and cleaning information. Additional information is also available at www.sureshade.com/customer-resources.



Bow Shade—Optional

(Before using this component, be sure to read all the Danger, Warning and Caution statements at the beginning of this section.)

NOTICE

Do not operate equipment that has loose or missing fasteners. Be sure all fasteners are installed and properly tightened before operating equipment.

To install the bow shade, flip one the four (4) corner covers and insert the carbon fiber poles into the sockets.

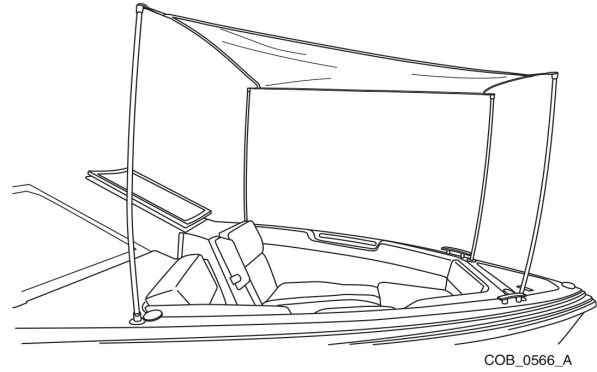

Orient the shade material with the small side toward the bow. Connect the webbing with the “D” ring at each corner to the top of the corresponding pole.

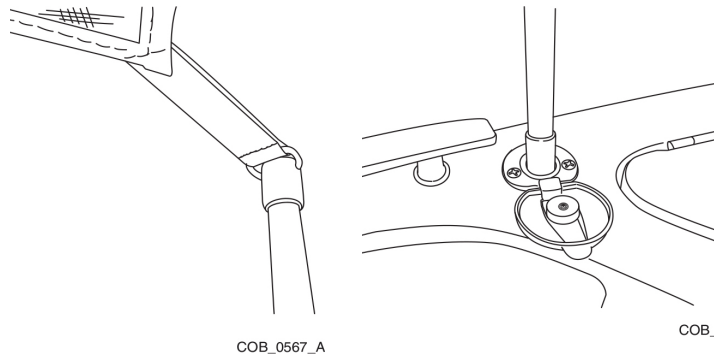

WARNING

DO NOT use the bow shade while underway. Air getting beneath the bow shade while the boat is moving, especially on plane, can upset the balance of the boat and could result in loss of control of the vessel.



Splash & Stow™—Optional

WARNING

DO NOT use the Splash & Stow with the boat underway or while the engine is running. The engine produces carbon monoxide, which is explained in multiple locations throughout this owner’s manual.

The Splash & Stow is located under the aft-facing trunk lid just forward of the swim platform.

To deploy the inflatable Splash & Stow:

1. Access the device by unlocking the latch and lifting the lid.

! WARNING

DO NOT hold onto any part of the device when pressing the button. It is possible for body parts to be caught in the motion and injured. Also keep all loose clothing, hair or anything that might become entangled in the operation.

2. Press down on the arrow located below the lid to deploy the device. You may need to pull on the Splash & Stow to assist it in deploying.
3. After deployment, locate and attach the air hose from the fitting on the device, to the port aft walk-thru deck wall.

NOTICE

DO NOT allow water to enter any fitting or hose.

4. Press the “inflate” button on the panel at the walk-thru area.
5. Press the “air pump on” button and hold for five (5) seconds, then release to turn ON the remote-mounted pump, which is under the starboard cockpit seat. The pump will shut off automatically when the proper pressure is reached. There will be a noticeable change in air pump sound when it automatically changes from low pressure to high pressure model. This is normal.
6. Press the “air pump off” button.
7. Disconnect the hose and install the fitting covers.
8. Stow the hose.
9. Disconnect the inflatable from the roller and attach to the swim platform hoop, if desired.

To stow the inflatable:

1. Disconnect from the platform hoop (if it has been attached) and attach to the roller.
2. Remove the inlet fitting and attach the hose.
3. Press the “deflate” button.
4. Press the “air pump on” button and hold for five (5) seconds, then release. Deflate as much as possible to make it compact enough to fit.
5. Press the “air pump off” button.
6. Disconnect and stow the hose.
7. Install the fitting covers.

! WARNING

DO NOT hold onto any part of the device when pressing the button. It is possible for body parts to be caught in the motion and injured. Also keep all loose clothing, hair or anything that might become entangled in the operation.

8. Carefully align the inflatable and momentarily press the “up arrow” button. The roller will start to turn.
9. Be cautious and do not hold onto the straps, etc., when stowing.
10. Press the button as needed to stow. It may be necessary to align or position the device.
11. Close the trunk lid.

If the unit does not operate, check the breaker located on the battery board under the port aft cockpit seat.

After each use, rinse with clean water and dry the inflatable to prevent stains, mold and mildew. Refer to the manufacturer’s recommendations for more detailed information.





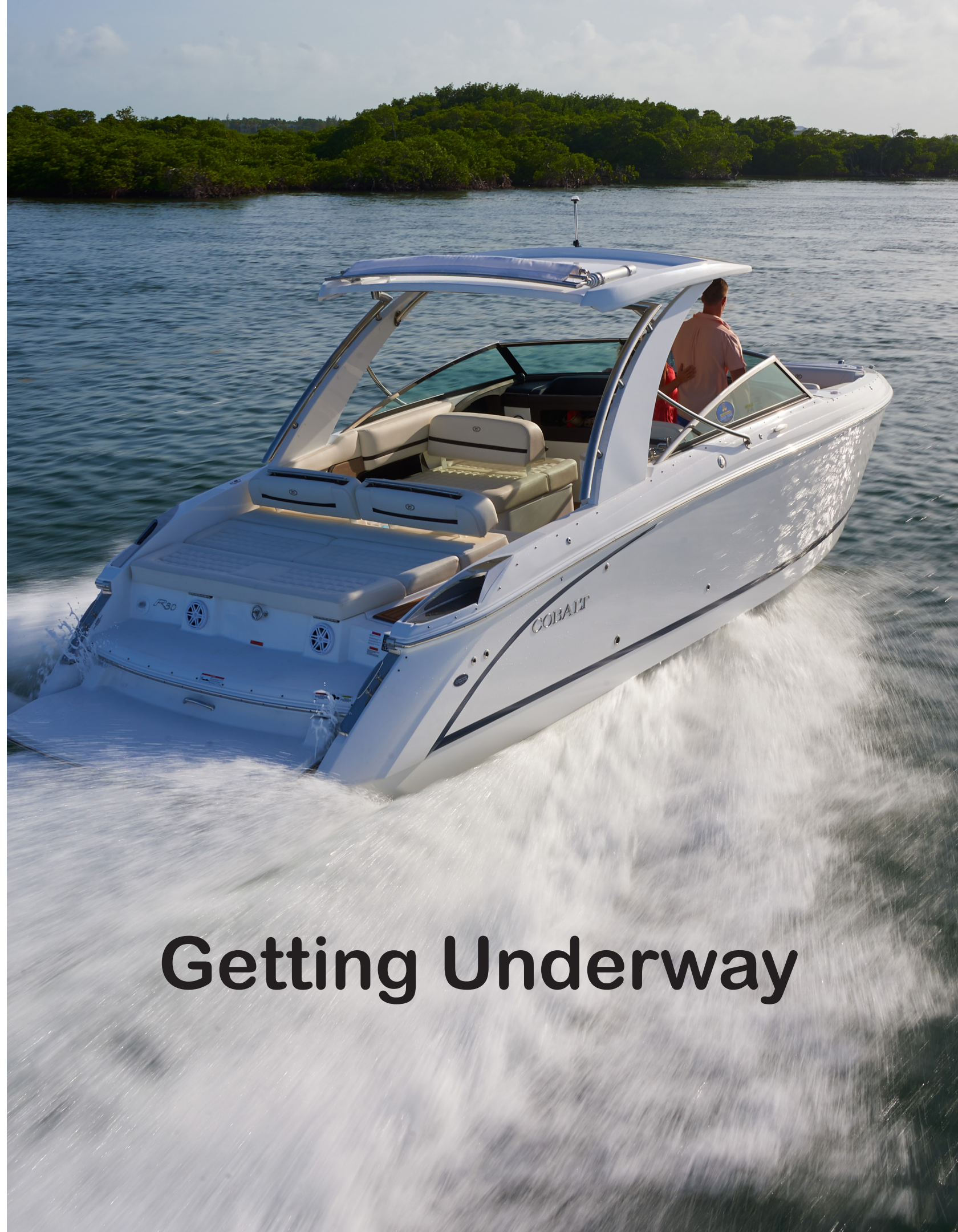

Getting Underway

OPERATING INFORMATION

This section is not intended to provide complete training on all aspects of boat operation. ***Cobalt cannot anticipate and warn of every potential instance that could result in injury or death.*** However, thorough training and education prepares boaters to more quickly and better anticipate and/or react to unusual or potentially dangerous situations.

We strongly recommend that all operators of this Cobalt boat seek additional training on boat handling and safety. Your authorized Cobalt dealer can assist boat owners and operators in the best resources for such training. Have all operators become familiar with the handling characteristics and proper steering and control system usage before attempting operation, and especially prior to high-speed operation.



Improper operation can be extremely hazardous. Read and understand this manual, the propulsion unit operator's manual and any other accessory or components of your boat. Be sure that you understand all controls and operating instructions before attempting to operate the boat.

Your safety, the safety of your passengers, and the safety

of other boaters are among your responsibilities as operator of this boat. Follow the safety recommendations offered within this owner's manual, information on the U.S. Coast Guard's website regarding safety, and always follow common sense in operation and use of the boat. Your boat must be in compliance with USCG safety equipment regulations.

You should know how to react correctly to adverse weather conditions, have good navigation skills and follow the "rules of the road" as defined by the USCG and state, county and local regulations. Refer to the *Safety* section of this owner's manual for more information and details.

We cannot stress enough the importance of reading your propulsion unit operator's manual and following the manufacturer's instructions for breaking in your engine. Other information from component manufacturers may have been included in your new-boat owner's packet, and this information may also be critical to the safety and efficient operation of the boat.

During the break-in period, pay attention to any leaks. There will always be a small residue of water in the bilge, but other water leaks or fluid leaks related to the engine or fuel tank may appear. These leaks can be serious and should be addressed by an authorized Cobalt dealer.

PRECAUTIONS

Before You Start

- Become familiar with the location and operation of all equipment.
- Review the prelaunch requirements as outlined by the trailer manufacturer, and the preparations as required by the engine/drive-train manufacturer.
- Be sure that all onboard fire extinguishing equipment is fully charged and easily accessible.
- Have emergency plans in place.
- Be sure that a float plan or outing information has been left with someone ashore. This means that if any issues arise, there is a person to raise an alarm if you do not return as planned. (Cell phones are helpful, but sometimes service is not available, so bringing a cell phone on an outing should not be the only plan.)
- Ensure all safety requirements as outlined in the *Safety* section of this manual have been met.
- Be certain that the total number of people and gear onboard does not exceed the maximum allowed as indicated on the capacity plate.
- Be sure all gear is properly stowed. Gear that is left loose on the deck can become dislodged, move about during operation and could potentially go overboard or strike an individual onboard, resulting in potential injury. See also *Loading* in this section.
- Check that the steering system is working properly.

- Be certain the battery is full charged and ready for operation.



If it becomes necessary to re-charge a battery from an external source, DO NOT attempt to charge using automotive battery cables or use another boat battery as the source for charging. Some amounts of hydrogen gas are emitted during the charging process. This can be very dangerous. It is critical to keep all sparks, including smoking cigarettes, lighters or any type of flame, well away from a charging battery. Battery chargers for use in marine environments are available.



Inside the battery is an electrolyte fluid that allows the chemical reaction to provide power. The fluid is comprised of several components, one of which is sulfuric acid. As with most acids, this is caustic and corrosive. If it comes in contact with skin, immediately flush the area with copious amounts of fresh, clean water. Follow up with medical assistance.

- Double-check that sufficient fuel is in the fuel tank for the outing or have a plan for refueling.
- Check the weather forecast. Check the predicted wind and water conditions.
- Reconsider any outing that appears threatened by bad weather conditions.



- Check that the drain plugs are fully and correctly installed.
- Ensure that PFDs and other safety gear are onboard.
- Verify the shift level is in the **NEUTRAL** position.



Fire/Explosion

Because fires can occur and spread very quickly, keep PFDs readily accessible at all times. Many fires result in abandoning ship.

Most fires are the result of fuel and oil accumulating in the bilge from careless fueling practices.

When boating in the United States, boats of less than 26 feet in length are required to have at least one B1-rated, hand-held fire extinguisher onboard and fully charged, unless there is an automatic fire extinguishing system installed. If the boat does not have an automatic fire extinguishing system installed, the boat owner MUST purchase and install at least one B1-rated fire extinguisher. Most other countries also have some type of fire extinguishing and suppression requirements for recreational boats.

It is the responsibility of the boat owner and/or operator to determine the requirements for the body of water on which the boating will occur. To avoid citations and/or arrest, boaters should check with local governmental agencies regarding specific requirements and limitations for boating.



Whenever fire extinguishers or suppression units have been used in fighting an onboard fire, a careful determination should be made whether it is safe to operate the boat. In most

instances, it is advisable to have the boat towed to shore rather than risk additional fire or permanent damage to the drivetrain. The boat should be thoroughly serviced by an authorized Cobalt dealer prior to operation again. Operation prior to service could result in additional damage to the boat and may result in serious injury or death.

Even if systems are not discharged, fire extinguishers and suppression units require periodic maintenance. Hand-held units should be examined regularly for rust, corrosion, damage, or leakage. Weigh the unit annually to be certain that it meets the minimum listed on the label. If it has been used at any time, even partially, it should be recharged by a qualified fire-extinguisher servicing company.

When purchasing fire extinguishing and suppression units, Cobalt strongly recommends buying units that are prepared specifically for the marine environment. The standards for these units have been established by the U.S. Coast Guard and the American Boat and Yacht Council (ABYC). In other countries, follow the recommendations and requirements of local jurisdictions and boating authorities.

Cobalt recommends fire extinguishing and suppression systems that exceed the minimum requirements.

In the event of a fire, use the fire extinguisher at the base of the flames, using a sweeping motion. Prudent and accurate use of the available chemicals should contain all but the worst fires.

Verify that the fire has been extinguished. If so, check the damage and get assistance immediately. If the fire cannot be extinguished, get out and swim at least 25 yards (23 meters) upwind from the boat and use the visual distress signals to get assistance.

Refer to the *Safety* section earlier in this owner's manual for additional information.

LAUNCHING

Federal and local laws require certain safety equipment to be onboard at all times. In addition, responsible boaters carry other equipment in case of an emergency. Check with local boating authorities for any additional requirements over and above federal requirements.



Boarding

When boarding the boat, always step in. Do not jump. Avoid stepping on fiberglass or other potentially slippery surfaces. Board one person at a time.

- Do not board the boat while carrying gear. Set the gear on the dock, board the boat and then pick up the gear.



Loading

Do not overload your boat. The performance of your boat is dependent on load weight and distribution. Passengers should distribute themselves to maintain trim. Remember to distribute weight from right to left, and also from front to back.

- Avoid excess weight in the bow or stern.
- Securely stow all extra gear in stowage areas to prevent load shifting. Do not stow gear on top of safety equipment; safety equipment must be quickly accessible.
- In adverse weather, reduce the load in the boat. People/

load capacity ratings are based upon normal boating conditions.

- Do not use the drive unit as a boarding ramp; use the boarding ladder. To prevent injury, make sure the engine is off when swimmers, divers and skiers are boarding. Overloading of passengers, personal equipment and supplies could result in an accident, especially in rough waters. Store all gear in secure areas. Maintain a balanced load at all times.



On the Water

Start your engine before casting off. Remember, the boat turns from the stern. Allow plenty of space between the boat and the dock before trying to move away.



All passengers should be carefully seated while the boat is moving. DO NOT sit on the bow, bow pulpit, deck, gunwale or sundeck pads when the boat is moving.



DO NOT overload the boat. Overloading or uneven loading can cause loss of control, capsizing or swamping, which may lead to death or serious injury. Adhere to the load capacity plate restrictions and always account for persons, gear and all non-factory-installed ballast or other equipment.

GETTING UNDERWAY

There are many things to consider when planning a safe and enjoyable boating trip.

You are responsible for the safety of all passengers, the boat and any damage the boat or its wake may cause. *Keep passengers from blocking your view so that you do not run into other boats, swimmers, water skiers, personal water vehicles or aids to navigation.*



Propulsion System



Always check bilge and engine compartment for fuel fumes before starting the engine. If there is an odor of fuel, do not start the engine until the problem has been fixed and fumes have been eliminated. Always keep hands, feet, hair and clothing away from water intake and drive unit. Do not attempt to clear debris or perform other maintenance while the engine

is running. Always remove the clip from the emergency safety stop switch to prevent accidentally starting the engine while working on the propulsion system.



Do not exceed the posted engine rating of your boat. Boat power capacity has been rated for maximum performance and safety. Exceeding power capacity is illegal in many areas. Never use a propeller that allows the engine to exceed recommended RPM under normal wide-open throttle operation.

Pre-Operation:

- Test operation of the carbon monoxide detectors.
- Open all seacocks and check for leaks.
- Check seawater strainers for leaks and accumulation of debris.
- Open windows, doors and hatches.
- Check that no fuel, oil or water is leaking or has leaked into the bilge compartment.

- Check all hoses and connections for leaks and damage.



DO NOT operate the boat if any problem is found during this inspection. A problem could lead to an accident when using an unsafe boat. Immediately have any issues addressed and corrected by your authorized Cobalt dealer.

- Operate bilge blowers for at least four (4) minutes before starting engines or generators.

During Operation:

- Check gauges frequently for signs of abnormal operation.
- Check that steering, shift and throttle controls continue to operate smoothly.
- Check for excessive vibration.
- Monitor your fuel supply.
- Verify batteries are charged.

After Boating:

- Where equipped, to prevent marine growth from accumulating on the hydraulic cylinder shafts, make sure trim tabs are up and propulsion unit drives are in the full trim **DOWN** position.
- Remove the ignition keys.
- Close all water inlet seacocks.
- If possible, inspect the hull and propellers for damage.
- Clean any spills, stains or moisture from the boat. Inspect sea strainers.

- Remove any food, garbage and wet gear from the boat.
- Secure lockers, hatches and canvas, as equipped.
- Verify that bilge pumps operate properly, and pump the bilges dry by way of the manual switch.
- Clean the bilge and check for fuel, oil and water leaks.
- Stow PFDs and other safety gear and equipment dry.
- Fill fuel tanks (allowing for expansion) to prevent condensation.
- Turn battery select switches off.
- Turn off the DC breaker on the electrical panel. If not using shore power, turn off the AC breaker.
- Notify the person with whom you filed a float plan of your return.
- If the boat is removed from the water, wash the hull and deck exterior with fresh water.



Handling Dock and Mooring Lines

Be sure to use enough fenders to protect your boat from damage. Use only good quality, double-braided nylon line. Protect your boat's finish by using chafing protectors on the lines. Use only the cleats, bow eye and stern eyes to secure your boat. Do not use the handrails or the windshield. The foredeck handrails should be used only for tying a "Jackline" in an emergency situation. If possible, tie up your boat with the bow toward the waves and leave a little slack in the lines to allow for some wave movement or tidal action.



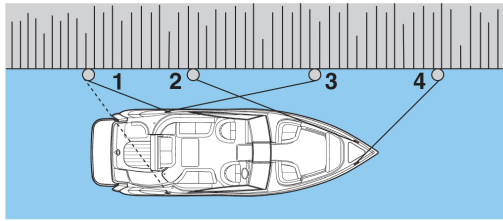

COB_0060_A

- 1 – Stern Line
- 2 – Forward Quarter Spring
- 3 – Aft Bow Spring
- 4 – Bow Line

Use your dock lines to help maneuver the boat near the pier and to secure it. Use the following information to secure your boat to a pile or dock cleat:

The bow line is fastened to the bow cleat and is pulled forward at about a 45° angle. This line keeps the boat from moving astern.

The stern line is fastened to an aft cleat and pulled astern to about a 45° angle. This line keeps the boat from moving forward.

The spring lines can help you control the boat when leaving a dock. Be sure to use spring lines when boating in waters where the tide movement is significant. The forward quarter spring line is fastened to a forward cleat and heads aft. The aft bow spring is fastened to a stern cleat and heads forward.



Never insert a hand, arm or other body part between the dock and the boat or attempt to keep the boat from hitting the dock. The boat could push against the dock, pinning the appendage, and causing severe injury.

Additional docking information is included in this owner's manual.



Care and Maintenance

INTERIOR/EXTERIOR CARE AND MAINTENANCE

The best way to take care of your Cobalt boat is with prevention and proper care. Not all of the care methods within this section may apply to your boat.

ON-GOING CARE

General Cleaning

Cobalt recommends always keeping the boat clean. Immediately after an outing, the boat's exterior and interior should get a thorough rinsing with clear, fresh water, and then should be allowed to air dry prior to covering with canvas. If this is not possible, the boat's cover should be removed as soon as you arrive at your destination and allowed to dry.

NOTICE

Boats must be thoroughly rinsed inside and out with clear, fresh water following all outings and then allowed to completely dry prior to storage or parking. Failure to do so could result in damage to the finishes and the development of mold or mildew, or permanent stains. Such damage is not covered under warranty.

NOTICE

Consumers should never add aftermarket waterproofing to canvas. The canvas must "breathe" to avoid mold and mildew. If any spray-on waterproofing has been added after delivery, it will void the warranty.

If the boat will be left in water, the exposed areas should be wiped down with clear, fresh water and allowed to dry before boat covers are installed.



Salt Water Care and Maintenance

When boating in brackish or salt water, the post-outing cleaning is critical for the protection of the finishes. The cleaning process, internally and externally, is critical to maintaining the warranty in effect and to preserving the engine components. **This is a safety matter.**

The potential for corrosion means that boats operating in this type of condition must be equipped with self-sacrificing zinc anodes. These anodes are attached in several locations. *Check with your authorized Cobalt dealer to be certain that you are aware of all locations of the anodes as they will require periodic replacement.* The anodes serve to significantly reduce the potential for corrosive damage to the permanent metal components on the boat.

NOTICE

Failure to follow ANY of the Saltwater Care and Maintenance instructions for care and maintenance will void the warranty. Significant damage occurs to the engine and boat if proper maintenance is not followed as outlined in the manuals.



Stainless Steel, Chrome and Aluminum Components

While Cobalt uses quality metal components chosen for their durability as well as attractive appearance, all metal eventually reacts to water exposure. Therefore, part of the care and maintenance of metal requires that it is kept clean and dry.

Stainless steel, though highly resistant, is still capable of rusting, particularly in the marine environment. Initial signs of rust and corrosion, left untreated, may result in pitting and permanent damage to components. After an outing, rinse the metal pieces as well as the rest of the boat, allowing a thorough air drying. To avoid spotting and discoloring, drying with a soft rag or towel will keep the new boat look for many seasons to come.

Waxing these metal components helps to preserve the finish. **Do not wax powder-coated surfaces as the wax will collect in the textured surface and be extremely hard to remove.**

Keep your stainless steel looking new by cleaning monthly with a good quality stainless steel cleaner or polish. Always clean and polish in the direction of the grain and finish.

If the boat owner notices rust or deterioration of metal components below the waterline, even when the boat is operated regularly in fresh water, this should be brought to the attention of the authorized Cobalt dealer. In some instances, it is necessary to attach self-sacrificing zinc anodes, even when boating in fresh water.

NOTICE

Damage that occurs to the boat because of corrosion is not covered under warranty.

The following steps will help protect against such occurrences:

Preventive Steps

Clean and wax metal brightwork prior to extended storage. In saltwater or other harsh environments, repeat more often as needed. High-quality stainless steel cleaners and conditioners are commercially available. Rinse with fresh water and wipe dry with a towel or chamois cloth after each use.

Cleaning Stainless Steel

Remove rust or corrosion promptly using a good metal cleaner/polish. Delay may contribute to permanent damage to finishes. Do not use steel wool or other coarse abrasives, or clean with acids or bleach. **DO NOT** use cleaners that are not for use on stainless steel, such as glass, tile or counter cleaners, or citrus-based cleaners. These types of cleaners can damage the surface permanently. Apply metal or auto-

motive wax after cleaning for additional protection. Always test a product in an inconspicuous area before applying to the complete surface.

If hardware or fasteners require replacement, be certain that replacements are rated for the marine environment. See your authorized Cobalt dealer for further information and assistance.



Some solvents are highly flammable and toxic. Exercise proper care in cleaning, wear protective gear and provide adequate ventilation. DO NOT store soiled cleaning cloths onboard; store or dispose of used cleaning cloths properly ashore.



Use caution in cleaning around stitching, wood or other decorative trim, as well as vinyl and flooring, as solvents could permanently damage these materials.

CORROSION PROTECTION

CorrosionX



Regular applications of CorrosionX can protect components that are subject to damage caused by corrosion, a naturally occurring result of operating in marine environments, particularly salt water. A sample can of CorrosionX has been included with the optional salt water kit.

At a minimum, a light coat of CorrosionX should be applied to the following areas and components in the time frames specified (and remove any excess):

Every Month:

- Hydraulic cylinder shafts for steering and other operating mechanisms

Every Two Months (Salt Water):

- Rails
- Stanchions
- Cleats
- Cleat bolts
- All metal fixtures/fittings on deck
- Hinges/locks/closure mechanisms on doors and windows
- Sliding tracks on doors and windows

Every Two-to-Three Months:

- Light sockets

Every Three Months:

- Bilge pump housing and connections
- Other metal within the bilge area
- Thru-hull fittings
- Seacock fittings

Every Four Months (Brackish and Fresh Water):

- Rails
- Stanchions
- Cleats
- Cleat bolts
- All metal fixtures/fittings on deck
- Hinges/locks/closure mechanisms on doors and windows
- Sliding tracks on doors and windows

Every Six Months:

- Plumbing connections in the galley and head areas
- Entire engine, including engine mounts, unless otherwise directed by the engine manufacturer
- Fuel line fittings at the fuel tank

Once a Year (All Water Environment):

- Electrical connections
- Fuse panels
- Antenna bases
- Hinges/locks/sliding tracks of doors and windows

A good rule of thumb: If a component can rust or corrode, whether it has or not, it requires application.

For any questions about CorrosionX, check the manufacturer's website:

<http://www.corrosionx.com>

or call 800-638-7361.

Avoid getting CorrosionX on other, non-metal surfaces, particularly vinyl seats or flooring. If this occurs, clean immediately as directed by the product's directions to avoid stains that are also not covered under warranty.

NOTICE

Failure to use CorrosionX as directed on the product label will result in the nullification of the Cobalt warranty in instances of corrosion damage. Failure to clean CorrosionX off non-metal surfaces can result in damage that is not covered under warranty.

NOTICE

Cobalt uses only marine-rated and marine-grade fasteners on all models. If, at any time, it is necessary to replace any fasteners, seek guidance from an authorized Cobalt dealer to ensure that such replacements meet the requirements for operation in a marine environment.



Galvanic Corrosion and Zinc Anodes

Galvanic corrosion can result in serious damage to any metal component of your Cobalt boat. Galvanic corrosion is the deterioration of metals due to the effects of electrolytic action. When dissimilar metals are immersed in a conductive

fluid such as salt water, an electric current is produced, similar to the action inside a battery.

Galvanic corrosion can occur in fresh water or salt water; however, salt, brackish and polluted waters accelerate galvanic corrosion.

When a self-sacrificing anode is installed on your Cobalt boat, it works to help prevent damage to metal components from galvanic corrosion. The anode is attached to the exterior of the boat, on the transom below the waterline. Other metal components are attached to the transom zinc anode via grounding wire. *(There may be additional anodes affixed; check with your Cobalt dealer for details.)*

The anode will require frequent inspections. If the anode shows deterioration of 50% or more, it must be replaced for continued protection. Please note that because this is a natural function of operating in certain bodies of water, the cost of replacement is not covered under warranty.

NOTICE

The sacrificial zinc anodes do not totally eliminate the corrosion process from the rest of the boat and its components. It is critical for the boat to be rinsed and flushed after EACH use. Failure to do so will void the warranty.

NOTICE

DO NOT paint an anode, its fasteners or its mounting surface. Painting will reduce the anode's corrosion protection capabilities. Make sure the anode's contact to its mounting surface is clean and secure.

Refer to the propulsion unit operator's manual and speak with your Cobalt dealer for requirements or galvanic corrosion protection for the unit.

VINYL INTERIOR AND UPHOLSTERY

(The following overview contains information that is applicable to canvas and other material used in production for comfort and protective elements of the boat.)

NOTICE

The performance results shown in this information are not guaranteed for all upholstery products. The evaluations are indicators after laboratory tests and may not be indicative of field performance.



Mold & Mildew Cause and Prevention

Mold and mildew spores are ever present in air and soil, and most will germinate when exposed to temperatures above 75°F and relative humidity of 50%, with rapid spread

occurring at 80%; however, some can grow in significantly lower temperatures and RH levels.

All fabrics will support growth but some synthetics are treated with an anti-microbial agent which adds to their growth resistance. Anti-microbial treatments protect the base surface itself, so that alone won't support spore growth. However, organic soiling on top of those surfaces will. Once a population is established on the cover, vinyl seating or gel coat, an irregular stain will appear which ranges in color from gray to black; however, yellow, orange, and red stains are possible. Sometimes UV exposure can fade them but most often they remain permanent stains.





Treatment

(This is very time-consuming, with limited expectations of success. Therefore, it is desirable to avoid the necessity of mold and mildew treatment.)

- If growth is established, vacuuming with a HEPA filter unit would be the first step followed by cleaning.
- For fabric and vinyl surfaces, shampoo lightly with an upholstery shampoo.



Focus on Prevention

The key in eliminating mold growth is controlling moisture. Remove it as a factor and growth simply will not occur, so maintaining a cool and dry condition with clean surfaces is paramount. Using a dehumidifier isn't practical for boat storage, but a simple remedy can be using desiccant bags. They must be monitored as they will absorb moisture and become ineffective, but they can be replaced, and this is a relatively inexpensive method. They are available in packs for a normal-sized boat and called Boat Dry, purchasable from Sun Solutions at ww.sunsolutionproducts.com.

When the boat is ready to store, the best practices are:

- Clean and dry the boat thoroughly.
- Place a Boat Dry set of desiccant bags throughout the boat.
- Put the mooring cover on and tightly ratchet (seal will be created at the rub rail).

Drying out a boat is difficult but the extra care you take will keep your boat looking new for a long time.



Condensation Cause and Protection

Water vapor in the atmosphere will condense onto another surface only when that surface is cooler than the dew point temperature, or when the water vapor equilibrium in the air has been exceeded. The dew point temperature is based on the air temperature and relative humidity. A typical example is with 90°F air temperature and 50% RH, the dew point temperature is about 73°F.

Many times during the evening, dew will condense onto all outdoor surfaces like grass, cars, patio furniture, toys, bikes, and the like as the air temperature and surfaces cool below the “dew point.” Once the morning sun heats the air temperature or those surfaces heat up enough, the dew will evaporate back into “humidity” and this cycle continues as long as the weather conditions permit.

When you cover your boat, you are sealing the outside air in its present state under the cover. Also, if the boat wasn't dried out, that additional moisture will add to the wetness of the trapped environment. As the air and surface temperatures cool below the dew point the water vapor in that air will condense onto all surfaces inside the boat. In the morning, it will take longer to heat the air and surfaces under the cover as it affords protection, thereby lengthening the time it takes to have the condensation evaporate. It's very possible if weather conditions change that the condensation may not return to vapor for quite some time.

This condition is often misunderstood as the cover “leaking” water through the fabric, but because of the fabric's high hydrostatic water resistance (160 cm) this is not possible. It's understandable to think that having the cover wet underneath is somehow due to it allowing water through, but it is just condensation forming on its surface.

It's like camping in a synthetic tent; if you've ever done it, you'll remember water beads form on the tent surface, and bumping the tent would cause them to "rain" on you.



Pooling Water

Water can pool inside the deck or on a canvas cover for various reasons. If pooling is noticed, the standing water should be drained or otherwise removed as soon as possible. Pooling water accelerates the process of mold/mildew development, as well as other serious staining and potentially permanent damage.



Current Reality

To have a mildew problem, four elements are required. For mildew to proliferate, spores, food, warmth, and moisture are necessary. Elimination of one of these elements would break the cycle, and the mildew problem would be eliminated.

The most likely element to control is moisture. Keep surfaces dry and the ambient air dry, and you can break the link. This is very difficult. Marine upholstery may be dry when one sits on it, but it is constantly exposed to rain, splashes, and wet bathing suits.

Dirt carried by the wind or a sudden shower will carry the spores or seeds to begin the process, inoculating the surface. Surface debris can easily be washed off, but what happens to the contamination that gets into a seam or stitch holes?

A closer examination reveals that a marine seat is a very complex construction. The vinyl that you look at or sit on is only a part of the total construction. The vinyl is usually attached to a fabric to give it dimensional stability and physical strength. Urethane foam of various thicknesses provides a cushion, and the whole seat is usually built on a piece of plastic.

If contaminated dirt carried by rainwater gets inside the cushion, the biological growth cycle can begin. It is quite common for soil organisms growing in the foam cushion to produce colored by-products, the most notable of which is a pink compound.

This dye is soluble in plasticizer (an ingredient in flexible PVC) and will diffuse and migrate to the vinyl surface. Even though the vinyl compound is adequately protected against mildew growth, pink staining can occur if contact is made with components of a seat which support mildew growth. This stain cannot be removed by washing.



The Solutions

As in most complex problems, there are a variety of actions one can take to prevent microbial problems. These actions must be directed to the components of the product and the total construction. Working together, they will assure the highest probability of success in eliminating quality problems associated with mildew contamination. The solution consists of four components:

- Keep seats clean.
- Remove or kill any surface growth.
- Use materials that are treated to inhibit fungal growth.
- Keep surfaces covered, if possible, when not in use.

NOTICE

The vinyl used in Cobalt boats contains the biocidal product n-octyl isothiazolinone (OIT), an antifungal additive used to help maintain appearance, physical properties and prolong the service life of the vinyl.



Additional Information

The vinyl and interior fabric in your Cobalt boat has been specially selected to hold up under the elements and usage of an active boater. Even quality material is vulnerable to abuse, however. Cobalt upholstery requires reasonable care and treatment, and to that end users should also avoid sharp objects that may cut or tear your vinyl.



Care and Cleaning of Vinyl

Most common everyday light soiling can be easily removed by using a solution of 10% liquid household dish soap and 90% warm water, applied with a clean, dampened cloth. Rinse with a clean cloth dampened with water and allow to dry. Moderate scrubbing with a soft-bristle brush will help loosen dirt and grime embedded in the grain of the vinyl.

See specific cleaning instructions provided by the manufacturer and located in your boat packet.

NOTICE

It is extremely important to clean the stained area as quickly as possible, making sure the recommended cleaning steps are followed in order.



Avoid open flame or spark. Some cleaning fluids contain flammable liquids, which are extremely dangerous and must be used in well-ventilated areas.





Vinyl Sauce

Between thorough general cleanings of the vinyl, a product called Vinyl Sauce is approved for cleaning, particularly spotting. To use it:

- Spray Vinyl Sauce directly on the vinyl and wipe away any residue with a clean cloth that has been dampened with water.
- For spot treating spills or heavily soiled areas, spray Vinyl Sauce on the seat. Allow it to stand for a few minutes and then scrub with a soft-bristle brush to help loosen dirt and grime embedded in the grain of the vinyl. Wipe away any residue with a clean cloth that has been dampened with water.
- Repeat as necessary to remove remaining spots.



Care and Cleaning of Fresco Chill™ Chil Cool Technology™ Vinyl

Use non-bleach mild soap and water **ONLY** to clean Chil Cool Technology™ vinyl upholstery. Boat Bling Mild

Soap Sauce has been approved for use on Chil™ vinyl. Failure to care for the vinyl properly or use of improper cleaners may void the warranty and damage the vinyl.

- Spray Mild Soap Sauce directly on the seats and wipe away any residue with a clean cloth that has been dampened with water.
- For spot treating spills or heavily soiled areas, spray Mild Soap Sauce on the seat, allow it to stand for a few minutes and then scrub with a soft-bristle brush to help loosen dirt and grime embedded in the grain of the vinyl. Wipe away residue with a clean cloth that has been dampened with water. Repeat as necessary to remove remaining spots.

NOTICE

It is extremely important to clean the stained area as quickly as possible, making sure the recommended cleaning steps are followed in order.



Dark Stowage Area

When a boat is stored completely covered or in a dark building, the vinyl may darken or become “dingy” in appearance. If this happens, simply place the boat in direct sunlight for a few hours. The vinyl should brighten up.



Spot and Stain Removal

Even with routine maintenance, stains and spots will occur. Clean up spills as quickly as possible. Watery spills should be blotted with clean cloths or paper towels. Thick jelly-like substances should be removed with a spoon or blunt scraper, and then blotted. Solids should be scraped using a blunt scraper and then swept, brushed or vacuumed to remove the material. After removal of the majority of the

spilled material, it is important to complete the removal process so the spill does not have a chance to affect the flooring.

Whittaker manufactures a spotting and brushing system using Crystal Dry Spotter and Cleaning Agent and the Whitaker Carpet Roamer™; it is effective in cleaning the stains listed below where brushing is required.

Plynyl is stain-resistant, not stainproof. To avoid lasting stains, blot and clean stains immediately. The following list shows stain-removal procedures for some common spills and other tough-to-clean areas.

NOTICE

The material and vinyl used in Cobalt interiors has been treated to be stain-resistant. It is not stainproof. Remove staining agents as soon as possible to improve the odds of avoiding permanent stains.

Removal Suggestions

<u>Stain</u>	<u>Removal Procedure</u>
Shoe heel marks	Use medium-bristled scrub brush and follow with mild detergent solution.
Blood, chocolate, catsup, white glue, egg, ice cream, butter	Spray on a mild detergent solution and allow it to dwell for 1 minute. Brush with a medium-bristled scrub brush, and then blot with paper towels. Repeat until discoloration is removed.
Berries, fruit juices, cream, soft drinks, milk, wine, beer, coffee, tea	Spray on a mild detergent solution and allow to dwell for 1 minute. Blot with white paper towels. Repeat until discoloration is removed.
Excrement, vomit, urine	Spray on a mild detergent solution and allow it to dwell for 1 minute. Brush with a medium-bristled scrub brush, and then blot with white paper towels. Repeat until discoloration is removed.
Shoe polish, asphalt, grease, oil, ink, lipstick, crayon, wax, paint, rubber cement, seam sealer	Remove as much residue as possible using white towels, paying attention to keeping the stain from spreading. Use a mild solvent (Bane Clene Saf-T-Solv®) placed on white towels and then applied to the stained area. Repeat the application of the solvent and gently agitate the area as much as needed. Overapplication of any solvent can dramatically affect the integrity of Plynyl. Follow solvent cleaning with a detergent rinse.
Mercurochrome, Merthiolate, Betadine, tomato sauce, spaghetti sauce	Spray on a mild detergent solution and allow it to dwell 1 minute. Blot with white paper towels. If discoloration is not removed, dilute household bleach to 1:10 bleach-to-water, mist on affected area and allow it to dwell for 5 minutes. Rinse thoroughly with water to remove all bleach residue.
Chewing gum	Freeze with compressed air and break away from material surface. Follow with mild detergent and a medium-bristled brush.
Rust	Treat with a reducing agent and follow with a mild detergent rinse (may require professional assistance).

Follow all cleaning procedures using common detergents with a water-only rinse in order to removal all residual cleaning agents (if Crystal Dry is used, a follow-up water rinse is not required). Allow the area to completely dry before allowing traffic in the area. **NOTICE: Stains that cannot be removed under the listed procedures can be treated with a 1:10 bleach-to-water solution. Mist the solution on the area of discoloration and allow it to dwell for five (5) minutes. Rinse the area with water only in order to remove the bleach residue. Allow to dry completely before trafficking. Some stains may require a professional to complete the stain-removal process.**



Leather Care

For spots and spills, wipe up excess liquid immediately with a clean absorbent cloth or sponge. If necessary, use clean lukewarm water only and let air dry naturally. If water is used, clean the entire area where the spot occurred. For example, clean the entire seat cushion or entire arm.

Do not dry wet areas with hair dryers.

For stubborn spots and stains, use a mild non-detergent cleaner such as a bar of Ivory Soap™ or Amway™ L.O.C. Apply the soap to a clean, wet sponge, wash, and then rinse well. Allow to air dry naturally.

For butter, oil or grease, wipe any excess off the leather with a clean dry cloth, then leave it alone; the spot should dissipate into the leather in a short period of time. Do not apply water or try to wash butter, oil or grease spot.

NOTICE

DO NOT use saddle soap, cleaning solvents, furniture polish, oils, varnish, abrasive cleaners, soaps or ammonia water.



Canvas



Under no circumstance are these fabrics to be put in hot water, run through the hot drying cycle of an automatic dryer or steam pressed at a dry cleaner. Fabric should be air-dried.

The optional bow and/or cockpit tonneau covers, Bimini top or Bimini enclosure on your Cobalt boat are manufactured from top-quality materials to provide you with years of trouble-free service when properly maintained.

The following information is provided to help maintain the appearance and ease of operation.

Cobalt uses Sunbrella®, a woven fabric made of 100% solution-dyed acrylic fiber. It is very colorfast and will withstand long-term exposure to the sun (ultra-violet) without

excessive fading or deterioration.

- Do not store canvas wet or in an unventilated, moist area.
- Always roll the canvas instead of folding.
- Roll the top carefully around the bows and cover with the storage boot provided.
- Your canvas is designed and intended for short-term use only. Do not use it for storage.
- Do not tow your boat with the top in the upright position.

Cleaning Canvas

Canvas should be cleaned regularly before substances such as dirt particles are allowed to accumulate on and become embedded in the fabric. The fabric can be cleaned without being removed from the installation. Simply brush off any debris, hose down and clean with a mild solution of natural soap in lukewarm water (no more than 100°F). Rinse thoroughly to remove soap. **DO NOT USE DETERGENTS.** Allow to air dry. Do not store canvas wet or in an unventilated, moist area as it will result in mold or mildew penetration, which is difficult to remove.

Special Cleaning Problems

For heavily soiled fabric, remove the top from the frame. Soak the fabric for approximately 20 minutes in a solution that has been mixed to the following proportions:

- ½ cup (4 ounces) of non-chlorine bleach
- ¼ cup of mild soap like Ivory Snow, Dreft™, or Woolite™
- One gallon of lukewarm water (water should be no more than 100°F (37.8°C))

Allow the fabric to soak until the non-chlorine bleach has killed the mildew or other microbes and the stains can be brushed out with a soft scrub brush. Rinse the fabric thoroughly in cold water to remove all of the solution.

This may require rinsing several times. **Incomplete rinsing can also cause deterioration of sewing threads and prohibit the fabric from being properly retreated.** Do not soak excessively, since the non-chlorine bleach can deteriorate the sewing threads. Allow the fabric to air dry completely.

Sunbrella may also be dry cleaned. **DO NOT STEAM PRESS OR DRY IN AN ELECTRIC OR GAS DRYER.** Sunbrella is thermoplastic, or heat sensitive. Excessive heat can damage and shrink the fabric.

These methods of cleaning may remove part of the water and stain repellency that was applied to the fabric during its manufacture. The fabric should receive an application of an air-curing treatment such as “303 HIGH TECH FABRIC GUARD” after it has been cleaned.

NOTICE

Failure to follow canvas care and maintenance instructions as explained in this section of the owner’s manual can result in deterioration of the product, which is not covered under warranty.



Other Canvas Components

Clear Vinyl “Isinglass”

The clear vinyl “isinglass” used in side curtains, aft curtains and visors is very reactive to heat and cold. Carefully unroll the vinyl in cold weather to avoid cracking. Keep vinyl side curtains from touching the bows (tubing) to prevent burning the vinyl. If the boat is stored with top, side curtains and aft curtain in place, heat buildup inside of the boat may discolor the vinyl.

Use a soft, clean cloth with a solution of Ivory or Lux soap, liquid or flakes, and lukewarm water. Never use any harsh or abrasive cleanser; these types of cleaners will scratch the glass. To keep the vinyl soft and flexible, regularly apply a UV screening agent such as “303 PROTECTANT.”

- Do not fold or wrinkle curtains; roll smoothly when storing.
- **NEVER** store the isinglass wet or in an unventilated, moist area.
- Always roll the glass instead of folding.
- Handle the isinglass carefully. It is soft and very prone to scratching.

Zippers

When zippers are new, they can be more difficult to zip than when “used.” Zip carefully without forcing. They will loosen with use. Keep the zippers clean. A zipper lubricant may be used to help new zippers and to maintain long service. The most vulnerable part of the zipper is the base. Use care when starting a zipper to prevent damage.

Snap Fasteners

Fasteners should be unsnapped as close to the button as possible. Never remove canvas by pulling roughly on one edge of the material. This can damage the canvas and the fasteners. To prevent snaps from becoming difficult to unsnap, keep them clean and use lubricants such as a small amount of Vaseline®, Chapstick®, WD-40®, silicone spray, etc. The most common recommendation is to rub candle wax or paraffin around the stud or inside the socket.

Whichever method is used, clean up any excess application so the lubricant does not stain the canvas or any other surfaces it may contact.



Inflatable Accessory Care

Care and maintenance are essential to ensure the life of the product. Also remove an inflatable from the water and keep out of direct sunlight when not in use. Although normal wear and tear is unavoidable, proper cleaning will improve longevity.

Clean the inflatable rinsing all hardware, co-rings, d-rings, etc., with fresh water after every use. Clean the inflatables by using a mild soap with fresh water and soft tow-



els. **Never use silicone-based products.** For longer periods of non-use or storage, Cobalt recommends the inflatable be thoroughly cleaned and **dried** to avoid mold or mildew.



Storage Compartments

NOTICE

Storage compartments, including the glove box, should be kept clean. Failure to do so may result in damage or permanent discoloring and/or odors that are also not covered under warranty.

Storage compartments, including the glovebox, should be cleaned out in accordance with the *Care and Maintenance* instructions in this owner’s manual. At least annually, all compartments require a thorough cleaning. If anything with residual odor is placed in a storage compartment, or if anything has spilled in the compartment, cleaning should occur as quickly as possible afterwards.

Do not store any aerosol items in the glove box. These can overheat and leak, and/or rupture. Any liquid or semi-liquid material placed in the glove box may spill or



overheat. Care should always be used when placing liquids such as suntan lotion in the glove box. Cobalt is not responsible for such misjudgments.

If any water intrudes into a storage compartment or the glove box, clean it out as soon as practical. Mold and mildew can result if even small amounts of water are not removed. As with any storage location, any spills should be cleaned efficiently to avoid damage and/or odors.



Cabinetry and Wood

Cabinetry

Clean with any water-rinseable non-abrasive cleaner.

Wood Grain Dash

Your Cobalt boat may be equipped with a wood grain dash, which will maintain its natural beauty and high-gloss sheen when properly maintained.

- For routine cleaning, wipe the surface with a damp, soft cotton cloth. For thorough cleaning, wash the surface with a mild solution of soap and water, and dry with a soft cotton cloth.
- Do not use cleaners or polishes containing alcohol, ammonia, abrasives, oily emollients or petroleum-based materials.
- Avoid saturating the surface with polish or wax. In some instances, foam-backed tape used in manufacturing will absorb and retain these substances and result in premature fading and/or discoloration of your wood grain dash. If cleaners or waxes come in contact with edges, clean the surface immediately with a mild solution of soap and water.

Teak

Cobalt boats may be equipped with teak, including trim. To keep teak in top condition, clean it occasionally with a teak cleaner and re-oil it at least once during a season. Follow the manufacturer's instructions and warnings carefully. Some cleaners are oils may damage gel coat, vinyl, stainless steel or aluminum finishes. Avoid using rust-producing steel wool pads when cleaning. Materials can be purchased from an authorized Cobalt dealer.

NOTICE

Teak sealers and cleaners can be harmful to other materials. Be sure to thoroughly remove any sills or excess. Teak should never be varnished. The natural oils in teak will cause poor adhesion. Damage as a result of failure to follow instructions is not covered under warranty.

DANGER

Never store rags or cleaning cloths used to treat teak. Store or dispose of cleaning materials on-shore.



Cedar

Wipe the surface with a dry cloth or a slightly damp cloth. Do not seal or paint cedar.



Carpet

Vacuum the carpet on a regular basis. Use household carpet stain removers and cleaners to clean the carpet.



Sea Grass Floor Covering

General Maintenance Instructions

Plynyl® is made with a woven vinyl fabric bonded to commercial-grade backings. Vinyl is a very tough, durable material and few household or common office chemicals affect it. Routine maintenance along with periodic cleanings and diligent attention to stain-causing spills will provide a long, useful life.

The frequency of routine maintenance depends on the application. The frequency has to be determined by the user or through consultation with the manufacturer. The methods for routine maintenance as well as cleaning methods also depend on the application. Frequency depends on the amount of soil and dirt Plynyl is exposed to. Dirt and soil will degrade any flooring, so proper maintenance will increase its natural life cycle.

Plynyl is unique among soft floor coverings because water can be used effectively in daily maintenance. Detergents and shampoos with a pH up to 11 can be used repeatedly and safely. However, it is recommended to use the lowest pH detergent that provides a satisfactory result. When using water with any of the maintenance techniques listed, be sure not to leave any standing water and keep foot traffic off the floor until it is completely dry. Also, do not over-wet

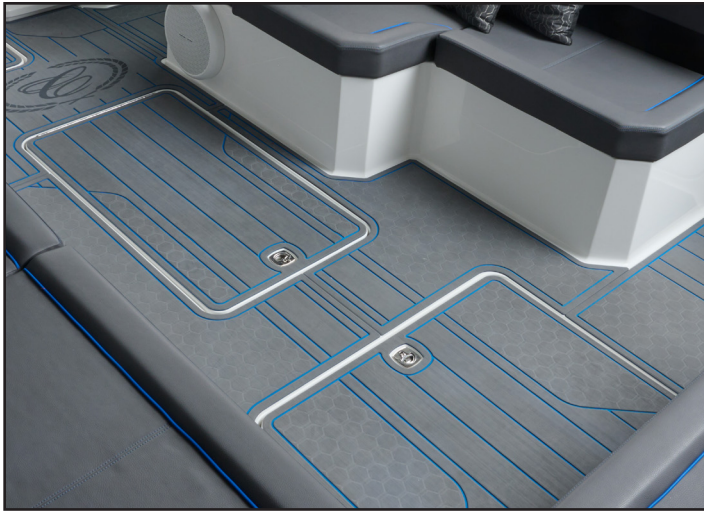

areas to be cleaned.

Do not use acetone, Pine-Sol® or citrus-based cleaners, as they can damage Plynyl. Solvents containing xylene or toluene may be used in a limited fashion as a spotting agent. See *Spot and Stain Removal*.

Plynyl w2w and tile are not absorbent and therefore are not recommended to be used in street-level entrances as walk-off mats.

A walk-off mat should be provided in every installation to reduce the tracking of soil and other foot-borne contaminants onto the Phymyl floor. If a walk-off mat is not provided, it will result in premature wear of the Plynyl installation.

Sealers, waxes, stain repellents and other topical applications are not required for Plynyl. Using a powder cleaner such as HOST is not required; it does not result in more-effective cleaning.

Direct contact between natural rubber and Plynyl will cause discoloration in Plynyl. Avoid the use of rubber castors, furniture pads, or other rubber pad or cushion products.

It is necessary to use chair pads under rolling chairs to protect Plynyl fabric and seams.

Maintenance Techniques

The most common and easily accessible maintenance options are the vacuum cleaner and mop. Either is effective in picking up and removing dirt. If a vacuum cleaner is used, the beater brushes should be lowered so it brushes the surface of the Plynyl to release dirt and brush out scuffs.

In the absence of additional cleaning methods as noted below in the Periodic Comprehensive Cleaning, mopping is slightly more effective than a vacuum cleaner because it can be used with a detergent. If a detergent is used in mopping, spread it out on the area to be mopped, allow it to stand for thirty (30) seconds to one (1) minute, and then mop the area.

Rinse the mop with clean water and apply detergent again, if necessary. Rinse and mop with at least one additional clean-water rinse after applying detergent, as deter-

gent residue will attract soil if it is not rinsed properly.

For modest-sized installations, Hoover manufacturers a floor-cleaning machine called the Hoover FloorMATE™, which was designed especially for flat-surfaced floors such as wood and tile. It works very well with Plynyl as well. It uses water, detergent and rotary scrub brushes to aggressively remove soil and dirt. Follow the manufacturer's instructions for use. It can be found at Hoover's website. The FloorMATE can also be used with Crystal Dry™.

Periodic Comprehensive Cleaning

There are several methods that work well.

The whittaker GLS™ Carpet Cleaning System with Crystal Dry™ works very well in combination with routine vacuuming. This system relies on Crystal Dry, a detergent that suspends oil into dry crystals that can be vacuumed easily. Crystal Dry's advantage over conventional detergents is that it does not leave a soapy residue that may attract more dirt. Periodic cleaning with Crystal Dry would be done using the GLS, Whittaker's carpet cleaning machine. The GLS has twin cylindrical counter-rotating brushes that are effective removing soil from Plynyl without abrading the fabric. Whittaker products are available at www.rewhittaker.com, or by calling 800-422-7586. (GLS, Crystal Dry and Carpet Roamer are trademarks of the R.E. Whittaker Co.)

- Crystal Dry by Whittaker can also be used with a rotary bonnet and pad. It is recommended to saturate a cotton microfiber pad with Crystal Dry to clean the floor. Care should be taken to ensure the pad stays moist. It is not necessary to rinse Plynyl after treating with Crystal Dry.
- Plynyl can be cleaned with a rotary bonnet and pad in combination with conventional detergents. The pad should be a green-striped cotton pad available from most industrial suppliers such as Grainer. First, a detergent should be applied to the surface and allowed to stand for thirty (30) seconds to one (1) minute. Pass over the floor three (3) to four (4) times with the rotary bonnet and pad. To pick up the detergent, pass over the floor again with the rotary bonnet, but with a clean, dry cotton pad. Care should be taken to remove all the detergent residue or it may attract more dirt. Care should also be taken not to abrade the Plynyl with the rotating pad. Hard-to-remove stains should be treated by hand, not machine, per the instructions in *Spot and Stain Removal*.
- For large installations, cleaning can be accomplished with an auto-scrubber. When using an auto-scrubber, activate the scrubber brushes and vacuum bar, then set the automatic solution dispenser on medium to high. Follow the manufacturer's recommendations to get the best results from the equipment. Do not exceed an 11pH for chemicals used in the machinery. As noted earlier, care should be taken to remove all detergent resi-



due or it may attract more dirt.

- Interior Preservation Inc. (IPI) is an approved maintenance provider. They have a nationwide network of service providers. Call Tony Doria at 800-820-0008, extension 109, for a local provider.



Deck and Hull Finishes

Much of the finish surface of the hull and deck is a fiberglass-reinforced resin. While the boat material is sturdy, to ensure an enjoyable experience while boating, the fiberglass and resin layers, and gel coat finish (where the paint is embedded), is very thin—only a few millimeters in depth. To keep it looking like new, it is important to keep it clean and waxed. The finishes used by Cobalt are the finest available on the market today. However, the finish is not impervious to the elements and many types of water conditions, and attention must be given to care and maintenance on a regular basis.



Cleaning the Deck and Hull

The finish on a Cobalt boat is known as gel coat. The gel coat used is the finest available on the market today. With all its properties, however, it is not impervious to the elements and many types of water conditions. To clean the deck and hull, a multi-purpose boat soap (3M carries a complete line of fiberglass care products) should be used to clean the exterior fiberglass/gel coat surfaces on the boat **after each use**. This product, depending on the ratio mixed, is designed to clean anything from dirty hulls and decks

to greasy engines. Always rinse and wipe well with a damp towel or chamois.

A fiberglass restorer/wax should be used to remove heavy oxidation, characterized by a chalk-faded surface as well as rust and exhaust stains. This product will not only remove the oxidation but also leave a wax protection on the cleaned surface in one application.

Paste wax will help retard UV light damage. Three (3) coats are suggested for application at the end or beginning of your boating season, depending on the type of off-season boat storage used (covered, enclosed storage facility, etc.), and again mid-season.

Detail spray such as Boat Bling Hot Sauce may be used between wax applications to prevent hard water spots from accumulating on the fiberglass gel coat and painted surfaces.

Step 1: Spray Hot Sauce directly on a 2-to-3-foot section of the interior or exterior fiberglass. Wipe away residue to a streak-free shine.

Step 2: Wipe away overspray from the vinyl upholstery and rubber rails.

To extend the life of the gel coat finish, use a Cobalt marine mooring cover that totally covers the top deck of the boat. Additionally, if the boat is going to be stored where the sun is constantly on the side or transom of the boat, consider having some custom skirting made to complement the mooring cover and prevent sun fade or bleaching.

Tonneau covers will supply adequate short-term protection to the interior, but will not protect the gel coat finish.

Check with an authorized Cobalt dealer for more assistance in this critical care and maintenance.



Additional Cleaning Advice

When using specified products as directed on the cleaning container, all the surfaces of the boat (in addition to the vinyl and flooring care described above) should be cleaned and protected between each use. Be certain to also clean the engine as directed by the engine manufacturer. Always rinse and wipe off the finish with a damp towel or chamois cloth.

If you choose to wash the boat at a car wash, do so with care. Stay back from the boat surface to avoid potential damage from the high-pressure sprayer, and do not use the “soap” setting as most car-wash soaps are intended to deal with highway-type debris such as salt, road tar, and similar environmental hazards. Wash the boat by hand with mild soap as noted above, and then rinse carefully.

NOTICE

Harsh detergents and cleaners will quickly damage the finish, and this is not covered under warranty.



Soft Track Mat and Swim Platform Mat Care and Maintenance

General Cleaning

Regular cleaning can be accomplished by washing the mats with mild soap and water and using a medium-to-stiff bristled brush. Although the swim platform mat is stain-resistant, some things that would be expected to stain almost anything may stain the mats if left in contact with the mats for an extended period of time. It is always best to clean or rinse away any spills as soon as possible. Work the cleaner into the stain with a medium-to-stiff bristle brush, brushing with the grain texture, and rinse with a hose to finish.

Suggested cleaners:

- Simple Green®
 - Soft Scrub®
 - Fantastik®
 - Formula 409®
- (Bleach may be used, but avoid any acid-based cleaners like FSR.)

Things to avoid:

- Sharp objects such as knives or tools dragged across the surface.
- Pressure washing due to the risk of shredding or cutting the mats.
- Extended contact with petroleum-based products. This can cause a stain that may not be removed.

Storage

The swim platform mat is very resistant to most weather conditions including sun and rain. The life of the mats will be enhanced if the boat is stored either covered or indoors.

It should be treated the same way you would treat vinyl marine seats or carpet in a boat. Excessive exposure to sunlight will decrease the life of the mats and result in fading.

Focused Refracted Light

Much like a magnifying glass, certain things on a boat can cause focused light, which can result in blushing or burning of the surface on your swim platform mat. This is a very rare occurrence when the boat is in use, but if the boat is docked, on a lift or trailer, and the sun is at the correct angle, damage can occur. The best way to avoid this is to cover the boat when you are not using it.

If discolorization happens to your mats, they likely are not ruined. The damage usually looks like a wet spot (a little darker) and over time, this will blend or weather back into the rest of the mat area and become less noticeable.

Material Note

The swim platform mat foam has a “memory.” If you notice an indent in the mats when you remove your cover from the support pole or any other area where something with some weight has been sitting for an extended period, that mat will rebound over a short period of time back to its original shape.



Teak Swim Platform

Your Cobalt boat may be equipped with a teak swim platform. (See *additional details about teak care in the previous Cabinetry and Wood section of this chapter.*) To keep teak in top condition, clean it occasionally with a teak cleaner and re-oil it at least once a season. Follow the manufacturer’s instructions and warnings carefully. Some cleaners and oils may damage gel coat, vinyl, stainless or aluminum. Avoid using rust-producing steel wool pads when cleaning. Materials can be purchased from your authorized Cobalt dealer.

NOTICE

Teak sealers and cleaners can be harmful to other materials. Make sure you thoroughly remove any spills or excess. Teak should not be varnished. The natural oils in teak will cause poor adhesion.



DO NOT store cleaning cloths used to treat teak onboard. Store or dispose of cleaning cloths properly ashore.





Bilge

Check the bilge after every outing and keep the bilge area as clean as possible. Due to the likely presence of water, use a Shop-Vac® or similar device to remove debris from the bilge area. Oil and greasy dirt, in addition to modest amounts of water that may not fully pump on through, will accumulate over time and normally can be removed using soap and water. If necessary, consult an authorized Cobalt dealer for recommendations on special bilge cleaning and absorption products.

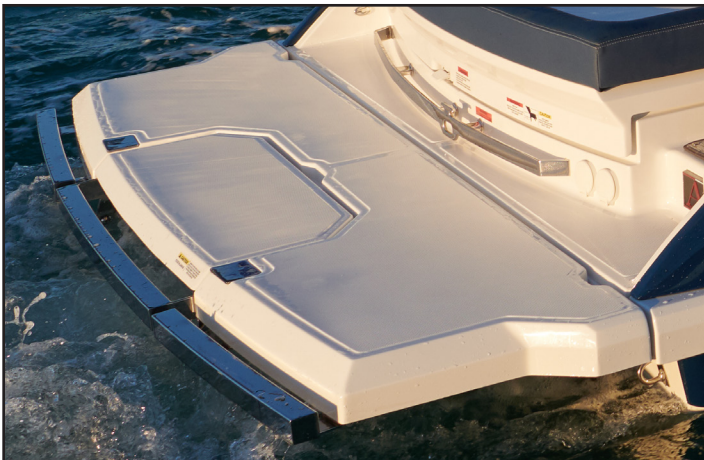

Swim Platform (Non-Teak)

When teak has not been used, Cobalt uses other high-quality materials to construct swim platforms. These durable boards should also periodically receive a thorough cleaning. Use only mild detergents and warm water or marine industry-based cleaners that are approved for use in wet environments.

NOTICE

Avoid using unapproved products in attempting to clean. These will actually accelerate deterioration of the product, rather than protecting it. Such damage is not covered under warranty.



Windshield

To keep the windshield clean, use a non-abrasive glass cleaner applied with a soft cloth. Do not use harsh detergents, solvents, chemicals or dry cloths. These items will scratch the surface.

All the metal hardware, frame extrusions and stanchions should be carefully maintained as well, especially when operated in salt water operations.



Marine Growth

Remember that in various sections of this owner's manual information has been provided about the potential ill effects that can result in damaged equipment if attention is not paid to marine growth.

If marine growth is a problem in the area in which you are boating, it may be necessary to apply anti-fouling paint to the hull to slow growth and prevent gel coat damage. Consult an authorized Cobalt dealer for recommendations on how to do this properly.



Stationary Arch with Awlgrip Topcoat

Your Cobalt boat may be equipped with a fixed, stationary arch with Awlgrip Topcoat.

It is difficult for dirt, grime and grease to adhere to Awlgrip 2000 Topcoat; however, over time, a buildup of dirt, grease and other contaminants can cause the finish to appear dull.

Maintaining your topcoat with a combination of Awlwash and Awlcare will deliver the best results.

The mirror-like gloss can be easily maintained by following these instructions:

DO:

1. Wash the surface regularly with Awlwash 73234 and water. Regular cleaning will avoid buildup, which can slowly attack the topcoat, prematurely aging the coating.
2. Use only mild solvents to remove stubborn stains. Awlprep T0008, mineral spirits, xylene, and kerosene are acceptable for use on Cobalt's topcoat. Be certain to use with special care any flammable items and their fumes, keeping them at distance from flame sources. Apply solvents with soft, clean cloths. Wipe up solvent quickly. Do not allow solvent to



dry on the surface or puddle and soak into the surface. Wash these areas with mild detergents and water to remove solvent residue.

3. Always thoroughly rinse all surfaces with fresh water after cleaning with detergents or solvents. Latent solvent residue can attack the topcoat, while detergent residue will attract dirt.
4. Use distilled white vinegar and hot water to remove stubborn salt stains.
5. Use Awlcare 73240 by hand only to remove stubborn diesel soot stains.

DO NOT:

1. Do not wax.

General:

Wax buildup ages and yellows very rapidly, creating the need to maintain the wax and causing the topcoat to appear yellow. Wax buildup also attracts dirt, increasing maintenance. Because waxing will help maintain the gloss, especially those areas which have been buffed or polished, some boat owners will choose to wax. Remember, waxing leads to having to maintain the wax from the initial application onward.

If you choose to wax, do not wax areas unless they are dull or hazed.

2. Do not use abrasives, scratch pads or polishing compounds. Scratching the surface gives dirt a place to cling while wearing out the resin layer. Using abrasives of any kind will reduce the overall life of the finish and voids the Awlgrip Limited Warranty.
3. Do not allow contact between the topcoat and teak

cleaners. Most teak cleaners contain acids or caustic agents that stain and discolor the topcoat.

4. Do not use strong solvents (e.g., lacquer thinner, M.E.K., acetone) to clean the topcoat.
5. Do not allow wet equipment (e.g., seat cushions, coils of line, or coolers) to trap and hold moisture against the topcoat. This condition can result in blistering or delamination of the Awlgrip topcoat.
6. Do not use acrylic Teflon® (*Teflon is a registered trademark of E.I. du Pont de Nemours and Company*) coatings over an Awlcraft 2000 finish. Use of these coatings voids the Awlgrip Limited Warranty.
7. Do not “shrink wrap” or tightly bind the top coat surfaces with plastic wrappings.

When tarping a boat for storage, the cover system should be ventilated to allow the coating system to “breathe.” Covers and tarps, whether synthetic or natural fiber, should not be pulled tight to surfaces painted with Awlcraft 2000 Topcoat. This condition can trap and hold moisture on the surface and result in loss of gloss, blistering or delamination of the topcoat.

Caution should also be used to ensure the tarp does not chafe against the Awlcraft 2000 surface. Such chafing, especially when accompanied by airborne dirt, can abrade the surface and cause premature loss of gloss.

NOTICE

Failure to follow the instructions for care of the Awlgrip Topcoat as explained in this owner’s manual will void both the product’s and Cobalt’s limited warranties.

SCHEDULED MAINTENANCE AND SERVICE

Your Cobalt boat may not include all of the features described in this section based on the options available and how your boat was built. If you have questions about component care beyond what is provided here, contact your authorized Cobalt dealer.

Steering System Maintenance Schedule



WARNING

The Teleflex® steering system must have all attaching hardware, bolts and nuts retorqued according to the manufacturer’s specifications after a few hours of operation and at regular intervals thereafter. Loose or missing hardware may cause failure of the steering system, resulting in injury or death. Due to the specific requirements to maintaining the steering system in optimum and safe functionality, have your authorized Cobalt dealer service the steering system at regular intervals.

Important General Information

Use the checks and maintenance information outlined in the section along with service information contained within the individual component operator’s manuals supplied with your boat. It is extremely important that you read and understand the periodic maintenance tasks outlined in your operator’s manuals (propulsion unit, generator and other accessories) because those maintenance tasks are not repeated in this manual.

Use the following chart to establish your maintenance routine. Detailed information concerning the task is listed in this section.

Frequency	Task
Break-in	Refer to propulsion unit operator's manual and the generator operator's manual, if equipped.
Before Every Use	Test operation of carbon monoxide detectors. Check fluid levels. Check seacocks for leaks and ensure handles are secure. Check seawater strainers for leaks and accumulation of debris. Check generator's fuel/water separator, if equipped. Check exhaust system for leaks. Check fuel system for leaks. Check fire extinguisher. Check battery charge. Check equipment fasteners. Check there is sufficient fuel in the fuel tank for the outing.
After Each Outing	Check components. Note how much fuel and battery charge were used. Give the boat a good general cleaning.
Every 50 Hours	Clean seawater strainers, if equipped. Inspect propellers for damage.
Every 100 Hours	Test for proper operation of the ignition safety switch. Clean bilge area.
Monthly	Test GFCI outlets, if equipped. Check self-sacrificing anodes.
Quarterly	Have your authorized Cobalt dealer perform scheduled Maintenance as outlined in this section.

Break-In

Careful break-in allows internal engine components to “seal” properly, resulting in maximum engine life and performance. Refer to the propulsion unit operator's manuals, or the engine chapter of this owner's manual, for manufacturer's break-in requirements.

If the boat is equipped with a generator, refer to its manufacturer's operating manual for information regarding the break-in requirements.



Before Each Use

1. Test for proper operation of the carbon monoxide detector (if equipped); refer to the carbon monoxide detector operator's manual.
2. Check fluid levels of the fresh water tank (if equipped), waste holding tank (if equipped) and trim tab reservoir.
3. Check the air conditioning and generator (if equipped) seacocks and hoses for leaks. If you notice a leak, do not

operate until you can see your authorized Cobalt dealer.



- **Seacocks can be replaced only when the boat is out of the water.**
 - **Make sure a seacock is in the CLOSED position before replacing a hose.**
4. Check the air conditioning and generator seawater strainers for leaks and accumulation of debris.
 - If a hose is leaking or damaged, close the appropriate seacock. Consult your authorized Cobalt dealer for repairs.
 - If debris is seen within the container, close the appropriate seacock and remove the strainer cover. The sea strainer serves the purpose of keeping debris from entering the raw water-cooling system and causing eventual engine failure. As with any kind of strainer, it is necessary to regularly clean it so that water can flow unimpeded. Lift the strainer from the container and

thoroughly clean it. If the container is full of sediment, remove the plug at the bottom of the container and allow water to drain into the bilge. Remove the container and clean any sediment. Install the container and plug. Install the strainer in the container and secure the cover. Open the seacock and check for leaks.

 **CAUTION**

The seacock must be in the CLOSED position before servicing a strainer.

NOTICE

Continuing to operate a boat that is overheating the engine and drivetrain will result in engine failure eventually. Boat operators should routinely review the engine temperature information. Ignoring or failing to take proper steps to reduce the engine temperature, resulting in damage, is not covered under the warranty.

5. Start the engine(s) and the generator (if equipped). Check all exhaust systems for leaks. If you notice a leak, do not operate the boat until you see your authorized Cobalt dealer and have the system(s) corrected.
6. Check all fuel lines and connections at fuel tanks, engines and the generator for leaks. If you detect a fuel leak, immediately see your authorized Cobalt dealer. Never start or operate a boat in the presence of a fuel leak. Fumes can cause an explosion and/or fire, which may lead to death or serious injury.

 **DANGER**

Avoid the risk of fire or explosion. DO NOT operate your boat if a fuel leak is detected. All fuels are combustible. A fuel leak must be repaired before starting the engine(s) or the generator (if equipped).

7. Check the portable and automatic fire extinguishers for proper charge.
8. Check the battery charge of both engine batteries. Be sure that the batteries can start the engine(s) and the generator, if equipped, before proceeding on your outing.

If the posts show signs of corrosion or other debris, remove the battery and clean carefully. To do so, follow these steps:

1. Turn the engine **OFF**, as well as any systems that are operating on the boat.
2. Make sure the battery switch is in the **OFF** position.
3. Loosen and remove the negative (-) black terminal connection first. If you are using a wrench for this process, be careful to avoid touching the positive (+) red terminal connection as you may receive an electrical shock as a result.

4. Next, loosen and remove the positive (+) red terminal connection.
5. Disconnect the hold downs that are holding the battery in place.
6. Remove the battery.
7. Using a battery terminal cleaner, carefully clean the corrosion/debris from the battery posts.
8. Using a baking soda and water mix, clean the battery case, taking care to avoid splashing any of the solution inside the battery vents. Rinse with clear water again, avoiding the vents.

 **CAUTION**

Inside the battery is an electrolyte fluid that allows the chemical reaction to provide power. The fluid is comprised of several components, one of which is sulfuric acid. As with most acids, this is caustic and corrosive. If it comes in contact with skin, immediately flush the area with copious amounts of fresh, clean water. Follow up with medical assistance.

- A battery terminal brush may be necessary to remove corrosion from the inside of the battery terminals. Use the same type of baking soda and water mix and rinse with fresh water. Dry with a clean rag.
- Check the box in which the battery is held to be certain that it is not showing signs of corrosion or dirt. Clean, if necessary, as with the above instructions for cleaning the battery. Be sure that the holding box is dry prior to reinstalling the battery.
- Repeat the steps with the second battery.
- After placing the battery back in the holding box, reconnect the hold down. Then reconnect the positive (+) red battery cable connection first. Follow with the negative (-) black battery cable connection.
- Tighten both terminals and then coat with a thin covering of marine dielectric grease. Be sure that the positive terminal rubber boot completely covers the terminal.

 **DANGER**

If it becomes necessary to re-charge a battery from an external source, DO NOT attempt to charge using automotive battery cables or use another boat battery as the source for charging. Some amounts of hydrogen gas are emitted during the charging process. This can be very dangerous. It is critical to keep all sparks, including smoking cigarettes, lighters, or any type of flame, well away from a charging battery. Use an optional battery charger sold by authorized Cobalt dealers, or a similar aftermarket battery charger. Using the wrong type of charging procedure or improperly charging a battery can result in an explosion and/or fire that could lead to serious injury or death.

9. Check equipment for loose or missing fasteners. Be sure all fasteners are installed and properly tightened before operating the equipment.
10. Fuel levels should be noted prior to an outing. Cobalt recommends starting all outings with a full tank and returning to shore to refuel regularly during a full-day's recreation as allowing fuel to fall too low in the tank can adversely affect the propulsion operation or could potentially strand the boat if fuel runs out.



After Each Use

Check Components

This is a common-sense approach. If you've been boating in dirty water, cleaning out the sea strainer now instead of waiting until the debris inside it has dried (and therefore becomes more difficult to remove) makes sense. You want to check the propeller to make sure it appears intact, too, especially if you suspect that you may have struck something submerged during the outing. This is an easy check after the boat has been loaded on the trailer and removed from the water.

Check anything else on the boat that did not function as expected during the outing and seek assistance from your authorized Cobalt dealer about any concerns and issues prior to the next outing.

Note How Much Fuel and Battery Charge Were Used

Cobalt recommends keeping a chart or binder with information from your outing. If you note the conditions during the outing, the length of time, and the final readings, you'll have a much better idea of normal operations. That gives you the clues you need when readings are different, or you are anticipating an outing that will be different and you need to prepare for those conditions.

Give the Boat a Good General Cleaning

(Outlined in the *Care* information that precedes this section.)

As noted earlier, ongoing care is important. Read that section to determine the normal expectations regarding routine care. Read the salt water maintenance information that appears earlier in this chapter. Even boating in "clean" water, you add protection and quality care for your boat by following the cleaning requirements. The same components that need added protection from salt/brackish water will also retain their luster and live longer if the same attention is applied to them after operation in fresh water.



Every 50 Hours

1. Be sure to clean the seawater strainers as described in *Before Each Use, Step 4*, above.
2. Check the propellers for damage. If bends, cracks or other damage is found, consult your authorized Cobalt dealer for service. Do not continue to use damaged propellers as they may damage the drive unit(s) over time.



Every 100 Hours

Clean the bilge area. Make sure all drain passageways are clear. Refer to *Bilge* in the *Care* information earlier in this section of the owner's manual.



Monthly



The emergency safety switch and lanyard prevent the boat from becoming runaway if the operator is accidentally thrown from the helm. To test the system, with the engine(s) running, pull the lanyard off the emergency safety switch. The engine(s) must stop running. If the engine or engines do not stop running, immediately see your authorized Cobalt dealer for service. Never run your boat with an improperly operating emergency safety switch.

1. Test the FGCI outlet circuit breaker feature, if equipped. Push the TEST button on each outlet. Power should be interrupted to all the outlets onboard. Press the RESET button to restore power. If power is not interrupted, consult your authorized Cobalt dealer.
2. Check the condition of all self-sacrificing anodes. If an anode shows deterioration of 50% or more, it must be replaced. Refer to the propulsion unit operator's manual for additional information, as well as the salt water care and maintenance information provided earlier in this section of the owner's manual.

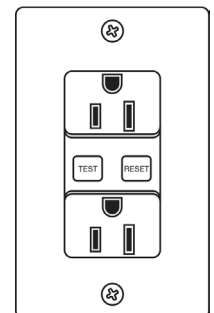

Quarterly

Have your authorized Cobalt dealer perform the following scheduled maintenance (in addition to the two steps listed above under *Monthly*):

1. Clean the fresh water filter (if equipped).
2. Fill, pressurize and inspect the fresh water system (if

- equipped) for leaks and proper component operation.
3. Inspect the steering, shift and throttle systems for proper operation.
 4. Check all batteries for proper electrolyte level.
 5. Check the trim tab pump fluid level.



Unscheduled Maintenance

Issues can arise with components at any time. Do not ignore malfunctions, collisions with debris or groundings, or anything occurring that is outside the normal operating range or expectations. Any matter that occurs requires your immediate attention; your authorized Cobalt dealer also stands ready to help identify and correct your concerns.



Engine/Propulsion/Cooling System

If an unexpected issue occurs with the engine, propulsion unit or the cooling system between the scheduled maintenance cycles, immediately notify your authorized Cobalt dealer. Do not allow such situations to go unattended. What may be a minor repair if ignored could become a major repair.



Electrical System

Have an authorized Cobalt dealer repair all electrical problems. Due to the complexity of a boat's wiring and the necessity of a properly functioning electrical system to ensure the propulsion system works properly and does not strand a boat, every electrical concern should be taken seriously.



Whenever checking for electrical problems, use extreme caution. An electrical spark could ignite fuel fumes and cause a fire or explosion.



Fuel System

DO NOT operate a boat if you suspect or detect a fuel system issue. Upon discovery of a fuel system concern, immediately notify an authorized Cobalt dealer for repair. Never operate a boat if you suspect a potential fuel/fume issue exists.



DO NOT operate your boat when a fuel leak is detected. All fuels are combustible. A fuel leak must be repaired before starting the engine(s) or the generator (if equipped.)



Water System (if equipped)

Fresh Water

Before departing on a cruise, check the level of fresh water onboard. Fill the fresh water tank and the proper operation of the fresh water system. If a problem is found, have it repaired at your earliest convenience.

Cleaning and Disinfecting the Fresh Water System

For potable (drinking) water, follow these steps to disinfect the water tank and system before the first use and prior to the boating season every year. Repeat the process as often as needed.

These steps involve filling the fresh water tank with a solution of household bleach and water (see below) and running the solution through each faucet, and then letting it stand for at least three (3) hours.

Finally, flush the system once or twice to remove any residual taste and smell of bleach.

1. Start with a nearly full fresh water tank.
2. Turn the water heater off (if applicable) and let the water cool.
3. Dilute four (4) tablespoons of household bleach for each ten (10) gallons of tank capacity into one (1) gallon of water.
4. Add the chlorine/water solution to the water tank. (**Never pour straight bleach into the fresh water tank.**)
5. One faucet at a time, let the chlorinated water run through them for one (1) or two (2) minutes. (Hot water will take longer due to added time to run through the hot water tank.) You should be able to smell the chlorine. (To be sure that you are circulating the cleansing water throughout the fresh water system, be certain you are using the water pump and not an external water supply.)
6. Top off the fresh water tank and let stand for at least three (3) hours. Overnight is better.
7. Completely drain the system by flushing the faucets for several minutes each. Open the fresh water tank drain valve to speed up emptying the tank, and open the hot water tank drain plug (if applicable) and drain until it is empty.
8. Close all valves and faucets and install all drain plugs.
9. Fill the water tank with fresh water.
10. Flush the faucets for several minutes each, repeating until the tank is again empty. (As noted above, be sure you are using the water pump and not an external water supply.)
11. Fill the tank again. The water should now be safe to drink. If you are uncertain or if the chlorine odor is too strong, you can repeat the freshwater flush.



Gray Water

Periodically check the level of waste water in the waste tank. Have your waste tank pumped out when needed and be sure that the waste system is always operating properly. Additional details appear elsewhere in this owner's manual.

STORAGE AND WINTERIZATION

Lifting the Boat

To prevent structural damage to your Cobalt boat, the proper procedure must be used when lifting your boat. Remove boats from the body of water only by way of a trailer that has been designed for your boat or by lifting slings. Incorrect trailer fit or any lift that is not properly rated for the weight of the boat means that there will be undue stress on the boat's structural unit. Over time, these components could potentially fail, which would not be covered under warranty.

NOTICE

Never use the tower or arch as part of the lifting process. These components are not designed to be utilized at any time or any point in the lifting process. Never lift the boat with any water in the ballast or bilge systems of the boat. The additional weight could cause failure also, and such resulting damage is not covered under the limited warranty.



Using Lifting Slings

When using slings, an appropriately rated capacity overhead hoist is required. Slings must be the flat, wide-belt type. Do not use cable-type slings. The spreader bars used with the slings must be wide enough to avoid pressure to the gunwales. Multiple slings at least six (6) inches wide by twenty (20) feet should be used.

If your Cobalt boat has sling location decals on each side of the hull to indicate where each sling should be located, use them to position the slings. If your boat does not have decals, contact your authorized Cobalt dealer to identify the proper location for slings. Slings may need to be adjusted forward or aft for your particular boat.

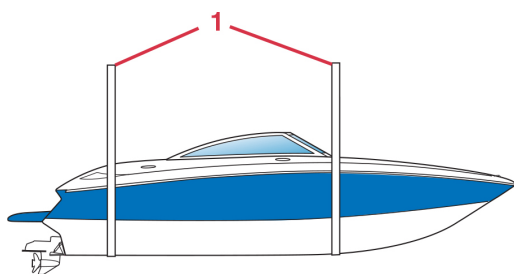

1 – Flat, wide-belt sling

COB_0080_A



Storage Cradle

Use only a storage cradle (or the trailer designed for your boat) to store your boat when it is not in the water. A storage cradle or your boat's trailer will provide proper support and prevent stress on the hull.

A storage cradle must provide proper support to the boat, meaning the boat cannot be supported by resting the hull on the keel. There can be no gaps between the hull and the cradle supports. Support of at least five hundred (500) square inches is required on boats of less than twenty-five feet (25'), and at least six hundred (600) square inches on boats greater than twenty-five feet (25').

Position the storage cradle as close to the sling tag locations as possible. Use caution not to damage any underwater fittings.

Protect all underwear gear protruding from the boat hull from damage. None of these components is rated to support any of the boat's weight. The storage cradle must completely touch the hull for proper support. Avoid any gaps between the cradle and the hull.

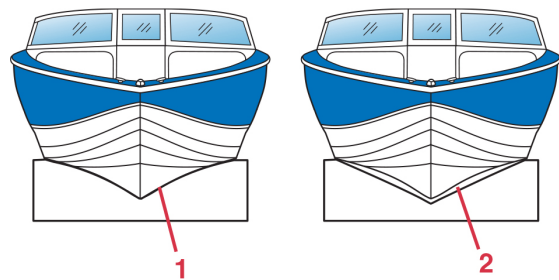

1 – Hull completely on cradle — right
2 – Gap between hull and cradle — wrong

COB_0081_A

Store your Cobalt boat on a storage cradle with the bow slightly elevated, the same attitude as if the boat were floating at rest. If the boat is stored with the bow down, moisture will not be able to move to the engine bilge area and out of the boat.

Remove the transom drain plug. (Cobalt suggests placing drain plugs in a clear, plastic bag and storing at the steering wheel or driver's helm to help remember to reinstall the plugs when the boat is recommissioned.)

Be sure that all compartments in the bilge completely drain. Mold and mildew may form as a result of the inability of moisture to escape. In certain geographic regions, particularly when boats are stored in unheated areas, water can freeze inside the lines or bilge and cause damage that is not covered under warranty.



Storage/Winterization General Information

Preparing for winter lay-up is important. In frigid zones, be particularly attentive to items that can be damaged by freezing. Freeze damage is not covered by warranty.

The following items require special attention for winterization. Your Cobalt boat may not include all the features described. Have your authorized Cobalt dealer perform winterization procedures for the following:

- Engine cooling and exhaust systems (review storage and winterization requirements as noted in the engine/propulsion unit's owner's manual)
- Fuel system
- Batteries
- Air conditioning
- Generator and muffler (review storage and winterization requirements as noted in the propulsion unit's owner's manual)
- Waste water system
- Fresh water system
- Gray water system
- Cockpit heater

After the boat has been properly positioned on a storage cradle, thoroughly wash the hull, deck and interior compartments. Allow a couple of days of air drying before covering the boat, store all cushions in the **OPEN** position and open all storage areas. This will help prevent mold/mildew from forming. Perform preventive maintenance to the interior and exterior of your boat, following the information in this section of the owner's manual.

Cover the boat with the mooring cover. If a temporary poly cover, such as shrink wrap, is used, your authorized Cobalt dealer must install several vents to provide adequate ventilation to prevent mold or mildew.

NOTICE

For stowage, Cobalt recommends an optional mooring cover of 100% SharkSkin™ polyester. **DO NOT** use your tonneau cover for long-term storage. These canvases were not designed for long-term storage and do not provide good extended protection for your boat. Adequate ventilation is not possible, and mold/mildew will form. For more information on appropriate covering for long-term storage, see your authorized Cobalt dealer.



Reactivating the Boat After Storage

Have your authorized Cobalt dealer prep your boat for the upcoming boating season. There are many systems that require special attention to ensure your boat is in proper operating condition.

- Carbon monoxide detector(s), if equipped
- Fuel and exhaust systems
- Engin's cooling exhaust and lubrication systems
- Air conditioning
- Generator and muffler
- Fresh water system
- Waste water system
- Gray water system
- Batteries

It is very important that all fuel systems and exhaust systems be thoroughly inspected and repaired, if necessary, before operating the boat. Also, any accessory exhaust systems must be in proper operating condition.

Be sure to check all onboard equipment for loose or missing fasteners. Do not operate the equipment if the fasteners are loose or missing.



Inspect and repair the fuel system as necessary. Failure to inspect the fuel system, which could allow fuel leaks to go undetected, can contribute to a fire or explosion hazard.



Exposure to carbon monoxide (CO) can cause severe injury or death. CO is a naturally occurring by-product of gasoline engines. CO is colorless, odorless and quickly dangerous. Direct and prolonged exposure to CO will cause brain damage or death, among many adverse effects. Signs of exposure to CO include nausea, dizziness and drowsiness. Avoid exposing your passengers or yourself to carbon monoxide.

Warranty Statement



COBALT CERTIFICATE OF LIMITED WARRANTY

Subject to the terms, conditions, and exclusions in this warranty, Cobalt Boats, LLC, a Delaware limited liability corporation doing business as Cobalt Boats (“Cobalt”), warrants to the original retail purchaser (and any subsequent owner) (“Owner”) of a new Cobalt boat purchased from an authorized Cobalt dealer for personal, non-racing and non-commercial use, as follows:

Ten (10) Year Limited Transferable Warranty on Hull and Deck. Cobalt warrants to the Owner that the hull and deck, including floor, stringers, bulkheads, motor mounts, transom and deck/hull joints of a new Cobalt boat are free from structural defects in material and workmanship under normal, non-racing and non-commercial use for a period of ten (10) years from the date of delivery to the original retail purchaser.

Five (5) Year Limited Transferable Bow to Stern Component Warranty. Cobalt warrants that the upholstery, canvas, components (excluding hull and deck structural components), where purchased or manufactured by Cobalt, with respect to a new Cobalt boat are free from structural defects in material and workmanship under normal, non-racing and non-commercial use for a period of five (5) years from the date of delivery to the original retail purchaser.

Three (3) Year Limited Transferable Warranty on Gelcoat Finish. Cobalt warrants that the gelcoat finish, with respect to a new Cobalt boat is free from defects in material and workmanship under normal, non-racing and non-commercial use for a period of three (3) years from the date of delivery of such Cobalt boat to the original retail purchaser. Because local area operating conditions and customer care have an effect on gelcoat finishes, the gelcoat finish warranty does not cover (1) damage or deterioration (for example: fading, oxidation, discoloration) due to in-water storage or improper care of the gelcoat surface; or (2) deterioration (for example: fading, oxidation, discoloration) to the gelcoat finish of any Cobalt boat with colored (non-white) gelcoat located below the static waterline; or (3) blisters due to in-water storage without the proper application of a marine barrier coating to the bottom of the hull.

THERE ARE NO EXPRESS WARRANTIES OTHER THAN THE ABOVE LIMITED EXPRESS WARRANTIES. TO THE EXTENT APPLICABLE, ANY IMPLIED WARRANTIES, INCLUDING ANY IMPLIED WARRANTIES OF MERCHANTABILITY OR FITNESS FOR PARTICULAR PURPOSE, WILL NOT EXTEND BEYOND THE DURATION OF THESE EXPRESS WRITTEN WARRANTIES. Some states do not allow limitations on how long an implied

warranty lasts, so the above limitation may not apply to you.

Exclusions. The above described limited warranties do not apply (1) if such Cobalt boat has been used at any time commercially, industrially, for racing or other competition or for revenue producing purposes; (2) to engines, outdrives, propellers, controls (each of which may be separately warranted by the engine manufacturer thereof); (3) engines, outdrives, propellers, controls, batteries, trailers, equipment or accessories installed by persons or parties other than Cobalt or an authorized Cobalt dealer; (4) windshield leakage, rainwater leakage, windshield or window damage or breakage; (5) deterioration or damage, fading or shrinkage of upholstery, carpet or canvas; (6) damage related to the alteration or modification of such Cobalt boat with any structurally affecting addition, component or accessory not specifically in accordance with Cobalt’s specifications or offered as an option by Cobalt; (7) damage, deterioration (for example: fading, oxidation, corrosion) of surface finishes, vinyls, fabrics, aluminum and stainless steel finishes; (8) damage or failures caused by operation of the Cobalt boat outside of the maximum horsepower specifications recommended by Cobalt; (9) damage or failure related to repairs made by any service provider not approved by Cobalt; (10) damage (for example: scratches, fading, oxidation, discoloration) to the gelcoat finish; (11) deterioration (for example: fading, oxidation, discoloration) to the gelcoat finish of any Cobalt boat with colored (non-white) gelcoat located below the static waterline; (12) damage or failure related to alteration, modification, misuse, neglect, negligence, accident or failure to provide reasonable care and maintenance of such Cobalt boat; or (13) if the Cobalt Boat has been purchased from an unauthorized third part such as—but not limited to—a bank (repossession), insurance company, salvage yard, or auction.

Remedies.

General. During the applicable limited warranty period, as set forth above, covered warranty repairs shall be made and any replacement parts or components used as part of such warranty repairs shall be provided without charge by an authorized Cobalt dealer or, at the option of Cobalt, by Cobalt at its plant in Neodesha, Kansas, or at a facility specifically authorized by Cobalt. All warranty repairs and replacement parts or components shall be subject to the authorization of factory trained personnel of Cobalt. Transportation to and from an authorized Cobalt dealer, and/or to and from the Cobalt plant in Neodesha, Kansas, for warranty repairs, shall be at Owner’s expense.

Service Assist Service Agreement (see Addendum A).

Service Assist is not covered under this limited warranty. Service Assist is covered under the separate Service Assist Service Agreement.

The rights and benefits granted under the above described limited warranty extend to (1) the original retail purchaser of a new Cobalt boat, and (2) any owner of such Cobalt boat during the applicable warranty period, commencing with the date of delivery of such Cobalt boat to the original retail purchaser, provided that such limited warranty is validated, as set forth herein. **COBALT’S ONLY RESPONSIBILITY, AND THE OWNER’S ONLY REMEDY, IS AS DESCRIBED IN THIS WARRANTY. COBALT SHALL NOT BE LIABLE FOR INCIDENTAL, CONSEQUENTIAL, INDIRECT OR SPECIAL DAMAGES.**

Some states do not allow the exclusion or limitation of incidental or consequential damages, so the above exclusions may not apply to you. This warranty gives you specific legal rights, and you may also have other legal rights which vary from state to state.

How to Obtain Warranty Service. To validate the above described limited warranty, (1) the authorized Cobalt dealer must complete the warranty registration process with Cobalt Boats at 1715 N. 8th Street, Neodesha, KS 66757, within ten (10) days after purchase of a new Cobalt boat, and (2) any subsequent owner of a Cobalt boat during the applicable limited warranty period must give written notice of the acquisition of a Cobalt boat to Cobalt within ten (10) days after such purchase. Notification of any warranty claim arising within the applicable warranty period, as set forth above, must be made in writing by the owner of such Cobalt boat or by an authorized Cobalt dealer to Cobalt within thirty (30) days after the discovery of the alleged basis for any warranty claim. With respect to any condition for validating a limited warranty or obtaining any remedy, the authorized Cobalt dealer is Owner’s agent, and Owner is solely responsible for and bears the risk for the authorized Cobalt dealer’s failures.

ADDENDUM A—SERVICE ASSIST SERVICE AGREEMENT

In consideration of the purchase of a new Cobalt boat from an authorized Cobalt dealer for personal, non-racing, and non-commercial use, for the term of this agreement Cobalt Boats, LLC (“Cobalt”) agrees to provide to the original retail purchaser or any subsequent owner (each an “Owner”) of such Cobalt boat, for which the registration process under Cobalt’s Certificate of Limited Warranty has been completed, the services described in this agreement.

Obligation. Subject to the conditions and limitation of this agreement, if (1) Owner makes a valid claim under either the Cobalt Five (5) Year Bow to Stern Component Warranty or any express warranty made by the engine manufacturer with respect to the engine or powertrain of such new Cobalt boat (the “Applicable Warranties”); (2) Owner incurs costs for on-water towing, hoist/lift-out, haul-out, or dockside repair call (“Covered Services”) in association with such claim; and (3) the Applicable Warranties claim is made and Covered Services costs are processed through an authorized Cobalt dealer (“Dealer”), then Cobalt will reimburse Owner for or pay such costs.

Conditions. As a condition for Cobalt’s obligations under this agreement, if Covered Services are provided by anyone other than a Dealer, Owner must provide the following documentation (as applicable) to the Dealer prior to the time the Dealer submits the Applicable Warranty claim:

- Copy of Towing, Hoist/Lift Out, Haul-Out or Dockside Repair bill
- Copy of warranty claim to the engine manufacturer

Limitations. Cobalt’s liability under this agreement will not exceed a maximum of \$100 per claim. **EXCEPT AS PROHIBITED BY APPLICABLE LAW, COBALT MAKES NO WARRANTIES, EXPRESS OR IMPLIED, UNDER THIS AGREEMENT OR REGARDING THE SERVICES, INCLUDING WITHOUT LIMITATION, THE IMPLIED WARRANTIES OF MERCHANTABILITY OR FITNESS FOR A PARTICULAR PURPOSE. COBALT WILL NOT BE LIABLE FOR INCIDENTAL, CONSEQUENTIAL, INDIRECT OR SPECIAL DAMAGES.** Some states do not allow the exclusion or limitation of implied warranties or limitation of remedies for their breach, so the above provision may not apply to you. This agreement gives you specific legal rights, and you may also have other legal rights which vary from state to state.

Term. This agreement begins on the original purchaser delivery date of the new Cobalt boat and is effective through the end of the warranty periods for the Applicable Warranties.

Assignment. This agreement is transferable to subsequent Owners within the term of this agreement. Otherwise,

Owner may not transfer or assign any of Owner's rights, title, or interest under this agreement.

General. This agreement embodies the entire understanding of the parties. This agreement cannot be changed or modified except in writing signed by an authorized officer of Cobalt. This agreement is governed by the laws of the

State of Kansas, ignoring the rules on conflicts of law. No failure or delay by Cobalt to exercise any right or remedy will operate as a continuing waiver. Headings used in this agreement will have no legal significance. This agreement will not be construed against a party simply because the party may have drafted such provision.

CALIFORNIA EVAPORATIVE EMISSIONS CONTROL SYSTEM WARRANTY STATEMENT

Your Warranty Rights and Obligations

The California Air Resources Board is pleased to explain the evaporative emission control system's warranty on your Cobalt Boat. In California, new spark-ignition marine watercraft (SIMW) must be designed, built, and equipped to meet the State's stringent anti-smog standards. Cobalt Boats, LLC must warrant the evaporative emission control system on your boat for the period listed below provided there has been no abuse, neglect or improper use of your SIMW.

Your evaporative emissions control system may include parts such as: canisters, carburetors, clamps, connectors, filters, fuel caps, fuel lines, fuel tanks, valves, vapor hoses, and other associated evaporative emissions control system components.

MANUFACTURER'S WARRANTY COVERAGE:

This evaporative emission control system is warranted for two years. If any evaporative emission-related part on your SIMW is defective, the part will be repaired or replaced by Cobalt Boats, LLC.

OWNER'S WARRANTY RESPONSIBILITIES:

- As the boat owner, you are responsible for performance of the required maintenance listed in your owner's manual. Cobalt Boats, LLC recommends that you retain all receipts covering maintenance on your boat, but Cobalt Boats, LLC cannot deny warranty solely for the lack of receipts.
- As the boat owner, you should however be aware that Cobalt Boats, LLC may deny you warranty coverage if your spark-ignition marine watercraft or a part has failed due to abuse, neglect, or improper, maintenance or unapproved modifications.

- You are responsible for presenting your boat to a Cobalt Boat, LLC distribution center or service center as soon as the problem exists. The warranty repairs should be completed in a reasonable amount of time, not to exceed 30 days. If you have a question regarding your warranty coverage, you should contact Cobalt Boats, LLC at 1-(620) 325-2653.

The California evaporative emissions control system warranty covers the following list of components:

- (1) Canister Mounting Brackets
- (2) Carbon Canister
- (3) Carburetor Purge Port Connector
- (4) Clamps*
- (5) Control Cables*
- (6) Control Linkages*
- (7) Control Solenoids*
- (8) Control Valves*
- (9) Electronic Controls*
- (10) Fuel Cap
- (11) Fuel Line
- (12) Fuel Line Fittings
- (13) Fuel Tank
- (14) Liquid/Vapor Separator
- (15) Pressure Relief Valves*
- (16) Purge Valves
- (17) Vacuum Control Diaphragms*
- (18) Vapor Hoses
- (19) All other parts not listed that may affect the evaporative emissions control system

**Your craft may or may not be equipped with these components.*

Troubleshooting, Logs and Index



TROUBLESHOOTING

If any of the following issues cannot be rectified by using the suggested remedies, take the boat to an authorized Cobalt dealer for assistance. **Do not attempt to correct problems by methods not recommended in this troubleshooting guide.** Utilizing other attempts to correct issues could result in additional problems or damage to a system, which would not be covered under warranty.



Handle fuel and fuel elements such as the fuel pumps and fuel lines with extreme care. Fuel is flammable. Fumes are even more flammable and dangerous. Never have open flame in the region of any part of the fueling system.



Electrical system malfunctions can cause shock hazards, which can be serious, even fatal. Always check for electrical activity prior to attempting to troubleshoot or correct any part of the electrical system.



Battery acid can cause serious injury, particularly to the eyes and skin. Avoid contact, but if it occurs, be sure to flush contact areas with copious amounts of water and seek immediate medical attention.



Disconnect the battery cables at the battery before checking or adjusting engine and electrical components.

General

Issue:

The boat will not start.

Consider:

- Verify that the battery switch is ON.
- Verify that the battery is fully charged and the battery connections are secure.
- For outboards, check that the starter connections are tight. If the solenoid clicks when attempting to start the engine, check the battery connections. If the condition persists, see an authorized Cobalt dealer.
- Be certain the Emergency Safety Stop Switch is attached to the connection point on the driver's panel and to the boat operator.
- Be sure that the shifter/throttle device is in the neutral position.
- Be certain the engine electrical system is ON. Generally, this requires turning the ignition key ON or pressing the ON button.
- Verify the engine circuit breaker has not tripped.

- It is possible the display is in a "sleep" mode. Press a key or touch the screen to see if the affected display activates.
- Refer to the propulsion unit owner's manual.
- If the engine turns over but will not start, check the fuel system, i.e., that fuel valves are open or if the fuel may be contaminated (more likely when the fuel has been sitting in the tank for an extended period of time).
- If none of these suggestions correct the situation, see an authorized Cobalt dealer.

Issue:

The boat will not shift into gear.

Consider:

- When engaging the transmission from neutral either forward or backward into reverse, pull up on the safety collar located directly below the throttle lever knob. The safety collar helps avoid unintentional movement into gear.
- When shifting gears, always do so smoothly and briskly. Being either too hard and slamming the gears, or too tentative is hard on the shifter/throttle system and can result in damage that is not covered under warranty.

Issue:

The engine/drive train is not operating properly.

Consider:

- Refer first to the propulsion unit owner's manual or the *Engine* section of this manual (for boats equipped with the Monsoon engine) for guidance.
- Check the fuel level in the boat to be certain that the engine is not "starving" from lack of fuel or contaminated fuel. Improper fuel can also affect performance.
- Check for engine warning messages on the gauges/display. If any are present, take the boat to the closest authorized Cobalt dealer for evaluation and repair.
- Improper loading, excessive weight on-board, boat rim, excessive bilge water and other issues can affect performance.
- If there was difficulty starting but the engine runs properly after it starts, the issue may be an insufficient battery response. Check with your authorized Cobalt dealer as to whether the battery needs attention or replacement. Use **ONLY** marine-grade batteries!

Issue:

The engine and/or boat vibrates when running.

Consider:

- The propeller may be bent, broken or damaged, throwing off the propulsion balance. Also, check for weeds tangled in the propeller or other debris that may require removal.



Gauges, Switches and Video Screens

Issue:

A gauge or video screen does not light up and work as expected.

Consider:

- Be certain the engine electrical system is ON. Generally, this requires turning the ignition key ON or pressing the ON button.
- It is possible the display is in a “sleep” mode. Press a key or touch the screen to see if the affected display activates.
- Verify that the battery connections are secure.
- Determine if other gauges, switches and/or video screens are operational. If they are, check the circuit breaker panel to determine if the breaker has tripped. Reset. If the circuit continues to trip, the boat must be serviced by an authorized Cobalt dealer as it indicates a recurrent and potentially significant problem. Another cause is a loose electrical connection to the non-working gauge/switch/video screen. This matter should be addressed by an authorized Cobalt dealer.
- If a video screen freezes or displays an unreadable or invalid screen, turn the entire system OFF, including the engine electrical system. Allow a few minutes for the system to re-set itself, and then try rebooting the system. If the issue persists or another issue arises, take the boat to an authorized Cobalt dealer for correction. Where equipped, check the battery isolator switch.



Electrical Systems

Issue:

A boat component that is electrically operated will not operate.

Consider:

- Be certain the boat electrical system is ON. Generally, this requires turning the ignition key ON.
- Verify that the battery connections are secure and that there is sufficient charge and power. See the *Battery* information in this manual for additional details.
- Verify that the circuit breaker has not tripped. If it has, clear the fault and reset it. Recurrent trips are indicative of a problem that requires the attention of an authorized Cobalt dealer.
- Check for loose connections, but do not remove any closeout panels to do so. If a loose connection is suspected but cannot be seen, have the system checked by an authorized Cobalt dealer.
- If the component is electronic, be certain the component is operational. If it requires reception from a satellite, tower or other supplier, Cobalt cannot guarantee that it will receive the signal. It may be necessary to move the boat to another location or body of water, or pay a subscription fee.

Issue:

Accessories will not recharge in the 12-volt receptacle.

Consider:

- Verify that the correct charger was used for the item(s) and that the charger plug-in was fully seated in the 12-volt receptacle.

Issue:

Lights will not come on or are dim.

Consider:

- Verify that the circuit breaker has not tripped. If it has, clear the fault and reset it. Recurrent trips are indicative of a problem that requires the attention of an authorized Cobalt dealer.

Issue:

Generator (where equipped) will not start.

Consider:

- Verify that the battery connections are secure and that there is sufficient charge and power. See the *Battery* information in this manual for additional details.
- Run through the various Electrical Systems potential solutions. If none of these work, seek attention from an authorized Cobalt dealer.

Issue:

No AC power.

Consider:

- Verify that the circuit breaker has not tripped. If it has, clear the fault and reset it. Recurrent trips are indicative of a problem that requires the attention of an authorized Cobalt dealer.
- Check that the ground fault circuit interrupter has not tripped. If suspected, reset the button on the outlet and test. If this persists, see an authorized Cobalt dealer.
- Be certain that the shore/generator selector switch is positioned correctly.



Battery Failure

Often, a battery that will not start the boat requires recharging. Use **ONLY** a marine-approved battery charger. Any other can damage the electrical system, and such damage is not covered under warranty. **NEVER** attempt to “jump” from a vehicle or another boat as there is a potential for overload that could significantly damage the boat’s electrical system, which is not covered under warranty! Read the battery information provided in this manual before undertaking any attempt to replace, use both batteries simultaneously, or replace the battery.



Alarms

Issue:

The low voltage alarm sounds.

Consider:

- Most often, this signals the need to turn OFF and leave OFF the stereo component or similar electronics that require substantial support from the batteries. Start the engine and allow the alternator to recharge the batteries, which will require a fairly short period of time if there is no additional drain occurring during the recharging time. If this does not work, it may be that the battery or batteries are nearing their terminal life span.

Issue:

Another alarm sounds.

Consider:

- These occur when a sensor detects that the engine or transmission temperature range or oil pressure range have exceeded programmed limits. The boat's main system may begin shutting off peripheral activity to retain proper operation as long as possible. It is usually in the operational best interest to return to shore as soon as possible to avoid being stranded. Even if the ranges return to acceptable operating range, this matter should be shared with the service department of your authorized Cobalt dealer to determine the cause and avoid a repeat.



Bilge, Ballast and Plumbing

Issue:

The bilge pumps are not operating.

Consider:

- The bilge pump(s) should operate automatically. If it does not, use the manual switch. If it still does not operate, return to shore **IMMEDIATELY** and terminate the outing. See an authorized Cobalt dealer before the next outing to ensure the bilge pumps are working properly. Failure to pump water out of the bilge can result in the boat swamping. This could result in serious injury or death to those on-board.

Issue:

The ballast pump is not operating.

Consider:

- If the ballast pump does not pump water into the system, and having verified that the electrical system is operational, leave the pump OFF and have it serviced by an authorized Cobalt dealer. If the pump does not pump water out of the system, seek assistance by calling your Cobalt dealer. You should never attempt to tow your boat on a trailer with water in the ballast system as it could cause damage to the trailer, which can result in the driver

losing control while towing. Such activity could result in serious injury or death to anyone in the area.

- Additional information on the bilge and ballast systems can be found in this manual.

Issue:

No water at the sink (where equipped).

Consider:

- The fresh water pump circuit breaker may have tripped or be in the OFF position. Correct the issue and reset so that the breaker is in the ON position.
- Verify that there is water in the fresh water tank.
- The fresh water pump may be defective. See an authorized Cobalt dealer for correction.
- The filter may be plugged. Clean the filter, which is located at the tank, under the deck mid-berth.

Issue:

Low water pressure at the sink.

Consider:

- Most likely, either the fresh water pump is defective, or there is a restriction/obstruction in the water line. See an authorized Cobalt dealer for assistance.

Issue:

The head (where equipped) will not flush.

Consider:

- The head circuit breaker may have tripped or be in the OFF position. Correct the issue and reset so that the breaker is in the ON position.
- The line to the waste tank may be blocked. See an authorized Cobalt dealer for assistance.



Blower System

Issue:

The blower is not working.

Consider:

- **Never operate the boat without the blower system operating correctly!** Accumulating fumes that are not released through the blower system can result in an explosion or other serious accident that could result in death to those on-board. If the blower ceases to work properly while boating is underway, terminate the outing **IMMEDIATELY** and return to shore with the engine compartment covers open. If there is an odor of fuel or exhaust present, turn OFF the engine **IMMEDIATELY** and seek a tow to shore. See the *Safety* section of this manual; additional details are also available in other sections of this manual.

WARRANTY TRANSFER—BOAT

See the Warranty Statement previously detailed in this owner's manual. Read carefully to determine the appropriate circumstances under which existing and remaining warranty may be transferred to subsequent owners of the boat. In instances where warranty is transferable, complete this form and fax to (620) 325-2190, or mail to Cobalt Boats 1715 North 8th Street, Neodesha KS 66757.

Date: _____

Cobalt Boat Serial Number: _____

Original Owner (Seller): _____

Address: _____

Home Phone: (_____) _____ Work Phone: (_____) _____

Email Address: _____

New Owner (Purchaser): _____

Address: _____

Home Phone: (_____) _____ Work Phone: (_____) _____

Email Address: _____

Submitted by (Dealer): _____

Individual: _____



BOAT INFORMATION

Complete and store in a secure location other than the boat.

Owner _____

Home Port _____

Boat Name _____

Selling Dealer _____

Port Ignition Key Number _____ Starboard Ignition Key Number _____

Cabin Key Number _____

Registration Number _____ State _____

Hull Serial Number _____ Warranty Registration Date ____/____/____

Engine Make and Model Number _____

Engine Serial Number (where applicable) _____

Port Engine Serial Number _____ Stbd Engine Serial Number _____

Port Drive Serial Number _____ Stbd Engine Serial Number _____

Propeller Size _____

Generator Model Number _____

VHF Radio Make & Model Number _____ Serial No. _____

GPS Make & Model Number _____ Serial No. _____

Radar Make and Model Number _____ Serial No. _____

DVD Make and Model Number _____ Serial No. _____

Stereo Make and Model Number _____ Serial No. _____

TV, Cabin Make and Model Number _____ Serial No. _____

TV, Mid-berth Make and Model Number _____ Serial No. _____

Subwoofer Make and Model Number _____ Serial No. _____

FLOAT PLAN

Copy this page and fill out the copy before an outing. Leave the completed copy with a reliable person who can be depended on to notify the USCG or other rescue organization if you do not return as scheduled. Do not file this plan with the USCG.

Name _____

Telephone _____

Description of Boat: Type _____ Color _____ Trim _____

Registration Number _____ State _____

Length _____

Other Identifying Boat Info _____

Persons Aboard (Name, Age, Address & Phone)

Engine Type _____ Horsepower _____

No. of Engines _____ Fuel Capacity _____

Survival Equipment:

PFDs _____ Flares _____ Mirror _____

Smoke Signals _____ Flashlight _____ Food _____

Paddles _____ Water _____ Anchor _____

Raft/Dinghy _____ EPIRB _____

Radio: Yes _____ No _____ Type _____ Frequency _____

Destination _____ Estimated Time of Arrival _____

Expected to Return by _____

Auto/Tow Vehicle _____ License No. _____

Parked Location _____

If not returned by _____, contact the Coast Guard or call _____

Stereo Make and Model Number _____ Serial No. _____

(Local Authority), or Coast Guard Phone Number: _____

SERVICE LOG

Service Performed	Date	Date	Date	
Oil Change, Including Replace Oil Filter				
Wax Exterior				
Thoroughly Clean Interior				
Replace Battery				
Charge or Replace Fire Suppression Equipment				
Check/Repair PFDs and Other Safety Equipment				
Check/Repair Engine Mounts				
Check/Repair Steering System				
Check/Repair Shift & Throttle System				
Inspect/Repair/Replace Ballast Pumps				
Inspect/Repair/Replace Bilge Pumps				
Replace Fuel Filter/Inspect Fuel Lines				
Check Hull Paint (where applied)				
Prepare for Storage/Winterization				
Recommission Boat				
Other				
Other				
Other				
Other				
Other				

INDEX

100 Hours, Every	133
50 Hours, Every	133
A29 (Specifications)	46
A29 Helm.....	73
A29, R33 and R35 Battery Switch.....	69
AC Electrical	64
Accidents, Reporting.....	27
Addendum A—Service Assist Service Agreement.....	139
Additional Cleaning Advice.....	128
Additional Precautions for Towed Skier/Rider	38
Afloat, Staying.....	42
After Each Use (Care and Maintenance).....	133
Aids to Navigation.....	34
Air Compressor	96
Air Conditioning 12V DC Only.....	93
Air Conditioning/Heating.....	93
Alarm, Engine Alert.....	80
Alarms (Troubleshooting).....	144
Aluminum Arch with Sunshade, Stainless Steel.....	104
Aluminum Components, Stainless Steel, Chrome and	116
Amenities.....	7
Anchor Light.....	96
Anchor, Windlass	83
Anodes, Galvanic Corrosion and Zinc.....	118
Archs, Splash & Stow, Canvas and Covers	102
Assistance, Rendering.....	27
Automated Sureshade, Hardtop with.....	105
Automatic Charging Relay (ACR), All Models	69
Ballast and Plumbing (Troubleshooting), Bilge	144
Basic Function Features.....	81
Basic Rules of the Road.....	32
Basic Safety Rules	12
Battery Charger—Optional.....	69
Battery Connections	66
Battery Failure.....	143
Battery Switch, A29, R33 and R35.....	69
Battery Switches, R30.....	68
BBQ Range Top, Cockpit.....	94
Before Each Use (Care and Maintenance)	131
Before Operating	7
Before You Start	110
Bilge (Cleaning).....	129
Bilge Pump(s).....	21
Bilge, Ballast and Plumbing (Troubleshooting).....	144
Bimini Top with Easy Fold, Premium	103
Blower System (Troubleshooting).....	144
Boarding Ladder, Swim Platform and	84
Boarding	112
Boat Information.....	146
Boating Regulations	32
Boating Safety Education Opportunities.....	18
Boating Under the Influence.....	27
Bow Eye	83
Bow Filler Cushion, Removable	91
Bow Shade	106
Bow Tonneau Cover.....	102
Breaker Panel, Circuit.....	65
Breaker Switch, Shore Power Inlet	65
Break-in (Care and Maintenance).....	131
Burdened Vessel.....	32
Cabin Access Door	91
Cabin Distribution Panels	66
Cabin Filler Cushion, Removable	91
Cabinetry and Wood.....	125
California Air Resource Board (CARB) Labels.....	29
California Evaporative Emissions Control System Warranty Statement.....	140
Canvas (Cleaning)	123
Canvas and Covers, Arches, Splash & Stow	102
Canvas Components (Cleaning), Other	124
Capsizing	42
Captain's Chair Adjustments and Operation	90
Carbon Monoxide Detector	80
Carbon Monoxide Safety.....	23
Care and Cleaning of Fresco Chill Chil Cool Technology Vinyl.....	121
Care and Cleaning of Vinyl.....	120
Care and Maintenance	115
Care and Maintenance, Salt Water	116
Care, Leath	123
Care, On-Going	116
Cart.....	125
Certificate of Limited Warranty, Cobalt	138
Certifications.....	7
Certifications, Construction Standards.....	7
Charger—Optional, Battery	69
Check List—Before Leaving the Dock, Pre-operation	13
Chrome and Aluminum Components, Stainless Steel	116
Circuit Breaker Panel	65
Cleaning Advice, Additional.....	128
Cleaning the Deck and Hull.....	127
Cleaning, General.....	116
Cleats.....	83
Cobalt Certificate of Limited Warranty.....	138
Cockpit BBQ Range Top	94
Cockpit Dinette Table	95
Cockpit Heater.....	93
Cockpit Tonneau Cover.....	103
Collisions	42
Comfort and Enhancements.....	89
Communications, Radio.....	22
Compartments (Cleaning), Storage	124
Compartments, Storage	92
Compass	19
Components and Switches	75
Components and Systems	59
Components, Entertainment	95
Components, Stainless Steel, Chrome and Aluminum	116
Compressor, Air.....	96

Concerns, Environmental	28	EPA Fuel Tank.....	72
Condensation Cause and Protection	119	Equipment, Fire Suppression	62
Conditions, Hazardous	28	Equipment, Other Navigation	19
Connection, Shore Power.....	64	Equipment, Recommended Safety.....	22
Connections, Battery	66	Equipment, Safety and Required	19
Construction Standards/Certifications	7	Every 100 Hours	133
Construction, Features	7	Every 50 Hours	133
Controls, Wake Surf.....	87	Explosion and Fire	41
Cooler or Ice Chest.....	95	Explosion, Fire.....	111
Cooling System (Care and Maintenance), Engine/ Propulsion	134	Extinguisher Manual Pull, Fire.....	63
Corrosion and Zinc Anodes, Galvanic.....	118	Extinguisher, Fire	21
Corrosion Protection	117	Failure, Operation	43
CorrosionX.....	117	Fallen Skier or Rider	39
Cover, Bow Tonneau	102	Features, Basic Function.....	81
Cover, Cockpit Tonneau.....	103	Features/Construction.....	7
Covers, Arches, Splash & Stow, Canvas and	102	Fire Extinguisher Manual Pull.....	63
Cradle, Storage.....	135	Fire Extinguisher	21
Craft Design Category	6	Fire Port	63
Crossing.....	33	Fire Suppression Equipment.....	62
Cruise Control	87	Fire, Explosion and.....	41
Cup Holders	92	Fire/Explosion.....	111
Current Reality (Vinyl).....	120	Flip Down, Swim Step.....	86
Dark Stowage Area.....	122	Float Plan.....	147
DC Electrical.....	63	Flooding, Swamping and.....	42
Deck and Hull Finishes.....	127	Floor Covering, Sea Grass	125
Deck and Hull, Cleaning the.....	127	Flotation Devices, Personal.....	20
Detector, Carbon Monoxide	80	Focus on Prevention (Mold & Mildew)	119
Develop WATER SENSE	39	Freezer, Refrigerator.....	94
Devices, Personal Flotation.....	20	Fresco Chill Chil Cool Technology Vinyl, Care and Cleaning..	121
Dinette Table, Cockpit	95	Fresh Water System	72
Disposal with Optional Macerator, Waste	101	Fresh Water	98
Disposal, Dockside Waste	100	Fuel Requirements.....	70
Distress Signals, Visual	21	Fuel System (Care and Maintenance)	134
Distribution Panels, Cabin	66	Fuel System.....	70
Dockside Pump-Out	100	Fuel Tank, EPA.....	72
Dockside Waste Disposal	100	Fueling	70
Door, Cabin Access	91	Fuses.....	66
Drowning.....	43	Galvanic Corrosion and Zinc Anodes.....	118
Easy Fold, Premium Bimini Top with	103	Gauges, Switches and Video Screens (Troubleshooting)	143
Education Opportunities, Boating Safety.....	18	General Boating Safety Topics	23
Education, Owner Responsibility and Boating	16	General Cleaning.....	116
Electrical System (Care and Maintenance).....	134	General Prudential Rule	33
Electrical System (Troubleshooting).....	143	Generator—Optional	69
Electrical System.....	63	Getting Underway	109, 112
Electrical, AC	64	Glove Box	91
Electrical, DC.....	63	Grounding	42
Electrically Operated Head	100	Guidelines, Tow Line	39
Embracing Safety	12	Hand Signals	36
Emergency Procedures	41	Handling Dock and Mooring Lines	113
Emergency Safety Stop Switch	19	Hardtop with Automated Sureshade.....	105
Emergency, Medical	43	Hazardous Conditions	28
Encountering Another Vessel.....	32	Head Shower and Sink/Transom Shower Washdown	99
Engine Alert Alarm.....	80	Head	99
Engine/Propulsion/Cooling System (Care and Maintenance) ..	134	Head, Electrically Operated	100
Enhancements, Comfort and.....	89	Head-On, Meeting	33
Entertainment Components	95	Heater, Cockpit	93
Environmental Concerns	28	Heating, Air Conditioning.....	93

Helm and Instrumentation	73	Minors and Licensing, Operation by	18
Helm Seat Electric Slide Operation.....	91	Misuse, Product	27
Helm, A29.....	73	Mold & Mildew Cause and Prevention	118
Helm, R30.....	73	Monthly (Care and Maintenance).....	133
Helm, R33.....	74	Motor Box Assembly.....	88
Helm, R35.....	74		
Horn or Whistle.....	21	Nautical Terms.....	8
Hot Water Tank.....	98	Navigation Equipment, Other	19
Hull Finishes, Deck and.....	127	Navigation Lights	19
Hull, Cleaning the Deck and.....	127	Navigation, Aids to.....	34
Hydraulic Swim Platform.....	85	Night Running	35
		NMMA	7
Ice Chest, Cooler or.....	95		
If the Boat is Sold.....	7	On and Under the Water	84
Important Safety Information.....	17	On the Water	112
Index	150	On-Going Care	116
Inflatable Accessory Care	124	On-Product Warning Labels.....	30
Information, Boat	146	Operating Information	110
Information, Operating	110	Operating, Before	7
Inlet Breaker Switch, Shore Power	65	Operation by Minors and Licensing.....	18
Instrumentation, Helm and	73	Operation Failure	43
Insurance	18	Operation, Prior	12
Interior/Exterior Care and Maintenance.....	116	Other Canvas Components (Cleaning).....	124
Introduction	6	Other Navigation Equipment	19
		Other Rules of the Road	33
Jump-Start Studs.....	67	Overboard, Person	42
		Overtaking.....	33
Labels, On-Product Warning.....	30	Owner and Operators, Responsibilities of Boat	17
Ladder, Swim Platform and Boarding	84	Owner Responsibility and Boating Education	16
Launching.....	112	Owner Responsibility/Warranty Procedure	7
Leather Care	123		
Licensing, Operation by Minors and	18	Panel, Circuit Breaker	65
Life Raft.....	23	Panels, Cabin Distribution	66
Lifting Slings, Using	135	Passenger Safety.....	23
Lifting the Boat	135	Performance Boosts	87
Light, Anchor.....	96	Person Overboard	42
Lighting Operation, RGB	97	Personal Flotation Devices.....	20
Lights, Navigation	19	Plan, Float.....	147
Lights, Underwater.....	97	Platform (Non-Teak), Swim.....	129
Limited Warranty, Cobalt Certificate of.....	138	Platform and Boarding Ladder, Swim	84
Lines, Handling Dock and Mooring	113	Platform Dragging (“Teak Surfing”).....	40
Loading	112	Platform, Hydraulic Swim.....	85
Loading, Proper	25	Platform, Teak Swim.....	128
Locations, Serial Number	8	Plumbing (Troubleshooting), Bilge, Ballast and.....	144
Locations, Warning Labels and	30	Pooling Water.....	120
Log, Service.....	148	Port, Fire	63
Logs and Index, Troubleshooting.....	141	Precautions for Towed Skier/Rider, Additional.....	38
		Precautions While Underway.....	13
Macerator Pump.....	101	Precautions.....	110
Macerator, Waste Disposal with Optional	101	Premium Bimini Top with Easy Fold	103
Maintenance and Service, Scheduled	130	Pre-operation Check List—Before Leaving the Dock	13
Maintenance, Care and.....	115	Prior to Operation.....	12
Maintenance, Salt Water Care and.....	116	Privileged Vessel	32
Manual Pull, Fire Extinguisher.....	63	Product Misuse.....	27
Marine Growth (Cleaning)	129	Proper Loading	25
Marine Toilet (Head)	99	Proposition 65.....	29
Medical Emergency.....	43	Propulsion System	112
Meeting Head-On	33	Propulsion/Cooling System (Care and Maintenance), Engine .	134
MerCruiser	7	Protection, Corrosion	117
Microwave.....	94	Publications.....	8

Pump(s), Bilge.....	21	Safety, Passenger	23
Pump, Macerator	101	Safety, Watersports	36
Pump-Out, Dockside.....	100	Salt Water Care and Maintenance	116
		Sauce, Vinyl.....	121
Quarterly (Care and Maintenance).....	133	Scheduled Maintenance and Service	130
		Sea Grass Floor Covering.....	125
R30 (Specifications).....	48	Seakeeper.....	89
R30 Battery Switches.....	68	Seating.....	89
R30 Helm.....	73	Serial Number Locations.....	8
R33 (Specifications).....	50	Service Assist Service Agreement, Addendum A	139
R33 and R35 Battery Switch, A29.....	69	Service Log	148
R33 Helm.....	74	Service, Scheduled Maintenance and	130
R33 Outboard (Specifications).....	52	Services Requirements, Warranty	7
R35 (Specifications).....	54	Shade, Bow	106
R35 Battery Switch, A29, R33 and.....	69	Shore Power Connection.....	64
R35 Helm.....	74	Shore Power Inlet Breaker Switch	65
R35 Outboard (Specifications).....	56	Shower and Sink/Transom Shower Washdown, Head	99
		Signal Words and Symbols Used in this Manual.....	12
Radio Communications.....	22	Signals, Hand	36
Raft, Life.....	23	Signals, Visual Distress	21
Range Top, Cockpit, BBQ.....	94	Sink/Transom Shower Washdown, Head Shower and	99
Reactivating the Boat After Storage	136	Ski Tow Pylon, Removable.....	81
Reboarding Methods.....	84	Skier or Ride, Fallen	39
Reboarding, Unassisted Means of	43	Slings, Using Lifting	135
Recommended Safety Equipment.....	22	Soft Track Mat and Swim Platform Mat Care and Maintenance.....	128
Recommended Spare Equipment.....	23	Sold, If the Boat is.....	7
Refrigerator/Freezer	94	Solutions (Vinyl).....	120
Registration	18	Spare Equipment, Recommended.....	23
Regulations, Boating.....	32	Specifications.....	45
Removable Ski Tow Pylon.....	81	Splash & Stow.....	106
Rendering Assistance.....	27	Splash & Stow, Canvas and Covers, Arches	102
Reporting Accidents.....	27	Spot and Stain Removal.....	122
Required Equipment, Safety and.....	19	Stainless Steel, Chrome and Aluminum Components	116
Requirements, Fuel.....	70	Stainless Steel/Aluminum Arch with Sunshade	104
Requirements, Warranty Services	7	Standards/Certifications, Construction	7
Responsibilities of Boat Owner and Operators	17	Stationary Arch with Awlgrip Topcoat (Cleaning).....	129
Responsibilities, Safety and	11	Staying Afloat.....	42
Responsibilities, Towed Person Safety	37	Steering System Maintenance Schedule	130
Responsibility and Boating Education, Owner	16	Step—Flip Down, Swim.....	86
Responsibility/Warranty Procedure, Owner	7	Stereo, Television	96
RGB Lighting Operation	97	Storage and Winterization.....	135
Routing	60	Storage Compartments (Cleaning)	124
Rule, General Prudential	33	Storage Compartments	92
Rules of the Road, Basic.....	32	Storage Cradle.....	135
Rules of the Road, Other	33	Storage, Reactivating the Boat After	136
Rules, Basic Safety	12	Storage/Winterization General Information	136
Running, Night	35	Stowage Area, Dark.....	122
		Studs, Jump-Start.....	67
Safe Speed.....	23	Sunshade, Stainless Steel/Aluminum Arch with	104
Safety and Required Equipment.....	19	Suppression Equipment, Fire.....	62
Safety and Responsibilities	11	Sureshade, Hardtop with Automated.....	105
Safety Education Opportunities, Boating.....	18	Swamping and Flooding.....	42
Safety Equipment, Recommended	22	Swim Platform (Non-Teak).....	129
Safety Information, Important.....	17	Swim Platform and Boarding Ladder.....	84
Safety Responsibilities, Towed Person	37	Swim Platform Mat Care and Maintenance, Soft Track Mat and.....	128
Safety Rules, Basic	12	Swim Platform, Hydraulic.....	85
Safety Stop Switch, Emergency.....	19	Swim Platform, Teak.....	128
Safety Topics, General Boating	23	Swim Step—Flip Down.....	86
Safety While Maintaining the Vessel.....	15		
Safety, Embracing	12		

Switch, A29, R33 and R35 Battery.....	69	VacuFlush Toilet System.....	99
Switch, Emergency Safety Stop.....	19	Vessel, Burdened.....	32
Switch, Shore Power Inlet Breaker	65	Vessel, Encountering Another	32
Switch, Transom Tilt.....	89	Vessel, Privileged	32
Switches and Video Screens (Troubleshooting), Gauges	143	Video Screens (Troubleshooting), Gauges, Switches and	143
Switches, Components and	75	Vinyl Interior and Upholstery	118
Switches, R30 Battery.....	68	Vinyl Sauce	121
Symbols Used in this Manual, Signal Words and.....	12	Vinyl, Care and Cleaning	120
Symbols.....	10	Visual Distress Signals	21
System, Electrical	63	Volvo Penta Ocean Series Outdrive	86
System, Fresh Water	72	Volvo Penta.....	7
System, Fuel.....	70		
System, Propulsion.....	112	Wake Surf Controls	87
Systems, Components and	59	Warning Labels, On-Product.....	30
		Warranty Procedure, Owner Responsibility	7
Table of Contents.....	5	Warranty Services Requirements	7
Table, Cockpit Dinette	95	Warranty Statement	137
Tank, EPA Fuel.....	72	Warranty Statement, California Evaporative Emissions Control.....	140
Tank, Hot Water.....	98	Warranty Transfer—Boat	145
Teak Surfing, Platform Dragging.....	40	Warranty, Cobalt Certificate of Limited	138
Teak Swim Platform	128	Waste Disposal with Optional Macerator	101
Television/Stereo.....	96	Waste Disposal, Dockside	100
Terms, Nautical.....	8	WATER SENSE, Develop	39
Tie-Down Locations	81	Water System (Care and Maintenance)	134
Toilet (Head), Marine	99	Water Tank, Hot.....	98
Toilet System, VacuFlush.....	99	Water, Fresh Water	72
Tonneau Cover, Bow	102	Water, Fresh.....	98
Tonneau Cover, Cockpit.....	103	Watersports Safety	36
Tool Kit	89	Weighting Your Boat During Watersport Activities 25	
Tow Line Guidelines	39	Whistle, Horn or.....	21
Towed Person Safety Responsibilities	37	Windlass/Achor	83
Towed Skier/Rider, Additional Precautions for	38	Windshield (Cleaning)	129
Towing	43	Windshield	92
Transom Tilt Switch	89	Winterization General Information, Storage.....	136
Treatment (Mold & Mildew)	119	Winterization, Storage and.....	135
Troubleshooting.....	142	Wood, Cabinetry and.....	125
Troubleshooting, Logs and Index.....	141	Words and Symbols Used in this Manual, Signal.....	12
Unassisted Means of Reboarding	43	Zinc Anodes, Galvanic Corrosion and.....	118
Under the Influence, Boating.....	27		
Under the Water, On and	84		
Underwater Lights.....	97		
Underway, Precautions While	13		
Unscheduled Maintenance.....	134		
Upholstery, Vinyl Interior and	118		
Use (Care and Maintenance), After Each.....	133		
Use (Care and Maintenance), Before Each	131		
Using Lifting Slings	135		