



# Introduction



Your Cobalt boat has been designed and constructed to meet or exceed all U.S. Coast Guard and National Marine Manufacturers Association requirements in effect at the time of production. As the boat owner, you retain responsibility for ensuring the boat is operated correctly, safely, and that it is properly maintained, not only to retain its value but to ensure the safety of those onboard and other boaters in the vicinity.

This owner's manual is designed to help you maximize the enjoyment of your Cobalt boat, and to acquaint you with proper operation, care, stor-

age and maintenance of your investment. Prior to operating the boat for the first time, you **MUST** read the entire manual and familiarize yourself with the safety labels adhered to the boat. Because of the important safety and maintenance information, you should include the manual with the boat if and when it is sold to a future owner or as a trade-in. Owners should also review any and all material supplied or available online from component manufacturers.

Even if you're a seasoned boater and have previously owned a Cobalt boat, note that the information in the manual was specifically developed for this boat and may



be different from any prior Cobalt you may have owned. As you read this manual, please remember that “common sense” and “courtesy” are the most valuable traits you can employ to fully enjoy safe boating. It is also to your personal advantage to become well-acquainted with the rules and regulations of boating. Cobalt cannot anticipate every potential situation that can arise with regard to boating safety or maintenance. By following the information provided, along with common sense and good judgment, owners and operators can reduce risk to all who participate.

Cobalt is also committed to continuous innovation. The

company reserves the right to introduce new product or changes to existing model lines at any time without notification or incurring responsibility to make the same changes to boats in the market and completed prior to the date of change.

Updates to this information will be posted online as they occur. For service and assistance, contact your authorized Cobalt dealer. The dealership staff will be happy to answer questions you may have about your Cobalt boat.

**Your Cobalt Team**

# WELCOME



# TABLE OF CONTENTS

<b>Introduction.....</b>	<b>6</b>	<b>Care and Maintenance.....</b>	<b>101</b>
Owner Responsibility/Warranty Procedures.....	7	Interior/Exterior Care and Maintenance.....	102
Certifications .....	7	On-Going Care .....	102
Features/Construction.....	7	Corrosion Protection .....	103
Publications .....	8	Vinyl Interior and Upholstery .....	104
Nautical Terms .....	8	Scheduled Maintenance and Service.....	113
Symbols .....	10	Storage/Winterization.....	118
<b>Safety and Responsibilities .....</b>	<b>11</b>	<b>Warranty Statements .....</b>	<b>121</b>
Embracing Safety .....	12	Cobalt Certificate of Limited Warranty.....	122
Owner Responsibility and Boating Education .....	16	Addendum A—Service Assist Service Agreement.....	123
Safety and Required Equipment .....	19	California Evaporative Emissions Control System Warranty Statement.....	124
General Boating Safety Topics .....	23	Monsoon Engines Limited Warranty Statement.....	125
On-Product Warning Labels.....	30	Malibu Trailers Limited Warranty Statement.....	130
Basic Rules of the Road .....	32	<b>Engine Option.....</b>	<b>137</b>
Watersports Safety .....	36	Monsoon Engines for Cobalt Boats.....	138
Emergency Procedures.....	41	Safety .....	138
<b>Specifications .....</b>	<b>45</b>	General Information.....	139
R4.....	46	California Emissions Information .....	143
R4 Outboard .....	48	Monsoon Engine Support Systems.....	143
R6.....	50	Break-In Period.....	148
R6 Outboard .....	52	Care and Maintenance .....	149
R8.....	54	Winterizing the Engine .....	152
R8 Outboard .....	56	Monsoon Engine Maintenance Schedule.....	153
<b>Components and Systems .....</b>	<b>59</b>	Recommended Mercury Marine Outdrive Maintenance Schedule.....	153
Introduction .....	60	<b>Trailer Option.....</b>	<b>155</b>
Routing.....	60	Cobalt Trailers.....	156
Fire Suppression Equipment.....	64	Connection to the Tow Vehicle .....	157
Electrical System.....	65	How to Connect to the Tow Vehicle .....	158
Fuel System .....	67	Connecting to the Boat.....	160
Freshwater System.....	69	Trailer Components and How They Function .....	161
Helm and Instrumentation .....	70	Towing Advice .....	169
Basic Function Features .....	74	Launching and Reloading the Boat from the Trailer .....	170
On and Under the Water .....	76	<b>Troubleshooting, Logs and Index.....</b>	<b>171</b>
Performance Boosts .....	78	Troubleshooting.....	172
Comfort and Enhancements .....	82	Warranty Transfer—Boat .....	175
Canvas and Covers.....	90	Warranty Transfer—Engine and/or Trailer.....	175
<b>Getting Underway .....</b>	<b>95</b>	Boat Information .....	176
Operating Information .....	96	Float Plan.....	177
Precautions.....	96	Service Log.....	178
Launching.....	98	Index.....	180
Getting Underway.....	98		

# INTRODUCTION

This owner's manual contains information that is necessary to run the boat properly, as well as safety topics, operation and maintenance requirements.

Even if everything has been planned and designed for the safety of the boat and its users, boating is highly dependent on the weather conditions, the state of the boating water, and the experience and physical condition of the crew. Because of multiple factors, it is impossible to guarantee absolute safety. It is your responsibility as the owner or user to know the boat's equipment, its capabilities, and the boat's intended use.

The specific information on the operation of the equipment and systems with which the boat is supplied or fitted should be supplied by that manufacturer. Read, understand and keep all the information supplied in a clean, as dry as possible, location for ready access and referral as needed. Familiarize yourself and all users with the boat's components before putting the boat into use.

All persons should wear a suitable life preserver/personal flotation device when onboard. In some countries, states, or locales, it is a legal requirement to wear a suitable life preserver/personal flotation device at all times that complies with the regulations and laws.

## WARNING

**Children, disabled people and non-swimmers should wear a personal flotation device at all times. Children and non-swimmers need special instruction in the use of life preservers/personal flotation devices. Inform all passengers on the proper use of these devices and of the location of all safety equipment, man-overboard recovery equipment, and the location and deployment of any ladder.**

## WARNING

**Avoid contact with any running machinery or moving parts, such as an engine, generator or propeller. Contact can result in, but is not limited to, loss of body parts, strangulation, burns and/or severe loss of blood. Keep all machinery guards in place when machinery is in operation.**



## Craft Design Category

*(Note: Significant Wave Height is the mean height of the highest one-third of the waves, which approximately corresponds to the wave height estimated by an experienced observer. Some waves can be double or more than this height.)*

### OCEAN—Category A

Craft designed to operate in winds that may exceed

wind Beaufort force 8 and in significant wave heights of 13'1.44" (4 meters) and above, and is largely self-sufficient. Abnormal conditions such as hurricanes are excluded. Such conditions may be encountered on extended voyages—for example, across oceans, or inshore when unsheltered from the wind and waves for several hundred nautical miles.

### OFFSHORE—Category B

Craft designed to operate in winds up to Beaufort force 8 and associated wave heights and in significant wave heights of 13'1.44" (4 meters). Such conditions may be encountered on offshore voyages of sufficient length, or on coastal waters when unsheltered from the wind and waves for several dozen nautical miles. These conditions may also be experienced on inland seas of sufficient size for the wave height to be generated.

### INSHORE—Category C

Craft designed to operate in winds up to Beaufort force 6 and associated wave heights and significant wave heights up to 6'6.7" (2 meters). Such conditions may be encountered in exposed inland waters, in estuaries and in coastal waters in moderate weather conditions.

### SHELTERED WATERS—Category D

Craft designed to operate in winds up to Beaufort force 4 and associated wave heights (occasional maximum waves of 1'7.7" [0.5 meters] height). Such conditions may be encountered in sheltered inland waters, and in coastal waters in fine weather.



# OWNER RESPONSIBILITY/WARRANTY PROCEDURE

## Before Operating

Before operating a Cobalt boat for the first time, it is necessary for all potential operators to read and understand this manual. Also, read all other component manuals and information supplied in the owner's packet.



## Warranty Services Requirements

All Cobalt warranty service must be completed by an authorized Cobalt dealer. If the boat cannot be returned to the selling dealership, contact the selling dealership for assistance in coordinating the warranty repairs. Any

claims concerning a Cobalt Boat without prior approval from Cobalt Boats for repairs completed by an unauthorized dealership, repair service, or individual may be denied.



## If the Boat is Sold

The warranties may be transferable. If the boat is sold to anyone other than an authorized Cobalt dealer, refer to the Warranty Transfer Form near the end of this manual. If the proper transfer procedures are not followed, future warranty claims may be denied.

# CERTIFICATIONS

## NMMA

Cobalt Boats is a member of the National Marine Manufacturers Association (NMMA). This independent organization's members include boat, engine and marine equipment manufacturers focused on the improvement and safety of boating.

Cobalt Boats are NMMA-certified. An NMMA certification not only satisfies the U.S. Coast Guard (USCG) regulations but also the more rigorous equipment and system standards based on those established by the American Boat and Yacht Council, Inc. (ABYC). Cobalt boats meet or exceed NMMA safety-based certifications.

Cobalt Boats has made a significant contribution to the boating industry by successfully completing the Mercury MerCruiser® propulsion-installation quality certification program and the Volvo Penta Certified OEM Program.

## MerCruiser

The MerCruiser Program partners boat builders with MerCruiser to improve product quality and enhance boating enthusiast satisfaction. The certification program is designed to review all facets of manufacturing and installation processes and to identify opportunities to implement Lean Six Sigma processes and training programs. Key areas of focus include assembly and component specifications, propulsion-installation processes and industry-standard end-of-line test procedures.



## Volvo Penta

The Volvo Penta Program requires the boat builder commitment to follow the established training requirements, installation procedures and documentation processes throughout the engine installation and testing process. Ultimately, the goal of the program is to improve integrated product quality and customer satisfaction, as well as to reduce warranty repairs and costs.

# FEATURES/CONSTRUCTION

## Amenities

Cobalt boats incorporate classic styling with the clean lines that have defined Cobalt design for over 40 years. Performance features include hand-laid, reinforced Kevlar with an all-fiberglass stringer system and AME 1000 vinylester resins used on the deck and hull for superior strength, toughness and weight savings.

## Construction Standards/Certifications

A Limited Warranty Statement explaining terms and conditions appears elsewhere in this owner's manual. Familiarize yourself with the contents, requirements and limitations as described in the Statement. Failure to follow the operating instructions and proper maintenance requirements as outlined within this owner's manual may void the warranty.

Construction standards detailing industry standards followed in building Cobalt Boats are explained within this manual. Contact an authorized Cobalt dealer for any additional information regarding construction information.



## Serial Number Locations

All Cobalt boats, the engine and propulsion units, and various other components onboard are marked with unique serial numbers. It is good practice to prepare a

list of all serial numbers and store the list securely away from the boat. A page is supplied at the end of this owner's manual for that purpose.

The Hull Identification Number (HIN) is located on the upper starboard side of the transom. For the locations of other serial numbers, refer to the equipment operator's manuals supplied in the owner's packet.

## PUBLICATIONS

The owner's packet includes information about onboard systems and equipment furnished by suppliers whose components are used on Cobalt boats. Refer to

these manufacturer's manuals for additional operation and maintenance instructions not covered in this owner's manual.

## NAUTICAL TERMS

The following terminology is provided to assist boats in understanding marine lingo:

**ABOARD**—On or in the boat.  
**ABYC**—American Boat and Yacht Council, Inc.  
**AFLOAT**—On the water.  
**AFT**—Toward the rear or stern of the boat.  
**AGROUND**—Touching bottom.  
**AMIDSHIP**—Center or middle of the boat.  
**ANCHOR**—(1) A casting shaped to grip the lake bottom to hold the boat in place. (2) The act of setting the anchor.  
**ASHORE**—On the shore.  
**ASTERN**—Toward the stern or back of the boat.  
**BAIL**—To remove water from the boat with a pump, bucket, sponge or other aid.  
**BEAM**—The widest measurement of the boat.  
**BEARING**—Relative position or direction of an object from the boat.  
**BILGE**—The lowest interior section of the boat hull.  
**BOARDING**—To enter the boat.  
**BOUNDARY WATERS**—A body of water between two areas of jurisdiction: i.e., a river between two states.  
**BOW**—The front of the boat.  
**BULKHEAD**—Vertical partition (wall) in a boat.  
**BUNKS**—Carpeted trail hull supports.  
**BURDENED BOAT**—Term for the boat that must “give-way” to boats in right-of-way.  
**CAPACITY PLATE**—A plate that provides maximum weight capacity and engine horsepower rating information. It is located in full view of the helm.  
**CAPSIZE**—To turn over.  
**CAST-OFF**—To unfasten mooring lines in preparation for

departure.

**CENTER LINE**—A lengthwise imaginary line which runs fore and aft of the boat's keel.

**CHINE**—The point on a boat where the side intersects (meets) the bottom.

**CLEAT**—A deck fitting with ears to which lines are fastened.

**CONSOLE**—Also called the helm. The steering wheel area of the boat.

**CRANKING BATTERY**—The main battery used for engine starting and electrical circuits.

**CURRENT**—Water moving in a horizontal direction.

**DECK**—The horizontal structure that forms the “roof” of the hull, strengthening it and serving as the primary working surface.

**DEEP CYCLE BATTERIES**—Special long-running batteries which can be repeatedly discharged and recharged without significant loss of power.

**DOLLY WHEEL**—A rolling jack assembly at the front of the towing trailer used for positioning the coupler during trailer hookup.

**DRAFT**—the depth of the boat below the water line, measured vertically to the lowest part of the hull.

**ELECTROLYSIS**—The break-up of metals due to the effects of galvanic corrosion.

**EPIRB**—Emergency Position Indicating Radio Beacon.

**FATHOM**—Unit of depth or measure; 1 fathom equals 6 feet.

**FENDERS**—Objects placed alongside the boat for cushioning and protection of the boat's finishes. Sometimes called bumpers.



**FORE**—Toward the front or bow of the boat. Opposite of aft.

**FREEBOARD**—The distance from the water to the gunwale.

**FUEL SENDING UNIT**—The electrical device that is mounted to the fuel tank and controls the dashboard fuel gauge.

**GIVE-WAY BOAT**—(1) Term for the boat that must take whatever action necessary to keep well clear of the boat with the right-of-way in meeting or crossing situations. (2) The burdened boat.

**GUNWALE**—The rail or upper edge of a boat's side.

**HEAD**—A marine toilet.

**HELM**—The steering wheel or command area.

**HULL**—The body of the boat.

**HYPOTHERMIA**—A physical condition where the body loses heat faster than it can produce it.

**IN-LINE FUSE**—A type of protective fuse located in the power wire of a direct current (DC) circuit, usually near the battery.

**KEEL**—The lowest portion of the boat; extends fore and aft along the boat's bottom.

**LIST**—Leaning or tilt of a boat toward the side.

**LOA**—Length overall.

**MAKING WAY**—Making progress through the water.

**MARINE CHART**—Seagoing maps showing depths, buoys, navigation aids, etc.

**MOORING**—An anchor, chair, or similar device that holds a boat in one location.

**NAVIGATION AID**—Recognizable objects on land or sea such as buoys, towers or lights which are used to fix position to identify safe and unsafe waters.

**NMMA**—National Marine Manufacturers Association.

**NO-WAKE SPEED**—The speed at which a boat travels to produce an imperceptible wake.

**PFD**—Personal flotation device.

**PITOT TUBE**—See *SPEEDOMETER PICKUP TUBE*.

**PLANING HULL**—A hull designed to lift, thereby reducing friction and increasing efficiency.

**PORPOISE**—A condition in which the bow bounces up

and down, caused by trimming the engine too far out.

**PORT**—(1) The left side of a boat when facing the bow. (2) a destination or harbor.

**PRIVILEGED BOAT**—Term used for the boat with the right-of-way.

**RIGHT-OF-WAY**—Term for the boat that has priority in meeting or crossing situations. The stand on or privileged boat.

**RULES OF THE ROAD**—Regulations for preventing collisions on the water.

**SPEEDOMETER PICKUP TUBE**—Also called the pitot tube. The plastic device that extends below the bottom of the boat. It connects to the speedometer with flexible plastic tubing.

**STAND-ON BOAT**—Term for the boat that must maintain course and speed in meeting or cross situations. The privileged boat.

**STARBOARD**—The right side of the boat when looking toward the bow.

**STERN**—The back of the boat.

**STOW**—To pack the cargo.

**SURGE BRAKES**—A type of trailer braking system designed to automatically actuate when the tow vehicle's brakes are applied.

**TRANSDUCER**—The unit that send/receives signals for the depth sounder.

**TRANSOM**—The transverse beam across the stern.

**TRIM**—Fore to aft and side to side balance on the boat when loaded.

**UNDERWAY**—Boat in motion, i.e., not moored or anchored.

**USCG**—United States Coast Guard.

**VISUAL DISTRESS SIGNAL**—A device used to signal the need for assistance such as flags, lights and flares.

**WAKE**—The waves that a boat leaves behind when moving through the water.

**WATERWAY**—A navigable body of water.

**WINDLASS**—An electric winch to raise the anchor.

# SYMBOLS

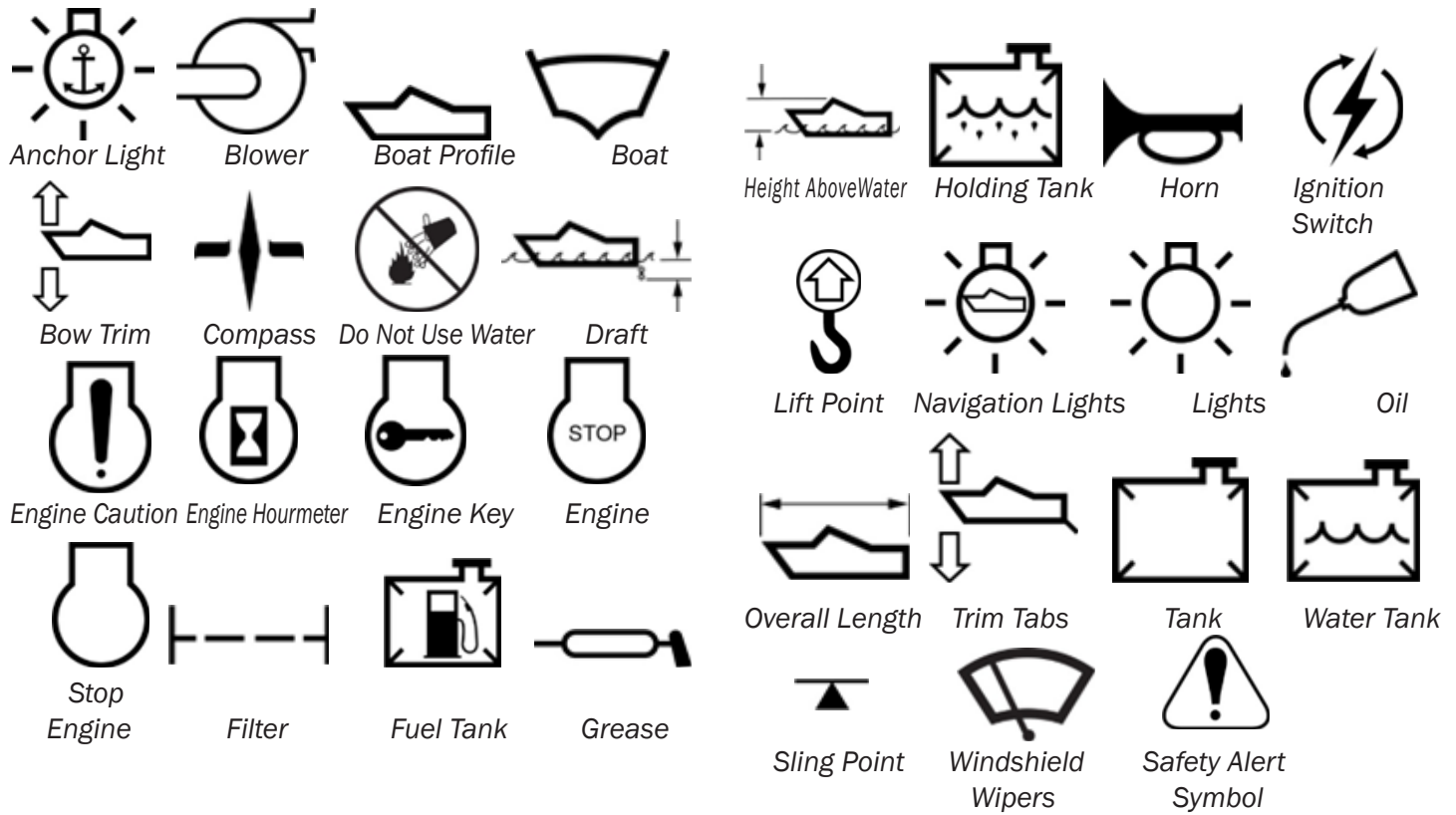

# Safety and Responsibilities

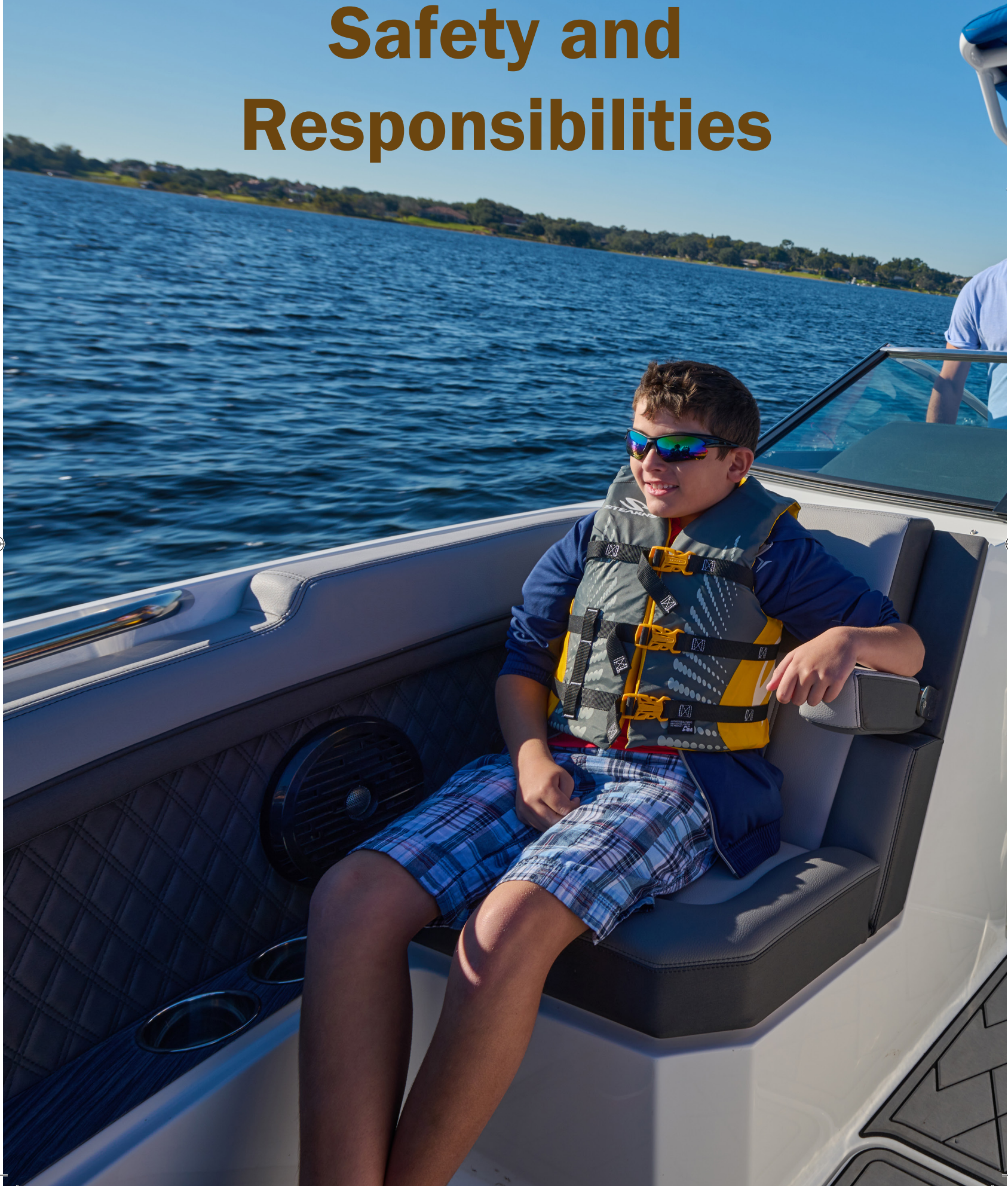

# EMBRACING SAFETY

Your safety, the safety of your passengers, and other boaters are among your responsibilities as operator of the boat. The boat must be in compliance with U.S. Coast Guard (USCG) safety equipment regulations. It is important for all boat operators including those who do not own the boat, to know how to react correctly to adverse weather conditions, have good navigation skills, and follow the “Rules of the Road” as defined by the USCG, as well as state, county, and local regulations.



## Prior to Operation

At the time of delivery, the owner/operator is responsible for:

- Understanding warranty terms and conditions of both the propulsion unit(s) and boat.
- Obtaining insurance.
- Examining the boat to ensure proper operation of all systems.

Before operating the boat, the owner/ operator is responsible for:

- Obtaining state registration of the boat.
- Providing the proper USCG-required safety equipment.
- Following the proper break-in procedure for the propulsion unit(s).
- Understanding the safety information and proper operating procedures as presented within this owner’s manual.

While operating the boat, the owner/operator is responsible for:

- Knowing that all safety equipment and personal flotation devices are in good condition and suitable for your boat and passenger load.
- Having at least one other passenger who is capable of handling the boat in an emergency.
- Following safe operating practices and the nautical Rules of the Road.
- Understanding proper maintenance and knowledge of the boat’s operating systems.
- Providing safety training for the passengers.
- Avoiding use of alcohol and other drugs.
- Providing assistance to other boaters.

More information on all of these topics follows.



## Signal Words and Symbols Used in this Manual

Throughout this manual specific precautions and symbols identify safety-related information. You will find **DANGER**, **CAUTION**, **WARNING**, and **NOTICE** symbols which require special attention. Please read them carefully and follow these precautions as indicated! They will explain how to avoid hazards that may endanger you, your passengers, towed participants, and other boaters. **PLEASE REVIEW ALL SAFETY INFORMATION.**



**DANGER** indicates a hazardous situation which, if not avoided, will result in death or serious injury.



**WARNING** indicates a hazardous situation which, if not avoided, could result in death or serious injury.



**CAUTION** indicates a hazardous situation which, if not avoided, could result in minor or moderate injury.



**NOTICE** is used to address practices not related to physical injury.



## Basic Safety Rules

**Make sure you understand all of the operating instructions prior to attempting to operate this boat.**

Boating-related accidents are generally caused by the operator’s failure to follow basic safety rules or written precautions. Most accidents can be avoided if the operator is completely familiar with the boat and its operation, follows recommended practices, and is able to recognize and avoid potentially hazardous situations.

*Past accident data shows that most **fatalities** involve actions which cause falls or ejections overboard, mishaps with towed persons, propeller strikes, collisions, and carbon monoxide exposure. Past accident data shows that most **injuries** are associated with collisions, mishaps with towed persons, falls or ejections overboard, being struck by the propeller, and fires and explosions. These incidents are mostly caused by operator inattention, operator inexperience, reckless operation, alcohol/drug use, excessive speed, passenger or towed person behavior, and violation of navigation rules.*



**Failure to observe the safety recommendations contained in this manual may result in severe personal injury or death to you or to others.** Use caution and common sense when operating your boat. Don't take unnecessary chances! Basic safety rules are outlined in this section of the manual.



## Pre-operation Check List— Before Leaving the Dock



**Failure to follow these precautions may result in severe injury or death to you and/or others.**

*The operator shall:*

- Check that weather conditions are safe for boating. It is the driver's responsibility to determine if weather or other factors have created an unsafe boating environment. Boaters must continuously be aware of weather conditions. Sudden storms, wind, water conditions, lightning, etc., can unexpectedly put boaters in grave danger. Always check the local weather report before going boating.
- Check that drain plugs are securely in place.
- Check bilge pump, horn, lights, blower and other equipment to verify they are operating properly.
- Verify that the emergency cutoff switch lanyard is in proper operating condition and is properly affixed to the driver.
- Check the operation of the steering system. Verify that the steering is operational before launching the boat. If the boat is already in the water, verify proper steering wheel operation at low speed. Turn the steering wheel full stop in both directions and verify proper rudder movement. Ensure that there is no binding or stiffness in the steering wheel rotation. Binding and stiffness are an indication that the steering needs repair. Failure of the steering cable will result in loss of control of the boat.
- Ensure that the load of persons, ballast, and equipment is within the limits stated on the USCG Maximum Capacities Plate and all are properly distributed, based on instructions in this manual.
- Check that all safety equipment and life jackets, personal flotation devices (PFDs), and throwable cushions are in good condition and suitable for your boat and passenger load.
- Inform all passengers where safety equipment is located and how to use it.
- Have at least one other passenger who is capable of operating the boat safely in case of an emergency.



**GASOLINE VAPORS CAN EXPLODE. BEFORE STARTING ENGINE, OPERATE THE BLOWER FOR FOUR (4) MINUTES, AND CHECK THE ENGINE COMPARTMENT BILGE FOR GASOLINE VAPORS.**

- It is very important to open the engine cover, where equipped, and check the engine compartment and bilge for liquid gasoline and gasoline vapors prior to each use of your boat and after refueling. Failure to do so may result in fire or explosion as well as serious injury or death to you and/or others.
- If you see liquid gasoline in the engine compartment/bilge or smell gasoline vapors, **DO NOT** attempt to start the engine. Liquid gasoline in the bilge is an extreme fire and explosion hazard which may cause injury or death. Find and fix the source of the leakage; remove the liquid gasoline from the bilge. Then ventilate the engine compartment/bilge and run the blower to remove all gasoline vapors before starting the engine.
- If gasoline vapors persist after running the blower, **DO NOT** attempt to start the engine. Likely, there is a gasoline leak that is creating the excessive vapor.
- Always operate the blower below cruising speed and after stopping the boat.



## Precautions While Underway



**Failure to follow these precautions will result in serious injury or death.**

*The operator shall:*

- Check that the area behind the boat is all clear before starting the engine(s) to **AVOID PROPELLER INJURY** to persons in the water behind the boat or on the swim platform.
- Turn off the engine(s) prior to anyone occupying the swim platform or being in the water behind the boat to **AVOID PROPELLER INJURY**. Being in neutral gear is insufficient; the propeller may still be turning, or the engine(s) may be inadvertently shifted into gear.
- Not back the boat toward persons in the water behind the boat to **AVOID PROPELLER INJURY**.
- Not allow people to be on or near the swim platform, where equipped, or in the water near the swim platform while the engine(s) is running because **CARBON MON-OXIDE** will exist around the back of the boat when the engine(s) is running. Engine exhaust contains carbon

monoxide, which is a deadly, odorless, colorless gas.

- Not operate the engine(s) in a confined space or while tethered to another vessel as **CARBON MONOXIDE** will be around the boats.
- Not go under the boat cover with the engine(s) running or shortly after the engine(s) has been running because **CARBON MONOXIDE** may remain under the cover. Remove cover to ventilate the area.
- Follow safe operating practices, the “Rules of the Road,” and the Water-sports Responsibility Code.
- Not operate a boat if under the influence of alcohol or other drugs.
- Attach the emergency cutoff switch lanyard to the boat operator when operating the boat.
- Maintain a proper course and safe speed at all times to avoid collisions.
- Maintain a lookout for other boats, swimmers, and obstructions in the water.
- Operate slowly in congested areas such as marinas and mooring areas.
- Keep a safe distance from other boats, swimmers, personal watercraft, docks, and fixed objects.
- Look before you turn/maneuver the boat so as to avoid potential collisions with oncoming or overtaking vessels.
- Be aware that this boat is a high-performance boat and is capable of quick, tight turns and changes in direction. Familiarize yourself with the handling characteristics of the boat. It is the operator’s responsibility to operate the boat in a manner that ensures the safety of all passengers. Abrupt maneuvers may result in the ejection of unsecured, unseated, or improperly positioned passengers. Verbally warn passengers before making quick, tight turns so they may have time to grasp a handrail, handhold, or portion of the boat.
- Be aware that your boat will handle differently, depending on loading and on-board weight distribution.
- Ensure that all passengers are properly and securely seated in appropriate seating locations to avoid falling or falling overboard.
- Instruct and ensure that passengers remain properly seated at all times while the boat is in motion above



- idle speed.
- Not allow passengers to sit on the transom, seat backs, engine cover or sides of the boat while the engine(s) is running, and the boat is in motion, to avoid falling overboard.
- Not allow passengers to sit in a position that obstructs the operator’s view.
- **NEVER** leave children unattended and in the boat without adult supervision.
- Have children riding in the bow of the boat be accompanied by an adult in the bow and ensure that all remain seated when the boat is in motion.
- Not let passengers occupy seats which may be in the path of the tow line.
- Slow down when crossing waves or wakes in order to minimize the impact on passengers and the boat. Crossing waves or wakes at an angle (such as 45 degrees) rather than perpendicularly will reduce the severity of the impact. Avoid rough water, large waves and large wakes from other boats when at high speed. Jumping waves/wakes or slamming the bow will cause large vertical impacts which may cause injury to occupants or cause ejections.
- For safe towing (water skiing, tubing, wakeboarding, wake surfing, knee boarding, etc.) be experienced and have an observer (an observer or “spotter” is required by law in most states). A rear-view mirror is helpful if you are allowed to tow without an observer in your state.
- Avoid letting tow lines or mooring lines wrap around anyone’s body parts/limbs. Doing so could allow body parts/limbs to become entangled in the line and could cause significant injury, such as amputations.
- Keep track of tow lines and dock lines so that they

do not become entangled in the propeller. A tow line will wrap quickly around a spinning propeller and is capable of immobilizing the boat and dragging a person entangled in the tow line underwater or causing amputations. Shut off the engine(s) if a tow line has potential for wrapping in the propeller.

- The tower is designed to pull a single individual. Please consult the remainder of this manual and/or warning labels on the tower for details. **DO NOT** climb, sit on, stand on, or jump/dive off of the tower. The tow line may loop on inverted tricks. **DO NOT** sit behind the pulling point of the tower.
- **NEVER** allow any type of spark or open flame on board. It may result in fire or explosion.
- Avoid grounding the boat: Be familiar with local conditions and water depth. If you are uncertain, then proceed slowly with caution. Sudden groundings from planing speeds may cause rapid decelerations and cause occupants to impact the boat and/or to be ejected from the boat. Boat damage may also occur.
- Always watch for low obstacles such as tree limbs, bridges or power lines, especially in boats with tow towers.
- Seek shelter from open water if there is threat of lightning or severe weather.
- **NEVER** dive from the boat without being absolutely sure of the depth of the water. Severe injury or death may occur from striking the bottom or submerged objects. Striking the bottom or a submerged object while diving headfirst can cause paralysis, head injury or death.
- Provide assistance to other boaters in distress while ensuring the safety of your own passengers.
- When you leave the boat, take the keys with you. This will keep untrained and unauthorized persons from operating the boat. (This will not be applicable on some keyless ignition systems.)



## Safety While Maintaining the Vessel



**Failure to follow these precautions may result in severe injury or death to you and/or others.**

*The operator shall:*

- Visually inspect the engine compartment, where equipped, and ventilate after refueling.
- Inspect the fuel system regularly. Examine fuel tanks, hoses and fittings for leaks or corrosion at least annually

because leaking fuel is a fire and explosion hazard.

- Never remove or modify components of the fuel system in any way except for maintenance by qualified personnel. Tampering with fuel components may cause a hazardous condition which could lead to a fire or explosion.
- Never override or modify the engine neutral starting safety switch in any way. Your boat engine(s) should not start in gear. If it does, do not use the boat until this safety feature is fixed by an authorized dealer.
- Be aware that batteries generate small amounts of dangerous hydrogen gas when charging. This gas is highly explosive. Keep all sparks, flames and smoking well away from the area. Failure to follow instructions when charging a battery may cause an explosion of the battery or the atmosphere near the battery, which could result in death or serious injury.
- Keep the engine(s) off whenever the engine box/cover/hatch, if equipped, is open. The engine box/cover/hatch serves as a machinery guard. Clothing or body parts can get caught in moving parts, causing death or serious injury. Keep away from moving parts.
- Not replace your boat's marine parts with automotive parts or parts that were not designed for your boat.
- Be aware that battery electrolyte fluid is dangerous. It contains sulfuric acid, which is poisonous, corrosive and caustic. If electrolyte fluid is spilled or placed on any part of the human body, immediately flush the area with large amounts of clean water and immediately seek medical attention.
- Check the tightness of the tower bolts **BEFORE** each use. If a tower collapses, it may result in injury to boat occupants or towed persons.
- Not modify the tow bar. The tow pylon/bar is not designed for vertical extensions. Any modifications to the tow pylon/bar or its mountings may result in damage to the boat and injury to the user.
- Only lift the boat from approved lift points, which are identified in later parts of this owner's manual.



# OWNER RESPONSIBILITY AND BOATING EDUCATION

## Basic Understanding

The following briefly explains many of the systems onboard.

### Propulsion System

A propulsion system consists of an engine turning a shaft that transfers power to a propeller. Some boats are equipped with more than one. Mounting may be as outboards, or as stern drive (inboard engine/outboard propeller).

### Remote Control System

The shift levers and throttle levers are connected to the engine(s) and propulsion unit(s) by mechanical push/pull cables. The shift lever controls the direction of the boat, and the throttle lever controls the speed of the boat.

### Steering System

The steering wheel (helm) is connected to a hydraulic cylinder. As the steering wheel is turned, hydraulic fluid directs movement of a steering cylinder. The cylinder is mechanically connected to the drive units.

### Fuel System

The fuel system consists of a permanent tank with an air vent system, fuel level sensor and fuel fill components. The tank has an anti-siphon valve to prevent fuel from accumulating in the bilge if a hose breaks.

### Ventilation System

The ventilation system removes fuel fumes by using blowers from the engine compartment (where equipped) and takes in fresh air through vents. Always keep vents free from obstructions.

 **DANGER**

**Operate the blower for at least four (4) minutes each time the engine is started. In addition, the blower should be operated continuously when the boat is stopped, operating at cruising speed or when the generator is running.**

Store flammables only in approved, vented containers securely fastened in a locker sealed from the interior of the boat and vented out of the side of the boat. Storing flammables in areas not designed for vapor removal creates a hazard.

Be aware of carbon monoxide from this and other boats. Allow air movement to dissipate the fumes. More information about carbon monoxide follows.

## Electrical Systems

 **DANGER**

**Never use an open flame in the battery storage area. The battery will explode if a flame or spark ignites the free hydrogen gas given off during charging. Be sure to prevent sparks near the battery.**

 **WARNING**

**Only a qualified marine electrical technician should service the boat's electrical system. Disconnect the electrical system from its power source before performing maintenance. Never work on the electrical system when it is energized. Electrical appliances must not exceed the rated amperage of the boat circuit. Observe the electrical system carefully while it is energized. The only electrical components that can be left unattended are the automatic bilge pump, fire protection and alarm circuits.**

 **CAUTION**

**Always turn off the engine before servicing the battery. Disconnect the battery cables before working on the electrical system to prevent arcing or damage to the engine's alternator. Disconnect the negative (-) cable first, and then disconnect the positive (+) cable.**

Cobalt boats can be equipped with one or two electrical systems. A direct current (DC) system is battery-powered and supplies electricity to lights, pumps, blowers, engine ignition and sometimes a refrigerator. An alternating current (AC) system is shore power or generator and supplies electricity to the electrical outlet, air conditioning, battery charge and other 110V AC or 220V AC appliances or components. Do not exceed rated amperage of electrical circuits.

If the boat is equipped with an optional battery charger, it must be plugged in only into a Ground Fault Circuit interrupter (GFCI)-protected AC outlet. When using an extension cord, connect the charger AC plug first before connecting the extension cord to the GFCI outlet.

Make the connection in an open area, free of any explosive fumes. The connections must be secure to avoid contact with any water.

### Cooling System

The engine(s) and generator, if equipped, are cooled by the continuous intake of raw water through independent water intakes. The water flows to water pumps on the engine(s) and/or generator for circulation around internal components.



The engine water intakes and outlets are located in the drive units. A generator water intake is at the bottom of the hull and the exhaust is usually on the side of the boat, above the waterline.

If your boat is equipped with an air conditioner, the water intake for it is in the bottom of the hull and exits from the side.

Cobalt boats may be equipped with a self-contained cooling system that pumps a mixture of fresh water and antifreeze through a large heat exchanger to reduce temperatures. Raw water is circulated through the other side of the heat exchanger to dissipate heat absorbed by the coolant mixture.

### Exhaust System

The engine and generator exhaust systems, if equipped, remove the gasses produced by the running engine, and vents them away from the boat. Engine exhaust is usually vented through the drive unit propeller but may be diverted through the transom with the optional captain's call exhaust system. Engine and generator cooling water are also removed along with the exhaust gases.

Never change the original exhaust system configuration. Inspect the entire exhaust system for tightness before each use. Leaks permit carbon monoxide exposure.

Some boating areas require the use of a muffler to reduce exhaust sound levels. In these instances, consult with an authorized Cobalt dealer for assistance.

### Lubrication System

The engine(s) and generator, if equipped, use a pressurized continuous loop lubrication system that must be periodically serviced in accordance with the manufacturer's recommendations.

The engine(s) has/have electrical transducer units to provide oil pressure signals to gauges at the helm. Full oil pressure must be available for proper lubrication, so monitoring the gauges is important, especially when operating at cruising speeds and above.

### Bilge

A drain plug is located in the transom to allow water to drain before trailering and storing. Before every use, inspect the drain plug and bilge pump. Routinely clean the pump strainer, float switch, intake, and area under the pump. It is a violation of federal law to pump overboard the contents of the bilge if such contains oil or fuel.



**WARNING**

**Always install the drain plug before launching the boat, to prevent the boat from sinking.**



## Important Safety Information

Your safety, the safety of your passengers, and the safety of other boaters is dependent on how you operate and maintain your boat. As operator or owner of this boat, you are responsible for the safety of those with and around you while boating.



## Responsibilities of Boat Owner and Operators

It is the owner's responsibility to ensure that the operator of the boat has been properly instructed in the lawful and safe operation of this vessel. Therefore, before operating the boat, thoroughly read this owner/operator manual. Be sure you understand each item before operating it. Improper operation or trailering of the boat could lead to severe personal injury or death. Improper operation or trailering of the boat may also damage the boat.

**The operator and the boat owner assume all risks for themselves, their guests and anyone in proximity to their boat, and ensure that all passengers understand the risks and responsibilities associated with boating.**

This manual is not intended to provide complete training on all aspects of boat operation. We strongly recommend that all operators of this boat seek additional training on boat handling and safety. Have all operators become familiar with the handling characteristics, and proper steering and control system usage before attempting high-speed operation.

*At the time of delivery, the owner/operator is responsible for:*

- Understanding the warranty terms and conditions of your boat, your engine, and your trailer.
- Obtaining insurance.
- Examining the boat to ensure the proper operation of all systems.

*Before operating the boat, the owner/ operator is responsible for:*

- Registering the boat as required in the jurisdiction where the boat is being operated.
- Providing the proper (USCG) safety equipment, and checking local, state and federal agencies as to laws and regulations (USCG carriage requirements).
- Carefully reading and understanding safety information and proper operating procedures within this manual.
- Obtaining other boating education if you lack operational experience.
- Familiarizing yourself with the navigable waters where you intend to operate the boat.
- Following the proper break-in procedure for the engine(s).





## Registration

Federal law requires that all motorboats be registered and that all motorcraft not documented by the U.S. Coast Guard display registration numbers. In nearly all states, this means registration with a designated state agency. In a few jurisdictions, the Coast Guard retains registration authority. Your dealer will either supply registration forms or tell you where they may be obtained. The agency will supply you with a certificate which must be carried with you when the boat is in operation.

International laws may vary as to required registration.



## Insurance

The boat owner may be legally responsible for damages or injuries caused by both himself and the operator (if different than the owner). Common sense dictates that you carry adequate personal liability and property damage insurance on your boat, just as you would on your automobile. Many states have laws detailing minimum insurance needs. Your insurance agent or your dealer may be able to supply you with more information. You should also protect your boat from physical damage or theft.



## Boating Safety Education Opportunities

It is recommended that the boat owner/operator obtain boater safety education. If you have never owned a boat before, you can get an excellent introduction to boat handling from organizations such as the U.S. Coast Guard, American Red Cross, United States Coast Guard Auxiliary, or your local boating authority. Even if you are a veteran boater, these courses will help sharpen your boating skills as well as bring you up to date on current rules and regulations. See your local boating agency or dealer for information on classes in your area.

Some states require youths, 16 years of age and younger, to complete a boating safety course before operating any watercraft. Many others require operators under the age of 18 to be licensed in small boat operation.

Boat smart from the start: Take a boating safety course and get a free vessel safety check annually for your boat.

For more information, contact: United States Coast Guard Auxiliary, [www.cgaux.org](http://www.cgaux.org); United States Power Squadrons, 1-888-FOR-USPS, [www.usps.org](http://www.usps.org).

The following is a list of some other agencies and organizations that offer Water Safety, First Aid and CPR courses or information. To find boating safety courses in your area, call your state's local boating agency or the USCG boating safety course line at 1-800-336-2628 (1-800-245-2628 in Virginia).

- USCG Office of Boating ([www.uscgboating.org](http://www.uscgboating.org))
- American Red Cross ([www.redcross.org](http://www.redcross.org))
- U.S. Coast Guard Auxiliary ([www.cgaux.org](http://www.cgaux.org))
- U.S. Power Squadrons ([www.usps.org](http://www.usps.org))
- State Boating Offices
- Canadian Power and Sail Squadrons ([www.cps-ecp.ca](http://www.cps-ecp.ca))
- Boat Owners Association of the United States ([www.boatus.com](http://www.boatus.com))
- National Safe Boating Council ([www.safeboatingcouncil.org](http://www.safeboatingcouncil.org))
- Water Sports Industry Association ([www.wsia.net](http://www.wsia.net))
- European or international organizations



## Operation by Minors and Licensing

If your boat will be operated by a minor, remember to have an adult present at all times. Many states have laws regarding minimum age and licensing requirements for minors.

Some states require boat training courses, certification, or licensing for minors and/or adults. Contact state and local authorities for requirements that apply in your area.

Your boat and equipment must be in compliance with federal, state and local safety equipment regulations. USCG regulations require certain safety equipment be present on your boat during operation. For a detailed description, obtain "Federal Requirements for Recreational Boats" published by the U.S. Coast Guard and available online at:

<http://www.uscgboating.org/images/420.PDF>

In addition to the USCG regulations, other local and/or international law enforcement agencies may have similar requirements. You should check with your local marine law enforcement agency regarding any such requirements before boating.

# SAFETY AND REQUIRED EQUIPMENT

Equipment requirements for coastal and inland waters differ. Check with local authorities and/or the USCG for further information about coastal water requirements.

The Federal Boat Safety Act of 1971 (FBSA/71) and the National Recreation Boating Safety Program have established minimum safety standards for boats and associated equipment, specified by the USCG. In addition, the American Boat and Yacht Council (ABYC) and the National Marine Manufacturers Association (NMMA) work with boat builders to develop voluntary standards that exceed the USCG requirements. The included safety equipment on your boat meets or exceeds the standards of the USCG, ABYC and the NMMA.

Some required safety equipment, such as life jackets (PFDs), are not included with your boat purchase. Your dealer can help you choose the appropriate equipment.

## NOTICE

**Many states' equipment requirements go beyond USCG requirements. Contact your state boating office for further information.**

## Navigation Lights

Your boat is equipped with navigational lights. Recreational boats are required to display navigational lights between sunset and sunrise and other periods of reduced visibility (fog, rain, haze, etc.). Navigation lights are provided to keep other boats informed of your presence and course. It is up to you to make sure they are operational, displayed correctly, and turned on when required.



## Compass

To aid in navigation, Cobalt boats may be equipped with a compass mounted at the helm. Refer to the compass user's manual in the owner's packet for operating information. The compass may require calibration. Contact your authorized Cobalt dealer for assistance.

## Other Navigation Equipment

Other navigation equipment, such as depth sounder radar, LORAN system or global positioning system, can be installed by an authorized Cobalt dealer. Operation and maintenance of that equipment is provided by the manufacturer.

## Emergency Safety Stop Switch

Your boat is equipped with an Emergency Safety Lanyard (cutoff switch). We recommend that the lanyard be secured to the operator and the lock plate attached to the emergency cutoff switch prior to starting the engine(s) and anytime the engine(s) is operating. The

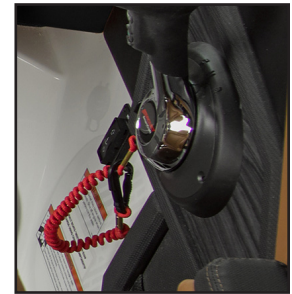

Emergency Safety Lanyard is designed to turn off the engine(s) whenever the operator moves far enough away from the helm to activate the switch. The purpose is to stop the engine(s), propeller, and boat in the event the operator leaves the helm location, falls overboard, or is ejected from the boat. If the engine(s) is stopped it will prevent the boat from becoming a run-away, unmanned boat, which may cause injury or death to boat occupants who have fallen overboard or been ejected, or to other nearby people. If the engine(s) stops, it will minimize the subsequent opportunity for propeller contact with the operator or other persons in the water. If the engine(s) and boat stop it will afford opportunity for the operator or other persons who have fallen overboard to safely re-board the boat.

## WARNING

**It is required by law that you use the Emergency Safety Lanyard system because failure to do so can cause death or serious injury. DO NOT operate the boat if the Emergency Safety Lanyard system does not function properly.**

- Attach the Emergency Safety Lanyard to a secure place on your clothing, your arm or your leg while operating.
- **DO NOT** attach the lanyard to clothing that could tear loose.
- **DO NOT** route the lanyard where it could become entangled, preventing it from functioning.
- Avoid accidentally pulling the lanyard during normal operation.
- Loss of engine power means loss of most steering control.
- Without engine power, the boat will decelerate rapidly. This could cause people in the boat to be thrown forward or ejected overboard if they are not properly seated in the boat.

There are practical limitations to what the Emergency Safety Lanyard can do. It can take several seconds for the engine(s) and propeller to stop turning. The boat can continue to coast for several hundred feet depending on the boat speed at the time the switch is activated. While the boat is coasting, it can cause injury to anyone in its path. Accidental loss of power can be hazardous particularly when docking or in heavy seas, strong current, or high winds.

While at the dock or when the boat is not moving, periodically disconnect/pull the Emergency Safety Lanyard out of the switch while the engine is running to test for proper operation. The engine(s) should shut off when the lanyard is disconnected/pulled from the switch. You should not be able to restart the engine(s) until the lanyard is back in place.



## Personal Flotation Devices

Federal law requires that you have at least one wearable Personal Flotation Device (PFD) of the proper size (Type I, II, III or V), for each person on board or being towed, and at least one throwable PFD (Type IV) in the boat. PFDs must be Coast Guard-approved, in good and serviceable condition and the appropriate size for the user. To meet requirements, each lifesaving device must



have a current, legible USCG approval stamp permanently affixed. At the beginning of each season, inspect life jackets (PFDs) for damage and test for proper flotation. Refer to the life jacket (PFD) manufacturer's information.

**REMEMBER—The best PFD is the one that is worn—that is, the one that can save your life.** PFDs are intended to save lives; it is highly recommended that you and your passengers wear them while in the boat. Learn how to use them and adjust as necessary for comfort. It is especially important that children and non-swimmers wear a life jacket (PFD) at all times. Make certain all passengers know where life jackets are located, how to put on and properly adjust their life jackets (PFDs), and that life jackets are readily accessible at all times.

Your dealer can help you select appropriate life jackets (PFDs) and throwable lifesaving devices for your area. Some PFDs are specially made for use while water skiing or wakeboarding and are not USCG-approved. Please check local law with respect to their use. Some states require children to wear a PFD at all times. There are four types of wearable PFDs (Type I, II, III or V) and one throwable type of PFD (Type IV) used for throwing in emergency situations. Examples of these USCG-approved PFDs are shown:

### Type I PFD—Offshore Life Jacket:

This PFD is designed for extended survival in rough, open water. It usually will turn an unconscious person face up and has over 22 pounds of buoyancy. This is the best PFD to keep you afloat in remote regions where rescue may be slow in coming.



### Type II PFD—Near Shore Buoyant Vest:

This “classic” PFD comes in several sizes for adults and children and is for calm inland water where there is chance of fast rescue. It is less bulky and less expensive than a Type I, and many will turn an unconscious person face up in the water.



### Type III PFD—Flotation Aid:

These life jackets are generally considered the most comfortable, with styles for different boating activities and sports. They are for use in calm water where there is good chance of fast rescue since they will generally not turn an unconscious person face up. Flotation aids come in many sizes and styles.



**Type IV—Throwable Device:**

These are designed to be thrown to a person in the water. Throwable devices include boat cushions, ring buoys, and horseshoe buoys. They are not designed to be worn and must be supplemented by wearable PFD. It is important to keep these devices immediately available for emergencies.



**Type V PFD—Special Use Device:**

Special use PFDs include work vests, deck suits, and hybrids for restricted use. Hybrid vests contain some internal buoyancy and are inflatable to provide additional flotation. These PFDs may be used instead of a Type I, II, or III PFD with non-towed participants if used in accordance with the approval conditions on the label and if worn when the boat is underway. Some Type V PFDs provide increased protection against hypothermia.



**NOTICE**

A Type V PFD must be worn to be counted toward the minimum carriage requirements.

**NOTICE**

Special life jackets are available for skiing and other watersports. These non-Coast Guard-approved life jackets do not count as PFDs.



**Fire Extinguisher**

A portable fire extinguisher is required if your boat has an inboard engine, or when fuel is stored in closed stowage compartments.

Approved fire extinguishers are classified by a letter symbol, either B-I or B-II with the B designating that the material will extinguish flammable liquids such as gasoline, oil, etc. B-I extinguishers are required for boats less than 26 feet in length. Check periodically to ensure that the extinguisher is in working condition and fully charged. Check local, state and federal agencies as to laws and regulations.



**Horn or Whistle**

All boats over 16 feet (4.8 meters) in length must be equipped with an operable horn or whistle. Test the operation of the horn periodically, so as to make sure it will sound when you actually need to alert someone or another boat. The following are standard signals when using a whistle or a horn:

- **One prolonged blast:** Warning.
- **One short blast:** Pass on my port (left) side.
- **Two short blasts:** Pass on my starboard (right) side.
- **Three short blasts:** My engines are in reverse.
- **Five or more blasts:** Danger!



**Bilge Pump(s)**

Bilge pump(s) are installed in your boat to remove water that may accumulate in the bilge. Know the location of the pump(s), where they discharge, and where switches are located. Typically, there are manual switch and/or an automatic switch position(s).

Periodically test the operation of bilge pumps by activating the manual switch and observing the water discharge. It is best to leave the bilge pump switches in automatic mode, so as to not allow excess water to unknowingly accumulate in the bilge of your boat. If your bilge pump comes on too frequently or continuously, investigate the source of leaking water (check for hull damage, hose or piping leaks, missing drain plug, exhaust system or ballast system failures, etc.), and/or return to shore. Excess water in the bilge of your boat can cause loss of engine power, sinking, and/or capsizing.



**Visual Distress Signals**

 USE DAY ONLY	 RED DISTRESS FLARE (HAND) USE DAY AND NIGHT
 ARMS SIGNALS (USE BRIGHT CLOTH) USE DAY ONLY	 SIGNAL (HAND) USE DAY ONLY
 ELECTRIC DISTRESS LIGHT USE NIGHT ONLY	 RED METEOR FLARE USE DAY AND NIGHT
	 DYE MARKER USE DAY ONLY

COB\_0031\_A



All vessels used on coastal waters, the Great Lakes, territorial seas, and those waters connected directly to them up to a point where a body of water is greater than two miles wide, must be equipped with USCG-approved visual distress signals. Your dealer or local authorities can help you select appropriate visual distress signals for your area.

If you are required to carry distress signals, you must have three USCG-approved pyrotechnic devices. Be sure they are in serviceable condition, not exceeding the expiration date and stored in a cool, dry location in a red or orange waterproof container.

 **WARNING**

**Pyrotechnic signaling devices can cause fire and/or explosion, death, serious injury, and property damage if improperly handled. Follow the pyrotechnic manufacturer's directions.**



## Radio Communications

Radio communication is the most important avenue of receiving and sending information. Use a VHF/FM radio for short-range communication, and a single-side-band radio (SSB) for long-range. For all U.S. waters, the National Weather Service operates the NOAA Weather Radio (NWR). This service provides continuous weather information the following *VHF/FM frequencies*:

162.400 MHz	162.500 MHz
162.425 MHz	162.525 MHz
162.450 MHz	162.550 MHz
162.475 MHz	

*Coast Guard Marine Information Stations*

2670.0 kHz	8765.4 kHz
4428.7 kHz	13113.2 kHz
6506.4 kHz	

It is good practice to periodically monitor the weather, even on seemingly fair-weather outings.

VHF/FM Channel 16 and SSB 2183 kHz are designed for emergency use. Such situations can be categorized as:

- **Emergency**  
**"MAYDAY, MAYDAY, MAYDAY"**—Used when a life or vessel is in imminent danger.
- **Urgency**  
**"PAN-PAN, PAN-PAN, PAN-PAN"** (pronounced *PAHN-PAHN*)—Used when a person or vessel is in some jeopardy less than indicated by a Mayday call.
- **Safety**  
**"SECURITY, SECURITY, SECURITY"** (pronounced *SAY-CURE-IT-TAY*)—Used for navigational safety or weather warning.

An emergency situation will be hectic and there will not be time to learn proper radio procedure. **LEARN WHAT TO DO BEFORE YOU NEED TO DO IT.**

When a distress call occurs, stop all radio transmission. If you can directly assist, respond on the emergency frequency. If you cannot assist, do not transmit on that frequency. However, continue to monitor until it is obvious that help is being provided.

Note that some areas may require a license to operate radio-telephone equipment. Consult an authorized Cobalt dealer for information.



## Recommended Safety Equipment

As a precaution, a prudent boater will avoid potential problems on an outing by having additional equipment on board. Normally, this equipment is dependent on the size and type of the body of water and the length of the trip. Your dealer can assist you in acquiring this additional equipment.

*We recommend the following equipment:*

- First aid kit and manual
- Anchor with at least 75 feet (23 meters) of line
- Mooring lines and fenders
- Bailing device (bucket, hand pump)
- Binoculars
- Combination paddle/boat hook
- Local charts and compass
- Day (flag)/night (flares) distress signals
- Waterproof flashlight and spare batteries
- Cellular phone
- Waterproof container for cell phone
- GPS Global Positioning System
- Emergency Position Indicating Radio Beacon (EPIRB)
- Binoculars
- Portable AM/FM radio with weather band
- A non-electric horn or whistle
- Extra engine oil
- Tool kit
- Spare propeller and mounting hardware
- Spare fuses
- Spare keys
- Sunglasses and sun block lotion





## Recommended Spare Equipment

The following list contains common equipment that should be carried onboard to be available to make minor repairs as necessary.

- Lanyard for ignition safety switch
- Engine oil and generator oil
- Hydraulic fluid for the steering system and trim system
- Ignition keys
- Tape, tie straps and rope
- Light bulbs and fuses
- Propeller with attaching hardware

## Life Raft

When operating offshore, consider carrying an inflatable life raft. A USCG-approved life raft meets a number of stringent specifications. The life raft must be large enough to hold all the boat's occupants and have its own equipment pack, including a paddle.

A life raft can be stored in the aft storage area or in any other accommodating location on the boat.

# GENERAL BOATING SAFETY TOPICS

## Safe Speed

Navigation rules state that a boat be operated at a safe speed at all times. Determination of a safe speed involves consideration of many factors, such as, but not limited to:

- Boating activity (tubing, water skiing, wakeboarding, wake surfing, etc.)
- Boat traffic congestion
- Water conditions
- Environmental conditions (shoreline, docks, and depth of water)
- Weather
- Visibility

The boat should not be driven at a rate of speed faster than will allow it to be brought to a full stop within the operator's field of view given the environmental conditions at the time. Safe speed for the conditions and driver attention (lookout) are important factors in avoiding collisions which may cause injury or death. When in doubt it is prudent to slow down within adequate time and distance so as to be able to assess the conditions and paths of other boats.

It is important to know the *Rules of the Road*, although do not assume that all boaters also know the rules or that they will abide by them. Avoid collisions by constantly assessing the ever-changing situation and be sure to make appropriate speed and course changes early.



## Passenger Safety

The operator of the boat is responsible for the safety of the passengers, all skiers/riders, as well as his/her own safety. Ensure that you and your passengers adhere to these safety recommendations:

- Any time you take your boat out, make sure that there is at least one other passenger aboard who is familiar

with the operation of your boat.

- Ensure that all passengers are properly and securely seated in appropriate seating locations to avoid falling or falling overboard.
- While the engine(s) is running, and while the boat is maneuvering, all occupants should be properly seated. **DO NOT** stand while the boat is moving.
- **DO NOT** sit on the engine box (where equipped), seat backs, transom seating, sun pad, swim platform or gunwales while the boat is underway. You could fall overboard and be hit by the propeller, or another boat.
- **DO NOT** allow objects, arms or legs, or any other body parts to hang over the bow or gunwales. Stay within the boat.
- Passengers should not sit in locations that obstruct the operator's visibility.
- Persons and gear should be stowed in a way that distributes weight appropriately and in a manner that trims the boat properly (pitch angle). Excessive weight at either the bow or the stern relative to one another can cause trim problems leading to reduced driver visibility, erratic steering, loss of control, or bow submergence and flooding/swamping.
- Passengers should be well aware of emergency equipment and instructed in its use.
- Passengers should assist with lookout duties and notify the operator of any approaching watercraft or potentially unsafe conditions to provide assistance with collision avoidance.



## Carbon Monoxide Safety

Carbon Monoxide (CO) is a deadly, colorless and odorless gas produced by all engines and fuel-burning appliances. Even with the best boat design and construction, plus the utmost care in inspection, operation and maintenance, hazardous levels of carbon monoxide may be present in or



near the boat under certain conditions. The boat owner, operator, as well as all boat occupants, must understand the dangers of carbon monoxide and must comply with all safety recommendations/ requirements. For boats with cabins, always ventilate the boat interior and avoid boating situations which cause increased exposure.



**Carbon monoxide (CO) can cause brain damage or death. Engine and generator exhaust contains odorless and colorless carbon monoxide gas. Carbon monoxide will be around the back of the boat when engines or generators are running. Move to fresh air, if you feel nausea, headache, dizziness, or drowsiness.**

- **DO NOT** allow people to be on or near the swim platform or in the water near the swim platform while the engine is running. Carbon monoxide will exist around the back of the boat when engines are running.
- **DO NOT** operate the engine in a confined space or while the boat is tethered to another vessel.
- **DO NOT** go under the boat cover while the engine is running or shortly after the engine has been running. Carbon monoxide may be trapped under the cover. It is important to remove the cover and/or ventilate the area before going under the boat cover.
- **DO NOT** “platform/teak” surf or platform drag. Carbon monoxide will exist in high concentrations in the vicinity of the swim platform near the water while the engine is running. The USCG has deemed platform dragging as a dangerous and hazardous activity which should be prohibited, as it can result in injury or death.
- In the event that someone exhibits the symptoms of carbon monoxide exposure (nausea, headache, dizziness, or drowsiness), have them breathe fresh air and, if necessary, immediately seek medical attention.

Hazardous boating situations involving carbon monoxide include:



*Blockage of boat exhaust by obstruction.*

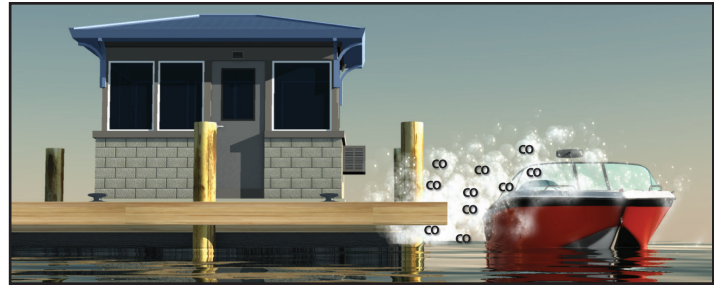

*Exhaust traveling along obstruction.*

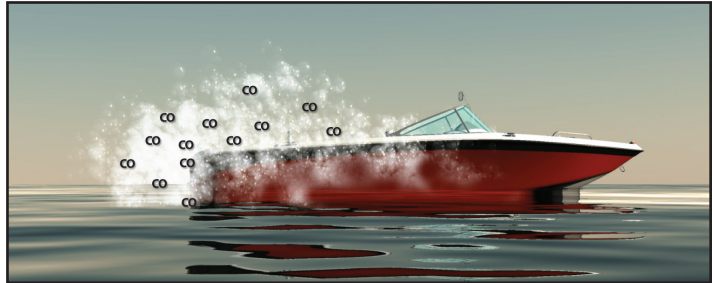

*Operating at slow speed or while dead in the water.*

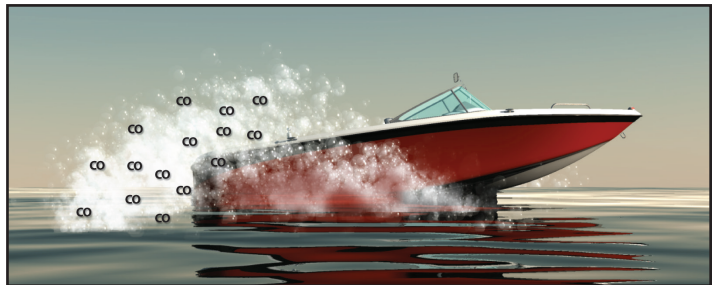

*Operating with high bow angle.*

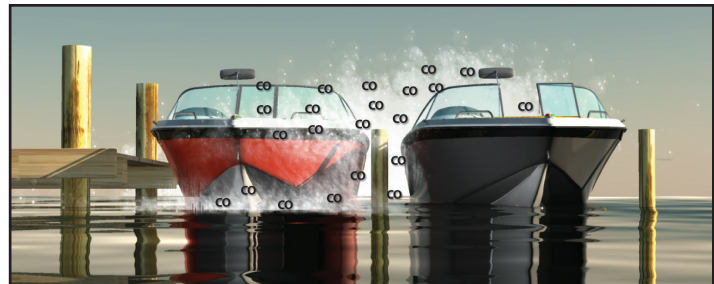

*Exhaust from other vessels in confined areas.*

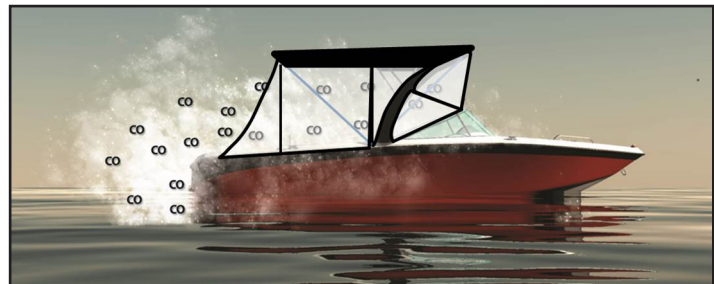

*Operating with canvas tops and side curtains in place without ventilation.*



For the most current information on carbon monoxide, you may call, write or visit online any of the following:

**United States Coast Guard**  
Office of Boating Safety (CG-5422)  
2100 Second Street SW STOP 7581  
Washington, DC 20593-7581  
(www.uscgboating.org/safety/carbon\_monoxide.aspx)

**NMMA**  
231 S. LaSalle St., Suite 2050  
Chicago, IL 60604  
312-946-6200  
(www.nmma.org)

**American Boat & Yacht Council, Inc.**  
613 Third Street, Suite 10  
Annapolis, MD 21403  
410-956-4460  
(www.abycinc.org)



## Proper Loading



**WARNING**

**DO NOT overload your boat. Overloading or uneven loading can cause loss of control, capsizing, or swamping, which may lead to death or serious injury. Adhere to the load capacity plate restrictions, and always account for persons, gear, and all non-factory-installed ballast or other equipment.**

Your boat is equipped with a maximum load capacity plate indicating the maximum acceptable load as determined by the manufacturer following certain Federal guidelines. In addition to following these weight guidelines, it is critical that you properly distribute this weight throughout the boat. If too much weight is placed in one area it can have serious impact on the boat's handling and control, which has the potential to lead to injury or death.

The maximum load capacity plate is used by boat manufacturers participating in the National Marine Manufacturers Association certification program. Your manufacturer has submitted your model for inspection and compliance with their guidelines. The maximum number of persons allowed on the boat has been determined by the manufacturer and displayed on the capacity plate. (Additional information regarding weight distribution appears elsewhere in this owner's manual.) This information on the capacity plate applies under normal conditions, and special care must be used in any abnormal conditions. Check the capacity plate on your boat

and abide by these limits.

The capacity plate has the following information permanently printed on it:

- **The total weight of persons, gear and other items which the boat is capable of carrying under normal conditions. This weight must include any added ballast above and beyond boat manufacturer's factory-installed ballast system(s), such as the manufacturer's-approved, optional Plug 'n Play (which has been factored into the maximum capacity) or any other added, but unapproved ballast.**



**WARNING**

**Any non-factory-installed ballast must be properly secured to prevent injury.**



**WARNING**

**DO NOT fill the bilge area with water. Excessive water in the bilge can cause changes in boat trim and reduce boat stability which may lead to submergence or capsizing.**



## Weighting Your Boat During Watersport Activities

Although water intrusion and waves spilling inside a boat is an obvious boating hazard, this hazard can be increased when weighting your boat for water sports such as wakeboarding or wake surfing. As wakeboarding has evolved, ballast systems have been developed to add weight and increase the size of the wake. The simplest ballast system on the market is the water ballast type, such as the "FAT SAC." The quest for the largest wake has caused some boat operators to excessively overload their boats. It is not uncommon to see operators use aftermarket ballast systems and then put additional people and gear in their boat. Be advised that this practice can lead to overloading your boat which may lead to any of the following: changes in handling and performance; capsizing, flooding, and sinking; boat occupants going overboard. **DO NOT** overload your boat.

Always be aware of the load in your boat and do not load the boat in excess of the listed capacity. Each boat has a maximum capacity label displaying the maximum weight of people, gear and ballast that can be placed in the boat.

When loading your boat, give attention to the effect that the load distribution has on the boat's trim angle. Trim angle is the technical term for the up or down pitch angle of your boat (also known as the "bow up" or "bow down" angle). The fore and aft load distribution of weight, passenger, and gear can affect the running trim angle of the boat.



- Excessive weight placed in the stern of the boat can cause the inability to get on plane, high bow-up angles, and can lead to steering difficulties. High bow-up angles can be dangerous due to the reduction in the operator's forward visibility which can lead to collisions and groundings. High bow-up angles cause longer transition times from displacement mode (slow velocity, 0 to 5 mph) to planing speeds (18 to 20 mph and above). During transition, it is important that the boat operator pays attention so that they are able to see forward and that the time in transition (or in the "hump" speed region) is minimized.



- Excessive weight placed in the bow of the boat can lead to very flat planing trim angles which may lead the boat to turn aggressively, unpredictably, and without steer input. The phenomenon of yaw instability is caused by heavy bow weights and running very flat (bow down or flat trim angles). This can occur with excessive weight in the bow compared to weight in the stern of the boat. Another ill effect of too much bow weight in comparison to stern weight is that with extremely heavy bow loads, the boat's bow may dive or submerge when coming off plane (decelerating rapidly or encountering waves/wakes at slow speed). If the bow submerges, then water will enter and flood your boat.
- When encountering conditions which may lead to bow diving or bow submergence, it is recommended to accelerate the boat before the wave/wake in order to help raise the bow and get over the wave/wake.
- If the bow submerges, the recommended action is to reduce throttle to stop forward speed, get passengers to move aft, and turn on the bilge pump.

It is the boat operator's responsibility to tell passengers to move to other seats on the boat, so as to not overload the stern or bow of the boat, nor restrict the boat operator's forward visibility. There is no single recommended seating or load distribution for all conditions. Experience with your boat will allow you to determine where to properly allow passengers and gear to be placed.

**⚠ WARNING**

**Excess and improper loading of bow area forward of windshield may cause water influx, operating instability, and loss of control resulting in injury or death. Bow Capacity Limit—X persons or XXX lbs. person, gear and ballast. This is posted separately on your boat but still included in overall capacity. Use good judgment when weighting your boat for any towed water sports.**



### Visibility for the Operator

The operator of the boat is responsible, by law, to "maintain a proper lookout by sight and hearing." The operator must ensure that he/she has appropriate visibility for safe operation. No passengers or equipment should block the operator's view, including the view of other boats, skier(s), rider(s), swimmer(s), or anyone or anything else in the water. Even momentary interference can result in the driver's inability to respond to a situation that requires avoidance of another vessel or submerged or partially submerged object(s).

Look carefully before turning, especially when you are turning around to pick up a fallen skier/rider. Other boats in your vicinity may not necessarily be following the nautical Rules of the Road. Be alert and keep a visual check for other boats in and around your intended path. Do not turn or maneuver your boat without first checking that it is clear to do so. Failure to look before turning can result in an encounter with another boat where neither boat has enough time to avoid a collision. This situation can develop very quickly if you fail to look first and turn in front of another oncoming boat.

**⚠ WARNING**

**Obstructed visibility can cause death or serious injury. The operator must maintain clear visibility at all times while operating the boat. Arrange passengers and equipment appropriately or designate a passenger to assist when visibility is limited.**





## Boating Under the Influence



**WARNING**

**Operating the boat or boating under the influence of alcohol and/or drugs can cause serious injury or death. Alcohol and drugs slow your reaction time and impair your judgment. Do not operate a boat or allow passengers to boat while under the influence of alcohol and/or drugs.**

Boating under the influence of alcohol or drugs can be deadly. Alcohol and/or drug use is the leading contributing factor to all recreational boating fatalities. Alcohol and drugs can increase your reaction time and impair your judgment. Combined with the sun, wind, waves, and noise of other watercraft, the effects of drugs and alcohol can be increased and can significantly increase your reaction time. As the owner/operator, you are responsible for the alcohol/drug use and onboard behavior of your passengers. Additionally, civil lawsuits in cases of property damage or injury/death to others can result in significantly higher verdicts when alcohol or drugs are allowed.



**WARNING**

**Impaired operation may result in severe personal injury or death. Federal and state laws prohibit operating a boat under the influence of alcohol and other drugs. If the operator's blood alcohol content is above the legal limit, violators are subject to fines and may go to jail. Violators may also lose automobile driving privileges.**



## Product Misuse

Misuse of the product or use of it in a manner for which it was never intended can create dangerous situations. The boat operator and passengers are responsible for using the product safely and as intended. The driver must operate the boat in a manner that ensures the safety of all passengers. If you or your passengers are unsure about the proper use of the product, unsure about performing certain boating maneuvers or are unsure about a particular water activity, refer to this owner's manual or contact a knowledgeable source, such as your local dealer, the US Coast Guard, or your local boating authority.



## Reporting Accidents

Boat operators may be required by law to file a Boating Accident report with their state boating law enforcement agency or local authority, the USCG, or their country's boating law enforcement agency when their boat is involved in certain boating accidents. A boating

accident must be reported if there is a loss or probable loss of life or a personal injury requiring medical attention beyond first aid. In these situations, a formal report must generally be filed within 48 hours of the accident. Also, a boating accident must be reported for accidents when damage exceeding \$500 is incurred, or there is a complete loss of the boat. In these situations, a formal report must generally be filed within ten (10) days. If any of these events occur, seek further assistance from local law enforcement personnel. Please note that the submission of a report is the responsibility of the boat owner. This requirement is different than laws associated with the reporting of automobile accidents.



## Rendering Assistance

If you see a distress signal or suspect a boat is in trouble, you must assume it is a real emergency and render assistance immediately. By law, the operator in charge of the craft is obligated to provide assistance to any individual in danger, presuming assistance can be safely provided. Failure to render assistance can result in a fine and/or imprisonment.

The 1971 Boating Safety Act grants protection to a "Good Samaritan" boater providing good faith assistance and absolves a boater from any civil liability arising from such assistance.



## Hazardous Conditions

Every waterway poses hazards that should be avoided. You will be best prepared to avoid these hazards if you are familiar with the waterway where you are boating. Whenever possible familiarize yourself with navigation charts, depth charts, and waterway maps before you go boating. The following information outlines some of the most common hazards which may be encountered:

### Shallow Water Operation

Shallow water brings on obvious hazards such as sand bars, stumps, rocks, etc. Know the area in which you will be operating the boat. Grounding the vessel or striking submerged objects can result in serious injury or death and can cause severe damage to your watercraft. At high speed, this can cause rapid deceleration or stop your boat abruptly, which may cause occupants to impact the interior of the boat or be ejected. Stick to deeper water whenever possible, and if you must travel in shallow water, proceed at low speed and post a lookout.

Know the minimum depth your boat can safely travel.

### Warning Markers

Learn to recognize the different buoys and day markers; they are used as the signposts of the waterways identifying navigable routes and water hazards. It is a good idea to ask local authorities about hazard areas and if they are marked. Stay within boundaries and clear of hazards.

### Weeds

Weeds can generally be a threat to a boat's engine and other components on the boat. If weeds wrap around the propeller, they can create vibration in the engine(s). They also can restrict water intakes or clog the water filter, causing the engine(s) to overheat. Learn to recognize the typical normal operating temperature range for your engine(s). If temperature rises high above normal, then check for blockage of the engine cooling water system.

## NOTICE

**Weeds can sometimes be removed by shifting to NEUTRAL, pausing for a moment, then shifting to REVERSE to unwind the weeds from the propeller.**

### Dam Spillways

The area around dam spillways is very hazardous and conditions can change rapidly. Keep clear of the spillways and areas below dams. Currents created by spillways can draw in objects, including your boat.

### Restricted Areas







Before boating, check with Local, State, and Federal authorities to identify restricted areas. Because of the

threat of terrorism, the U.S. Coast Guard has and will continue to implement strict limits on watercraft near U.S. Navy and Coast Guard ships and other potential targets.

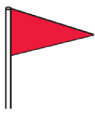
## Weather/Seas

Learn and understand weather patterns and signs of change. Bad weather can cause an uncomfortable and unsafe situation. If a storm approaches, seek a safe harbor. Check forecasts before getting underway and continue to monitor conditions while on the water.

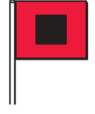
The adjacent are storm signals:

DAYTIME WARNING	DESCRIPTION	NIGHTTIME WARNING
	<b>Small Craft Advisory</b> - Winds greater than 18 knots, sustained for two hours or more or hazardous wave conditions. Following a storm, hazardous wave conditions can persist long after the high winds have subsided.	
	<b>Gale Warning</b> - Sustained winds (2 or more hours), of 34-47 knots.	
	<b>Storm Warning</b> - Sustained winds of 48 knots or greater.	
	<b>Hurricane Warning</b> - Forecast winds of 64 knots and above. Displayed only in connection with a hurricane.	

COB\_0032\_A

## Environmental Concerns

As a boater, you already appreciate nature's beauty and the peace of the great outdoors. It is a boater's responsibility to protect the natural environment by keeping waterways clean.

### Foreign Species

If you trailer your boat from lake to lake, you have the potential of unknowingly introducing a foreign aquatic species from one lake to the next. It is important to thoroughly clean the bottom of the boat below the water line, remove all weeds and algae, and drain the bilge, ballast, and livewells before launching the boat in a new body of water. Check local, state, country agencies as to laws and regulations.

### Fuel/Oil Spillage

The spilling of fuel or oil into our waterways contaminates the environment and is dangerous to wildlife. **DO NOT EVER** discharge or dispose of fuel, oil or other chemicals into the water; it is prohibited and can result in fines. These are three common, accidental types of discharge:

- During initial fueling of a nearly empty tank
- Overfilling the fuel tanks
- Pumping contaminated bilge water



## **WARNING**

**Fumes from rags can collect in the bilge and pose an extremely hazardous fire and explosion risk, which can result in injury or death. Never store rags used to wipe up fuel or solvent spills in the boat. Dispose of rags properly ashore.**

### **Discharge/Disposal of Waste**

Waste means all forms of garbage, plastics, recyclables, food, wood, detergents, sewage and even fish parts in certain waters—in short, nearly everything. We recommend you bring back everything you take out with you, for proper disposal ashore.

### **Excessive Noise**

Noise means engine noise, radio noise, music, loud conversation, or even yelling. Many bodies of water have adopted noise limits. Noise can carry a considerable distance on water, especially at night. Be sure to follow regulations and be courteous.

### **Speed/Wake/Wash**

Be alert for **NO WAKE** zones. You are responsible for any damage or injury caused by your wake/wash. Prior to entering a **NO WAKE** zone, reduce throttle, come off plane to the slowest steerable speed. Use caution when operating around smaller crafts, in channels and marinas, and in congested areas.

Some states and boating areas have imposed speed limits for the operation of boats, including, but not limited to, no-wake zones. Check local, state, and federal agencies as to laws and regulations. The U.S. Coast Guard and local boating authorities are excellent sources for this information, which can include penalties for failure to observe the requirements.

### **Exhaust Emissions**

Increased exhaust (hydrocarbon) emissions pollute our water and air. Keep your engine(s) tuned and boat hull clean for peak performance. Consult your Cobalt dealer for information.

### **Paints**

If your boat is kept in water where marine growth is a problem, the use of anti-fouling paint may reduce the growth rate. Be aware of environmental regulations that may govern your paint choice. Contact your local boating authorities for information.

### **Cleaning Agents**

Household cleaners should be used sparingly and not discharged into waterways. Never mix cleaners and be sure to use plenty of ventilation in enclosed areas while

cleaning your boat. **DO NOT** use products which contain phosphates, chlorine, solvents, non-biodegradable or petroleum-based products. Refer to the *Care and Maintenance* section in this manual for more information.

### **MARPOL Treaty**

The USCG enforces the International Convention for the Prevention of Pollution from ships, commonly referred to as the MARPOL Treaty (Marine Pollution). This treaty prohibits the overboard dumping of all ship-generated plastics, chemicals, garbage and oil.



### **California Air Resource Board (CARB) Label**

The boat may have an environmental star label affixed on the bow port side of the boat as part of the California Air Resource Board (CARB) SD/I rule. This label must stay affixed to the boat if it is operated in California. The label confirms that the boat is equipped with a California Certified Engine. The label is positioned so it will be at the leading or trailing edge of the state registration numbers.

(More information about the star ratings system appears in the *Engine* section of this owner's manual.)



### **Proposition 65**

## **WARNING**

**A wide variety of components used on this vessel contain or emit chemicals known to the state of California to cause cancer, birth defects and other reproductive harm.**

#### **EXAMPLES INCLUDE:**

- **Engine and generator exhaust.**
- **Engine and generator fuel, and other liquids such as coolants and oil, especially used motor oil.**
- **Cooking fuels.**
- **Cleaners, paints and substances used for vessel repair.**
- **Waste materials that result from wear of vessel components.**
- **Lead from battery terminals and from other sources such as ballast or fishing sinkers.**

#### **TO AVOID HARM:**

- **Keep away from engine, generator and cooking fuel exhaust fumes.**
- **Wash areas thoroughly with soap and water after handling the substances above.**



# ON-PRODUCT WARNING LABELS

## Warning Labels & Locations

Warning labels are placed at specific locations on your Cobalt boat at the time of manufacture to alert you to potential hazards that may not be obvious. These labels also indicate how to avoid these hazards. Warning labels should never be removed and must remain legible. If you suspect a label is missing, or if a label becomes damaged or becomes unreadable (damaged, faded, or sun-bleached), contact your dealer for replacement.

It is the responsibility of the boat owner and occupants of the boat to understand and comply with all warning labels and safety recommendations/requirements. The driver of the boat and the boat owner are responsible for the proper operation of the boat and the safety of the occupants of the boat. Failure to adhere to and comply with the on-product warning labels and safety statements labeled as dangers, warnings, and cautions that appear in this manual can lead to serious injury, or death, as well as property damage. **READ AND ADHERE TO ALL WARNING PLATES AND LABELS** from bow to stern, including those that are installed inside the engine compartment, lockers, and underneath seating.



Helm (varies by model)

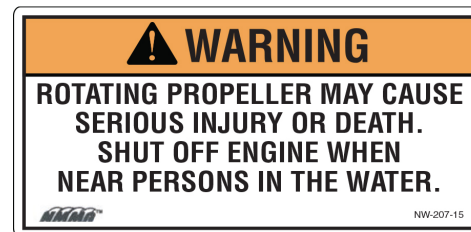

Helm

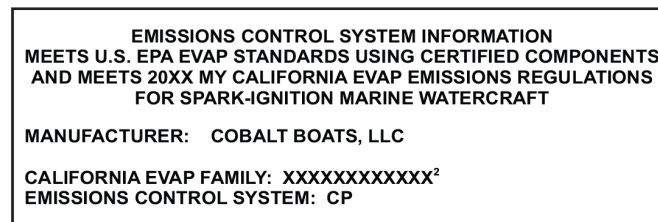

Helm

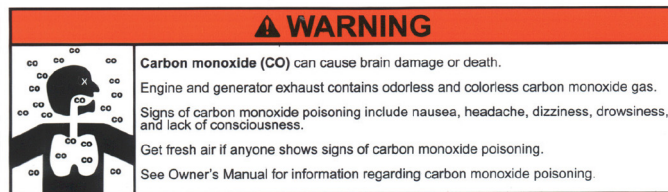

Located at Helm



Helm

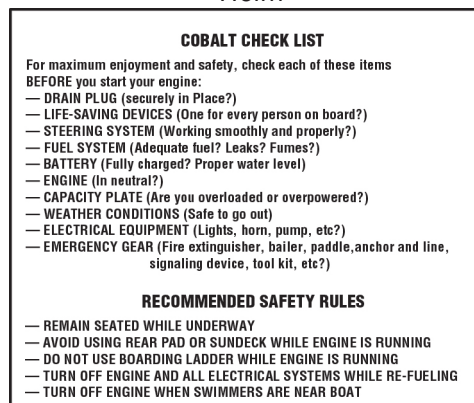

Helm

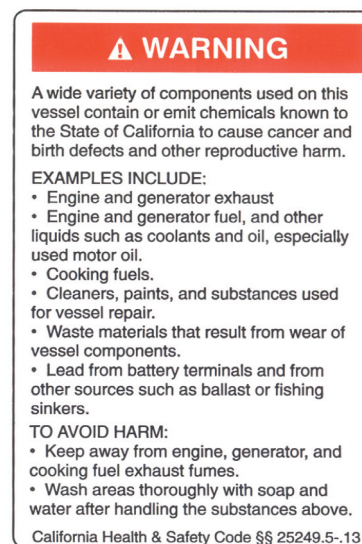

Helm (California Only)



Cockpit Area

**It is illegal for any vessel to dump plastic trash anywhere in the ocean or navigable waters of the United States. Annex V of the MARPOL TREATY is an**

**International Law for a cleaner, safer marine environment. Violation of these requirements may result in civil penalty up to \$25,000, fine and imprisonment.**

<p>U.S. Lakes, Rivers, Bays, Sounds and 3 miles from shore</p> <p><b>ILLEGAL TO DUMP Plastic &amp; Garbage</b></p> <p>Paper Rags Glass Food</p>	<p>3 to 12 miles</p> <p><b>ILLEGAL TO DUMP Plastic</b></p> <p>Dunnage, lining &amp; packing materials that float, also if not ground to less than one inch:</p> <p>Paper Rags Glass</p>	<p>12 to 25 miles</p> <p><b>ILLEGAL TO DUMP Plastic</b></p> <p>Dunnage, lining &amp; packing materials that float</p>	<p>Outside 25 miles</p> <p><b>ILLEGAL TO DUMP Plastic</b></p>
---	---	---	---

State and local regulations may further restrict the disposal of garbage.



*Storage Area*

**NOTE: ON OCCASION, YOU MAY HAVE TO CLEAR THE PILE OF ROPE FROM UNDER THE HAWSE PIPE TO MAKE ROOM FOR THE REMAINING ROPE.**

*Windlass, Where Applicable*

**ATTENTION**

WHEN USING SURF SYSTEM, TURN OFF POWER TRIM ASSIST (PTA) LOCATED ON CONTROL LEVER. PTA MAY CAUSE UNDESIRE SURF SYSTEM OPERATION

*Windshield Wing/Starboard Side*

**WARNING**

AVOID OBSTRUCTION OF NAVIGATION LIGHTS AND POSSIBLE COLLISION. REMOVE CANVAS BEFORE USING NAVIGATION OR ANCHOR LIGHTS.

*Navigation Light*

**WARNING**

**AVOID SERIOUS INJURY OR DEATH FROM FIRE, EXPLOSION OR ELECTRICAL SHOCK.**

- This device must be connected to a Ground Fault Circuit Interrupter (GFCI) Protected AC outlet.
- When using an extension cord, connect charger AC plug before connecting to the GFCI protected AC outlet.
- Make connection in an open atmosphere free of explosive fumes.
- Make connection in a secure manner that will avoid contact with water.

*Battery Charger*

**DISCHARGE OF OIL PROHIBITED**

THE FEDERAL WATER POLLUTION CONTROL ACT PROHIBITS THE DISCHARGE OF OIL OR WASTE INTO OR UPON THE NAVIGABLE WATER OF THE UNITED STATES OR THE WATERS OF THE CONTIGUOUS ZONE IF SUCH DISCHARGE CAUSES A FILM OR SHEEN UPON OR A DISCOLORATION OF THE SURFACE OF THE WATER OR CAUSE A SLUDGE OR EMULSION BENEATH THE SURFACE OF THE WATER VIOLATORS ARE SUBJECTED TO A PENALTY OF \$5000.

*Engine Compartment*

**WARNING**

**BIMINI AND ATTACHED ANCHOR LIGHT MUST BE INSTALLED FOR NIGHTTIME BOATING**

*Bimini*

**WARNING**

This tower is designed to tow a wakeboarder. Do not tow other boats, tubes, parasails, etc. Do not climb, jump or dive off the tower. Do not sit behind the tower where you could come in contact with the rope. Do not allow loose ropes to hang from the tower. Do not trailer the boat with boards or skis in the racks. Before and during each use make sure all bolts and fasteners are tight. Make sure you have sufficient clearance above the tower when it is up. Watch for bridges, power lines, tree limbs and other low hanging obstacles. Failure to follow these instructions can lead to serious injury or death.

*Eclipse Arch*

**WARNING**

**SKI TOW MAXIMUM LOAD - 1,000 POUNDS  
REMOVE TOW POLE BEFORE OPENING ENGINE HATCH**

*Ski Tow*

**WARNING**

**SUDDEN MOVEMENT OF BOAT CAN CAUSE LOSS OF BALANCE, FALL, OR EJECTION FROM BOAT.  
SEVERE OR FATAL INJURY MAY RESULT  
DO NOT OCCUPY THIS AREA WHILE THE BOAT IS UNDERWAY.**

*Sun Pad*

**DANGER**

**Carbon monoxide (CO) can cause brain damage or death.**

Engine and generator exhaust contains odorless and colorless carbon monoxide gas.

Carbon monoxide will be around the back of the boat when engines or generators are running.

Move to fresh air, if you feel nausea, headache, dizziness, or drowsiness.

NW-208-05

*Transom*

**WARNING**

**PROPELLER LOCATED BEHIND THIS BOAT. CONTACT MAY CAUSE SEVERE INJURY OR FATALITY. DO NOT APPROACH OR USE LADDER AND PLATFORM WHEN THE ENGINE IS RUNNING.**

*Transom*

**CAUTION**

**POTENTIAL DAMAGE**

**DAMAGE TO OUTDRIVE, PROPELLER, OR SWIM STEP CAN OCCUR. DO NOT DEPLOY SWIM STEP IF OUTDRIVE IS TRIMMED TO "TRAILER" POSITION. TRIM OUTDRIVE DOWN AND TURN ENGINE OFF PRIOR TO DEPLOYING STEP.**

*Swim Step Area*

# BASIC RULES OF THE ROAD

## Boating Regulations

The U.S. Coast Guard (USCG) is the governing authority of the United States waterways and serves to help the boating public. State boating regulations are enforced by local authorities. Owners and users outside of the United States must be cognizant of that country's laws and regulations. You are subject to marine traffic laws and nautical Rules of the Road for both federal and state waterways; you must stop if signaled to do so by enforcement officers and permit them to board if asked.

Review and understand all local, state, federal, and country boating laws.

Increasingly, governmental bodies are establishing new laws, rules and regulations regarding specific water activities. Because of the widespread interest in wakeboarding and wake surfing, the state in which you are wakeboarding/wake surfing may:

- Require operators to stay a specific distance from all shorelines, docks, piers or other structures. That means the channel or body of water will need to be of a defined width to be considered acceptable.
- Require riders engaging in towed watersports to wear a U.S. Coast Guard-approved life jacket.
- Prohibit wakeboarding/wake surfing during the hours between sunset and sunrise.
- Prohibit wake surfing behind a boat with an exposed propeller that extends beyond the boarding platform.
- Prohibit wakeboarding/wake surfing on small bodies of water, i.e., less than fifty (50) acres.

Even in areas not governed by similar laws, these kinds of requirements and limitations represent a common-sense approach to recreation.

There are many USCG pamphlets available to you. These pamphlets go beyond the contents of this manual and explain Rules of the Road, signal lights, buoys, safety, international and inland regulations. An example is *The Ultimate Watersports Handbook* you should have received with your new boat, or which can be ordered by contacting WSIA; go to: [www.WSIA.net](http://www.WSIA.net). For more information, contact your local USCG Unit or visit <http://www.uscgboating.org>.

You should be aware of these rules and follow them whenever you encounter another vessel on the water. The rules presented in this manual outline only the most basic of the nautical Rules of the Road and have been provided as a convenience only. Consult your local U.S. Coast Guard Auxiliary (USCGA), Department of Motor Vehicles (DMV) or local maritime authority for a complete set of rules governing the waters in which you will be using your boat. If you plan to travel—even for a short trip—you would be well-served to contact the regional USCGA or DMV in the area where you will be boating.

The nautical Rules of the Road must be followed to prevent collisions between vessels. Like traffic laws for automobiles, the operator is legally required to follow the rules.

### WARNING

**Collisions between boats can cause death or serious injury. Keep a proper lookout, safe speed, and follow the nautical Rules of the Road.**



## Encountering Another Vessel

Any time two vessels on the water meet one another, one vessel has the right-of-way. It is called the “stand-on” or “privileged vessel.” The vessel which does **NOT** have the right-of-way is called the “give-way” or “burdened vessel.” These rules determine which vessel has the right-of-way, and accordingly, what each vessel should do.



## Privileged Vessel

The privileged vessel has the right-of-way and has the duty to continue its course and speed, except to avoid an immediate collision. When you maintain your direction and speed, the other vessel will be able to determine how best to avoid you.

### NOTICE

**In general, boats with less maneuverability have right of way over more-agile crafts. You must stay clear of the vessel with right-of-way and pass to his stern.**

Sailboats and boats paddled or rowed have the right-of-way over motorboats. Sailboats under power are considered motorboats. Small pleasure craft must yield to large commercial boats in narrow channels.



## Burdened Vessel

The burdened vessel does not have the right-of-way and has the duty to take positive and timely action to stay out of the way of the privileged vessel. Normally, the burdened vessel should not cross in front of the privileged vessel. The burdened vessel should slow down or change directions and pass behind the other vessel. The burdened vessel operator should always move in such a way that the privileged vessel operator can see what you are doing in ample time to avoid a collision.



## Crossing

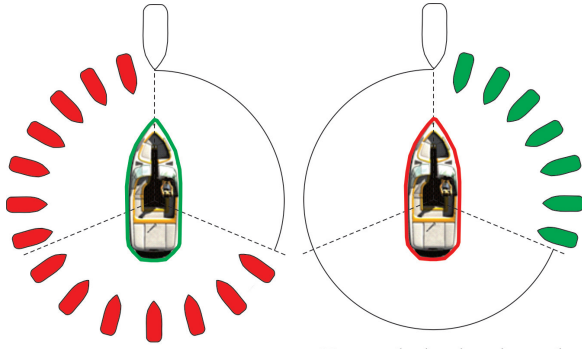

You are the privileged vessel.  
You must stand on.

You are the burdened vessel.  
You must give way.

In crossing situations, the boat to the right from the 12 o'clock to the 4 o'clock position has the right-of-way, and it must hold course and speed. The burdened boat passes behind the privileged boat. Boats going up and down a river have the privilege over boats crossing the river. The illustration depicts a situation in which you are the boat in the center, and you are the privileged vessel. You must hold course and speed. All vessels approaching your vessel from the directions depicted by the red vessels must yield to your boat.

Conversely, the illustration depicts a situation in which you are the boat in the center, and you are the burdened vessel. You must give right-of-way to all vessels coming towards you from the directions shown in green.



## Meeting Head-On

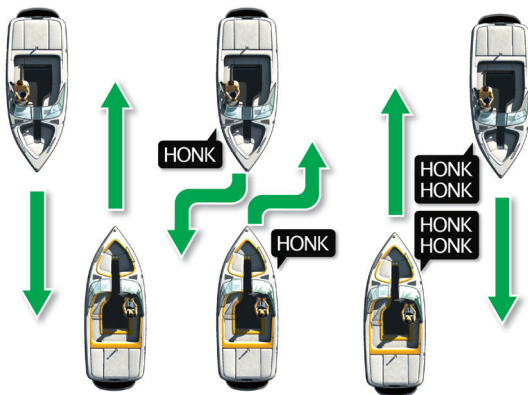

When meeting head-on, neither vessel has the right-of-way. Both boats should decrease speed, turn towards their right (starboard side) and pass on their left sides (port-to-port). However, if both boats are clearly on each other's right (starboard) side then, each vessel should sound two short blasts and pass on their right sides (starboard-to-starboard).



## Overtaking

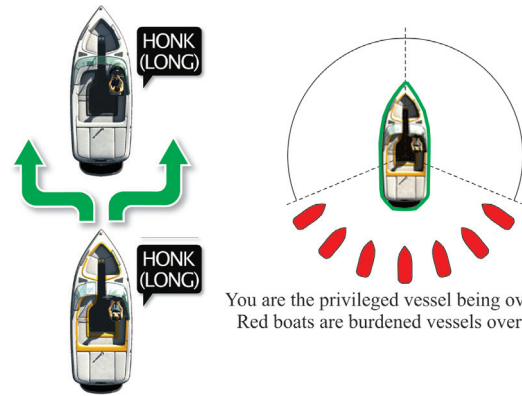

You are the privileged vessel being overtaken.  
Red boats are burdened vessels overtaking.

The boat that is overtaking one ahead of it is the burdened boat and must make any adjustments necessary to keep out of the way of the privileged boat, until the burdened boat is well ahead and clear of the vessel being overtaken.



## The General Prudential Rule

The General Prudential Rule regarding right-of-way, is that if a collision appears unavoidable, neither boat has right-of-way. As prescribed in the Rules of the Road, both boats must act to avoid collision.

**Rule 2 in the International Rules says, "In construing and complying with these Rules due regard shall be had to all dangers of navigation and collision and to any special circumstances, including the limitations of the vessels involved, which may make a departure from these Rules necessary to avoid immediate danger."**



## Other Rules of the Road

When navigating in narrow channels, you should keep to the right when it is safe and practical to do so. If the operator of a power-driven vessel is preparing to go around a bend that may obstruct the view of other water vessels, the operator should sound a prolonged blast on the whistle or horn—four (4) to six (6) seconds.

If another vessel is around the bend, it too should sound the whistle or horn. Even if no reply is heard, however, the vessel should still proceed around the bend with caution.

If you navigate this type of waters, you should carry a portable air horn, which is available from local marine supply stores.





## Aids to Navigation

Learn to recognize the different buoys and day markers; they are the signposts of the waterways. The United States Aids to Navigation System (US-ATONS) is the primary marking system used on inland waters, coastal waters and rivers in the United States. This system is maintained by the U.S. Coast Guard (USCG).

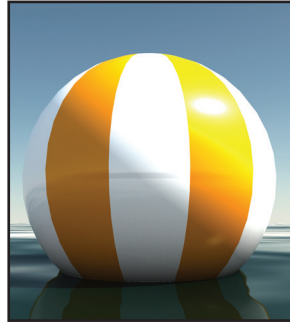

Spherical Safe Water Marker

There are two primary marking systems in use in the U.S.: the Uniform State Waterway Marking System (USWMS), used on inland waters and maintained by each state, and the Federal Waterway Marking System (FWMS), used on coastal waters and rivers and maintained by the USCG. In addition, the FWMS has two modified systems: the Western River Buoyage, and the Intracoastal Waterway Buoyage. Be sure to check with local authorities on the buoyage system in use in your boating region.

The type of hazard/warning buoys and markers depends on the area of jurisdiction. Check with local boating authorities.

### USWMS System

In the USWMS Lateral System, well-defined channels are marked with red and black buoys, and the boat should pass between them.

The USWMS Cardinal System is used when there is no well-defined channel or where an obstruction may be approached from more than one direction. With the cardinal system:

- Pass north or east of **BLACK-TOPPED WHITE** buoy.
- Pass south or west of **RED-TOPPED WHITE** buoy.
- **RED and WHITE VERTICALLY STRIPED** buoy indicates boat should pass outside of the buoy (away from shore).

### FWMS System

The FWMS Lateral System is for use on navigable waters except Western Rivers and Intracoastal Waterways. The markings on these buoys are oriented from the perspective of being entered from seaward (the boater is going toward the port). This means that red buoys are passed on the starboard (right) side of the vessel when proceeding from open water into port, and green buoys to the port (left) side.

The right side (starboard) of the channel is marked with **RED**, even numbered buoys.

The left (port) side of the channel is marked with **GREEN**, odd numbered buoys.

The middle of the channel is marked with **RED** and **WHITE** vertically striped buoys; pass close to these buoys.

Obstructions, channel junctions, etc. are marked with **RED** and **GREEN** horizontally striped buoys.

A **RED** band at the top means the preferred channel is to the left of the buoy; a **GREEN** top band means the preferred channel is to the right of the buoy.

Day markers are colored and numbered the same as buoys. **RED**, triangular day markers with even numbers mark the starboard side of the channel. **GREEN**, square day markers with odd numbers mark the port side of the channel.

Lights, bells and horns are used on buoys for night or poor visibility conditions. Buoys with unique light flashing characteristics are identified on nautical charts with the specific flashing pattern.

### Types of Buoys

There are several types and shapes of buoys. Buoys may be unlighted, lighted, with sound or may have both an audible and a visual signal. Lights, bells and horns are used on buoys for night or poor visibility conditions. Different shapes of buoys are shown following.

Buoys with unique light flashing characteristics are identified on nautical charts with the specific flashing pattern.

### Mooring Buoys

The only buoys from which you are permitted to moor are mooring buoys. Mooring buoys are white with a blue horizontal stripe. Mooring to a navigation buoy, regulatory markers or lateral markers is illegal.

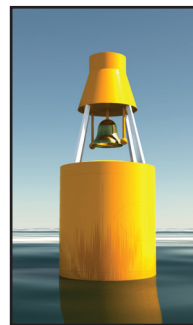

UNLIGHTED BELL BUOY



SPAR BUOY

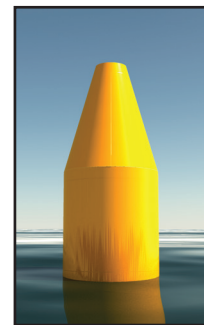

NUN BUOY

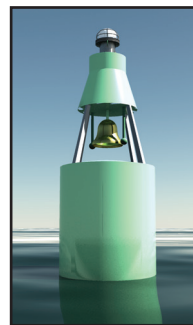

LIGHTED BUOY

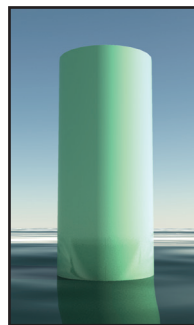

CAN BUOY

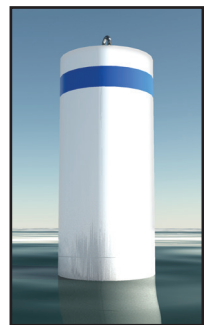

MOORING BUOY



### Uniform State Regulatory Markers

Regulatory markers indicate dangerous or restricted controlled areas. These markers are used to indicate speed zones, areas set aside for particular use, general information and directions.

Regulatory markers are white with orange geometric shapes and also have orange bands near the top and at the water line of the buoy. You must obey regulatory markers.

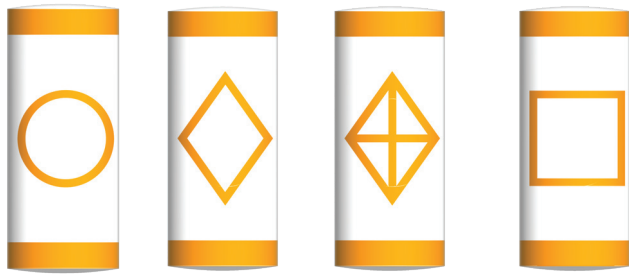

CONTROLLED AREA    DANGER    BOATS KEEP OUT    INFORMATION

### Uniform State Waterway Marking System (USWMS)

**THERE ARE OTHER SYSTEMS OF MARKERS. IT IS THE RESPONSIBILITY OF THE BOAT OPERATOR TO DETERMINE WHICH MARKING SYSTEM IS IN USE IN THE BODY OF WATER IN WHICH THE OUTING WILL OCCUR. UNDERSTAND AND ABIDE BY ALL MARKING SYSTEMS.**



#### Diver's Flag

Used by recreational divers—indicates position. Stay far away from diver flags. Someone is underwater in the vicinity.

#### Alpha Flag

Worldwide vessels engaged in diving operations—does not indicate diver's position.



#### Distress Flag

Indicates fellow boater is in need of assistance.

### Warning Markers

It is a good idea to ask local authorities if there are hazardous areas and how they are marked. Boaters must also recognize the flag designs, which indicate that skin divers are present and keep well clear of the area. Divers underwater cannot be seen. Stay well away from boats or floats displaying Diver Flags.



Skin Diver Warning



Swim Area Warning

Watch for swimmers. Swimming areas may not be marked. Steer clear from the area and remain alert.

Navigation markers serve as a means of identifying navigable routes and indicate water hazards. Boaters should become familiar with navigation markers and stay within marked boundaries and clear of hazards.



### Night Running

Operation of your Cobalt boat between sunset and sunrise in some locations may be restricted or not allowed at all. It is the responsibility of boat owners and boat operators to verify the laws, rules and regulations regarding nighttime operation for the body of water upon which you are running.

Boats operating between sunset and sunrise (hours vary by state) must use navigational lights. Nighttime operation, especially during bad weather or fog can be dangerous. All Rules of the Road apply at night, but it is best to slow down and stay clear of all boats, regardless of who has right-of-way. Protect your night vision by avoiding bright lights and have a passenger, if possible, help keep watch for other boats, water hazards and aids to navigation. It is best to proceed slowly at night, as there is always the possibility of unlit boats, floating objects, and fixed objects which will be very difficult to see in time to avoid if you are at planing speeds or above.

There are many light patterns on different types of boats and for boats performing various functions while underway or at anchor. For most applications on recreational boats the following navigation light patterns are applicable.

*(NOTE: Information is included here that does not apply to Cobalt boats. However, the information is included to assist Cobalt operators in being aware of the navigational lights that may appear on other vessels you may encounter.)*

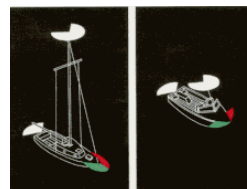
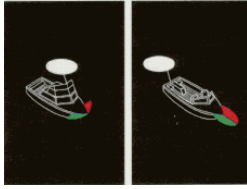

Figure 1

Motorboats less than 20 meters (65.62 feet) shall exhibit navigation lights as shown in Figure 1. (Note: Two masthead lights are optional for boats under 50 meters. Boats over 50 meters [164 feet] will display two masthead lights.)

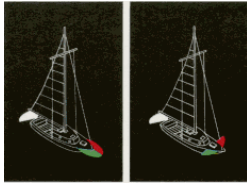



**Figure 2**

Motorboats of less than 12 meters (39 feet, 4 inches) in length, may show the lights in either Figure 1 or Figure 2. Boats of less than 7 meters (23 feet) whose maximum speed cannot exceed seven (7)

knots may exhibit an all-around white light, and, if practicable, sidelights instead of the lights prescribed above, in international waters only.



**Figure 3**

Sailboats and watercraft under oars: Sailboats less than 20 meters (65.62 feet) may exhibit the navigation lights shown in Figures 3 or 4.

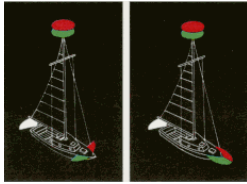
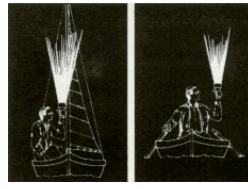

**Figure 4**



**Figure 5**

Another option for sailboats is to use a single combination lantern at the top of the mast as shown in Figure 5.



**Figure 6**

Sailboats less than 7 meters (22.96 feet) may carry an electric torch or lighted lantern showing a white light to be displayed in sufficient time to prevent collision (see Figure 6). If practicable the lights

prescribed for sailboats less than 20 meters should be displayed. Watercraft under oars (such as a canoe) may display the lights prescribed for sailboats, but if not, must have ready at hand an electric torch or lighted lantern (flashlight) showing a white light to be displayed in sufficient time to prevent collision (see Figure 6).

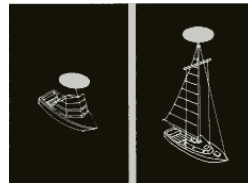

**Figure 7**

Anchored boats: Motorboats and sailboats at anchor must display anchor lights. An anchor light for a watercraft less than 50 meters (164 feet) in length is an all-around white light, visible for two (2)

miles exhibited where it can best be seen (see Figure 7).

Sailboats operating under machinery, or under sail and machinery, are considered power-driven and must display the lights prescribed for a power-driven boat.

## WATERSPORTS SAFETY

Skiers or riders are obligated to be aware of the same fundamental safety rules as boat operators. If you are new to water skiing, wakeboarding, wake surfing, and other towed watersports, seek certified training before starting. You will find it especially helpful to join a local ski club, World Wakeboard Association, and/or USA Water Ski, when possible.

Always remember that the majority of injuries occurring while water skiing/wakeboarding and other towed watersports are the result of impacts with other objects. Always look where you are going and be aware of what is going on around you.

When participating in towing watersports, be safe and courteous and follow these guidelines:

- Be considerate to fishermen and others who are sharing the same body of water.
- **DO NOT** perform watersports in congested areas.
- Stay away from navigation markers.
- Stay away from other boats and watersports participants.

### DANGER

**Contact with a spinning propeller can cause injury and death. Do not enter or exit the water when the engine is running (ON) and the propeller spinning. DO NOT get on the swim platform when the engine is running. DO NOT swim towards the back of the boat if the engine is on.**

### WARNING

**Failure to adhere to these warnings may result in severe injury or death to you and/or others.**

- Every towed person must always wear a USCG-approved personal flotation device.
- Always have an experienced driver and a designated observer in the boat while being towed.
- Maintain a distance of at least 100 feet from all other objects, including other boats, piers, rafts, mooring and navigational buoys, pilings, abutments, or any other items.

- Never water ski, wakeboard or participate in other towed watersports in shallow water, close to shore, or in water where you do not know the depth or what is beneath the surface.
- Never put your arm, head, or any other part of your body through the handle-bridle of the tow line nor wrap the line around any part of the body at any time.
- **DO NOT** participate in watersports while under the influence of alcohol and/or drugs.
- **DO NOT** participate in watersports during inclement weather or on rough water.
- Never water ski, wakeboard or participate in other towed watersports directly in front of other boats who may run over you if you fall.
- Never water ski, wakeboard or participate in other towed watersports at night.
- Never jump from a boat that is moving at any speed.
- Make sure that everyone knows and uses approved towed watersports hand signals.



## Hand Signals

Make sure that everyone knows and uses approved towed watersports hand signals, as shown.



CIRCLE



BACK TO DOCK



CUT ENGINE



SKIER IN WATER



SKIER OK



SPEED OK



STOP



SPEED FASTER



SPEED SLOWER



TURN LEFT



TURN RIGHT



## Towed Person Safety Responsibilities

Most injuries and fatalities that occur on high-performance recreational tow boats occur to the persons being towed (water skiing, knee-boarding, wakeboarding, wake surfing, tubing, etc.). It is the responsibility of the boat operator to pay attention to a multitude of things while utilizing the boat for water tow sports. The towed person has little or no control over their path nor do they have much in the way of protection from impact with obstacles or other boats. Therefore, it is recommended that boat operators, observers, and towed persons communicate effectively and clearly as to their intentions and their surroundings. The main responsibilities for each participant are as follow:

### *Operators should:*

- Assign a passenger to be a designated observer.
- Turn the engine(s) off whenever a person is on the swim platform or in the water near the boat. This is especially important for the area near the back of the boat to avoid propeller injuries.
- Ensure that it is “all clear” behind the boat when starting the engine(s). Ask for verbal confirmation or hand signals that it is “all clear” behind the boat. Then, and only then, start the engine(s).
- Keep their main focus on maneuvering the boat safely while avoiding other boats, fixed objects, the shore, and shallow water.
- Use rear view mirrors to allow the driver to glance at the towed person, while still keeping their main attention on the path of the boat and the surroundings.
- Return safely to pick up towed persons or persons in the water. Keep the individual in view, approach slowly (preferably on the driver’s side), and shut off the engine(s) when close to an individual in the water. **DO NOT** back up or operate the boat in reverse to a person in the water.

### *Observers should:*

- Confirm for the boat operator that it is “all clear” behind the boat prior to starting the engine.
- Watch the towed person.
- Be responsible for communication of the signals and status of the towed person to the boat driver.
- Notify the boat operator of status and changing conditions with the towed person and inform the boat driver of the towed person’s readiness to start, their desire to go faster or slower, or that they have fallen and are in need of retrieval.
- Deploy the fallen skier flag when the towed person falls, if needed. In some states, it is required to raise the “fallen skier” flag when the skier has fallen.
- Monitor the tow line to ensure that it does not become tangled, it does not become wrapped around



anyone in the boat, and it does not become wrapped around the towed person. Also monitor the tow line so that it does not become tangled in the propeller. Notify the boat operator if any of these conditions are observed to avoid potential injury.

- Remind the boat operator to shut off the engine(s) when persons are on the swim platform or in the water near the back of the boat.

*Towed persons should:*

- Wear a PFD.
- Not approach the back of the boat if the engine(s) is running.
- Not become entangled in a tow line or wrap a tow line around any body part.
- Know signals to communicate with the observer and boat operator.



### Additional Precautions for Towed Skier/Rider

- Wear wet suits or protective shorts when engaging in high energy skiing/riding to prevent abrasions, hypothermia, and injuries to orifices (rectal and vaginal) from impact with the water surface.
- Inspect watersports equipment for wear, fraying, etc., before use. **DO NOT** use if they show signs of wear or fraying. Ropes or watersport equipment tow points may break during use, causing you to coast into obstacles or fall with the risk of being struck by another vessel.
- Inspect the boat tow points before use. If there is any evidence of corrosion or other damage, do not use until it has been inspected by your authorized Cobalt Boat dealer.
- **NEVER** attach ski/wakeboard rope to anything but approved pylons and wakeboard towers. Make sure tow ropes are properly attached to the boat tow points.
- The skier/rider should verbally indicate that (s)he is safely clear of the boat prior to operator starting the boat engine or putting the boat into gear.
- Slowly take up slack in tow lines before accelerating to watersports speeds. Jerking the slack out of a tow line can cause high forces on the rope and towing equipment. This may cause the rope or equipment to break and the rope to snap back at occupants of your boat and at the towed person.
- Never put your arm, head or any other part of your body through the handle/bridle of the ski or wakeboarding line, nor wrap the line around any part of the body at any time. If you fall, the line will tighten and forcefully constrict around your body part and may result in amputation.



- **DO NOT** ski near swimming areas, beaches, personal watercraft, or other vessels/boats.
- Never attempt land or dock starts. These activities will increase your risk of injury or death.
- **DO NOT** jump from a boat that is moving at any speed, nor enter or exit the water when the engine is running.
- **DO NOT** “back up” to anyone in the water; they will be in danger of hitting the spinning propeller which can cause severe injury or death.
- **DO NOT** follow directly behind another boat or skier/rider without leaving an adequate safe distance in case that towed person falls into the water. You will need ample time and distance to maneuver your boat away from that person in the water and to avoid their tow boat which will be circling back to retrieve their downed person.
- **DO NOT** participate in towed watersports at night. It is illegal and other boats will not be able to see you, nor will they anticipate or expect your presence behind the towing boat. Furthermore, once you fall, they will not see you swimming.
- **DO NOT** tow with multiple skier/riders with different length ropes.
- **DO NOT** ski in limited visibility conditions.
- Never climb, sit or stand on a wakeboard tower. The wakeboard tower is intended for towing only as noted. It is designed to pull a limited number of individual(s), and in some cases only one (1) individual. Please consult the remainder of this owner’s manual and warning labels on the tower for details. The wakeboard tower approved for use on your boat should be used only for water skis, wakeboards or recreational towables, and not for parasailing, kite flying or towing other boats.
- Many states require the use of “skier down” flags. Check your local lake and state requirements. Having the observer raise a skier down flag when your towed watersport participant falls down or off the towed device will alert boats around you to the fact that someone is in the water nearby and that they should avoid the area.
- Many lakes have recommended tow patterns. Other boats may expect that you know the local customs and practices. It is common that the tow pattern is counter-clockwise around the lake, but there are exceptions. Check for local recommendations or requirements.
- **NEVER** lift or trailer the boat with water in the bilge or in ballast tanks. Lift or trailer per manufacturer’s instructions.
- Around marina docks where electrical current is present (such as shore power connections) it is unsafe to swim as stray electrical currents may exist, which can cause you to drown.



## Tow Line Guidelines

Tow lines come in different lengths and strengths for different activities. Make sure any line you are using is suited for skiing or riding and that it is in good condition.

- Never use a tow line that is frayed, knotted, unraveling or discolored from use or being left in the sun. If a line breaks while in use it can recoil at the skier/ rider being towed or into the watercraft where it might strike passengers. Replace tow lines with any sign of damage.
- Never use a tow line with elastic or bungee material to pull skiers or riders.
- Tow line should be attached to the watercraft in an approved fashion with hardware designed for towing. Refer to your watercraft manual for instructions on proper tow line attachment.
- Always route tow lines away from the propeller, even when idling. Shut off the engine if your boat starts to cross a floating tow line.
- If a tow line should become entangled in a propeller, shut off engine, remove the key and put it in your pocket before retrieving the line.
- Tow lines should be neatly coiled and stowed in the boat when not in use.



## Fallen Skier or Rider

Falling and injuries are common in water skiing and other towed watersports. Keep tow speeds in a comfortable range given the rules of the activity and the skill level of participants.

- Display a red or orange skier/rider down flag to alert other vessels that a skier/rider is down. In some states, it is required to raise the “fallen skier” flag when the skier has fallen.
- Turn the boat and slowly circle toward the person in the water to return the tow line handle or towed device to that person.
- Always keep the fallen skier/rider in view and preferably on the operator’s side of the watercraft.
- Put the watercraft in neutral whenever you are near a fallen skier/rider.
- Shut off the engine when retrieving someone from the water or if the person in the water gets too close to the boat. Do not trust neutral gear with an idling engine. Someone may accidentally or prematurely shift the gear, or the linkages may be out of adjustment and the propeller may still be slowly spinning.



## Develop WATER SENSE

The Watersports Responsibility Code and the Watersports Safety Code have been developed by WSIA and industry equipment manufacturers. These Codes are reproduced here for your reference.

### WATERSPORTS SAFETY CODE

Before you get in the water: Skiing or riding instruction is recommended before use. Instruction will teach general safety guidelines and proper skiing or riding techniques, which may reduce your risk of injury. For more information on skiing or riding schools, contact your dealer, association, or local ski club.

- Know the federal, state and local laws that apply to your area.
- If you are not familiar with a waterway, ask someone who is knowledgeable to tell you about any hidden dangers or things to avoid.
- Whether you plan to be in a watercraft, or skiing/riding behind one it is important you are wearing a properly fitted life jacket (PFD) approved by your country’s agency, USCG Type III, ISO, etc.
- Inspect all equipment prior to each use, check bindings, fins, tube, attachment, tow rope and flotation device. **DO NOT** use if damaged.

**Watercraft Safety:** A knowledgeable and responsible driver is the most important safety device on any watercraft.

- Never operate a watercraft, ski or ride under the influence of alcohol or drugs.
- Use only water ballast and people for additional weight.
- Never exceed the passenger or weight limitations of the watercraft.
- Never allow passengers to hang outside the watercraft or towed device or sit on the gunwales or anywhere outside of the normal seating area.
- Never allow water to overflow the bow or gunwales of the watercraft.
- Uneven weight distribution or additional weight may affect the handling of the watercraft.

**Carbon Monoxide:** The exhaust from the engine on a watercraft contains Carbon Monoxide (CO) which is a colorless, odorless and poisonous gas. Excessive exposure to CO can cause severe injury or death. Follow this advice to avoid injury.

- Never “Platform Drag” by holding onto the boarding platform or being dragged directly behind the watercraft. This is where CO will be.
- **DO NOT** sit on the watercraft transom or the boarding platform while the engine is running.



**water, and do not use the swim platform when engines are running. Carbon monoxide poisoning should not be confused with seasickness, intoxication or heat stress. If someone complains of irritated eyes, headache, nausea, weakness or dizziness, or if carbon monoxide is suspected, immediately move the complainant to fresh air, investigate the cause and take correction action. Seek medical attention when necessary.**

**Tow Ropes:** Tow ropes come in different lengths and strengths for different activities. Make sure any rope you are using is suited for that activity and that it is in good condition.

- Make sure the engine is properly tuned and running well. An improperly tuned engine produces excessive exhaust and CO.
- If you smell engine exhaust do not stay in that position.
- Go to the United States Coast Guard’s website: ([www.uscgboating.org](http://www.uscgboating.org)) for more information on how to help protect yourself and others from the dangers of CO.

- Never use a rope that is frayed, knotted, unraveling or discolored from use or being left in the sun. If a rope breaks while in use it can recoil at the skier/rider being towed or into the watercraft where it might strike passengers. Replace tow ropes with any sign of damage.
- Never use a tow rope with elastic or bungee material to pull skiers or riders.
- Rope should be attached to the watercraft in an approved fashion with hardware designed for towing. Refer to your watercraft manual for instructions on proper tow rope attachment.
- Always keep people and tow ropes away from the propeller, even when idling.
- If a tow rope should become entangled in a propeller, shut off the engine, remove the key and secure it in a safe location before retrieving the rope.
- Tow ropes should be neatly stowed in the boat when not in use.



## Platform Dragging (“Teak Surfing”)

**READ, KNOW** and **UNDERSTAND** the information on warning labels and adhere to the boat operation practices described on them. The USCG issued a **SAFETY ALERT** on August 28, 2001, which covers some issues regarding improper use of the boarding ladder/swim platform. The **SAFETY ALERT** and portions of the information follow:

Tragic deaths occur from the negligence of unsafe boating and dangerous activities. Experts say, “Many of these deaths may have been caused by an invisible hazard, carbon monoxide poisoning.”

Taking the risk of swimming under a boarding platform when the engine is running, skiing within 20 ft (6.1m), or “teak surfing” or “dragging” behind a moving boat, and be fatal. Dangerous activities which can result in serious injury or death are not considered water sports.

Cobalt Boats does not promote unsafe boating risks or jeopardizing any boat’s safety. Teak surfing or platform dragging may be illegal in the state in which the boat is operated.



**DO NOT use the swim platform for any other purpose than boarding the boat or preparation for entering the**

**Preparing to Ski or Ride:** Always have a person other than the driver act as an observer to look out for the skier/rider.

- Be sure the driver is aware of the experience and ability of the skier/rider.
- The driver, observer and skier/rider need to agree on hand signals before skiing or riding. Signals should include **READY, STOP, SPEED UP** and **SLOW DOWN**.
- Start the engine only after making sure that no one in the water is near the propeller.
- Turn the engine off when people are getting into or out of the watercraft, or in the water near the watercraft.
- Always make sure the tow rope is not wrapped around



- anyone's hands, arms, legs or other parts of the body.
- Start the watercraft and move slowly to remove slack until the tow rope is tight.
  - When the skier/rider signals **READY** and there is no traffic ahead, take off in a straight line. Adjust the speed according to the signals given by the skier/rider.

**Skiing or Riding:** The watercraft and skier/rider should always maintain a sufficient distance from obstacles so a skier/rider falling or coasting and/or watercraft will not encounter any obstacle.

- Do not use in shallow water or near shore, docks, pilings, swimmers, other watercraft, or any other obstacles.
- Use only on water.
- Never attempt land or dock starts. This will increase your risk of injury or death.
- Always wear a properly fitted life jacket (PFD) approved by your country's agency, USCG Type III, ISO, etc.
- The faster you ski or ride, the greater your risk of injury.
- Never make sharp turns that may cause a slingshot

effect on the skier/rider's speed.

- The skier/rider should be towed at an appropriate speed for his or her ability level.

**Fallen Skier or Rider:** Falling and injuries are common in skiing or riding.

- Circle a fallen skier/rider slowly to return the tow rope handle or pick up the fallen skier/rider.
- Turn off the engine when near a fallen skier/rider.
- Always keep the fallen skier/rider in view and on the driver's side of the watercraft.
- Display a red or orange skier-down flag to alert other vessels that a skier/rider is down if required by the state in which you are operating.

**The Warnings and practices in the Watersports Safety Code represent common risks encountered by users. The code does not cover all instances of risk or danger. Please use common sense and good judgment.**

## EMERGENCY PROCEDURES

In an emergency situation, you may have to resort to measures which are not commonly practiced. Always assess the dangers of being in harm's way versus the protection of equipment. Keep a sound mind during an emergency and always use common sense.

### Explosion and Fire

Many boat fires and explosions involve flammable liquids such as gas or oil, which are used in your boat's propulsion engine(s) and generator. Carefully follow all warning labels and safety precautions while handling flammable substances. Many fires in inboard boats start in the bilge area due to gasoline vapors. Gasoline vapors are heavier than air and collect in the bilge of boats.



### Explosion

- If explosion is imminent, put on PFDs, grab distress signals and survival gear, and immediately abandon ship.



### Fire

- Immediately turn off engines, generators, stoves and blowers.
- Extinguish smoking materials.
- A fixed fire suppression system, if equipped, has heat

sensors that automatically flood the machinery space with a fire extinguishant. Allow extinguishant to "soak" the compartment for at least 15 minutes to cool the hot metals or fuel before cautiously inspecting the fire area. Have portable fire extinguishers ready. **DO NOT** breathe fumes or vapors caused by the fire or extinguishant.

- If no fixed fire suppression system is installed and a fire is in the engine compartment, discharge portable fire extinguishers through the engine compartment access plate, if equipped. **DO NOT** open the engine hatch as this feeds oxygen to the fire.
- If you have access to the fire, direct the contents of the fire extinguishers at the base of flames, not at the top.
- Throw burning materials overboard if possible.
- Move anyone not needed for firefighting operations away from the flames.
- Signal for help.
- Put on PFDs (Personal Flotation Devices), grab distress signals and survival gear, and prepare to abandon ship.



**WARNING**

**Burn hazard from gasoline floating on water which is ignited can cause death or serious injury. Gasoline will float on top of water and can burn. If the boat is abandoned, swim upwind, far enough to avoid fuel that can spread over the surface of the water.**





## Swamping and Flooding

In the event that the vessel begins to take on water, turn on the bilge pump to evacuate water and slow its accumulation, and try to determine the source of the water. A collision with an underwater object can cause the hull to develop a leak. A loose-fitting hose clamp on a piece of equipment can cause a leak. Try to repair the leak if possible. If a leak is threatening the safety of you and your passengers, call or signal for assistance.

- Turn on bilge pump(s).
- Access PFDs, pass them out to everyone, and put them on.
- Identify source of leak and try to stop the leak and flooding.
- **STAY WITH THE BOAT!** A boat will usually float even if there is major hull damage. Rescuers can spot a boat much easier than a head bobbing in the water.
- Signal or call for help.
- If others were on board, try to locate them, make sure that they are conscious and that they can swim.
- Immersion in water speeds the loss of body heat and can lead to hypothermia (the abnormal lowering of internal body temperature).



## Capsizing

- If others were on board, try to locate them, make sure that they are conscious and they can swim.
- If possible, access life jackets (PFDs), pass them out to everyone, and put them on.
- **STAY WITH THE BOAT!** A boat will usually float even if there is major hull damage. Rescuers can spot a boat much easier than a head bobbing in the water.
- Signal or call for help.
- Immersion in water speeds the loss of body heat and can lead to hypothermia (the abnormal lowering of internal body temperature).



## Staying Afloat

- Remain calm. Do not thrash about or try to remove clothing or footwear. This leads to exhaustion and increases the loss of air that may keep you afloat.
- Keep your life jacket (PFD) on.
- Keep your knees bent.
- Float on your back and paddle slowly to safety.



## Collisions

- Immediately account for all passengers.
- Check for injuries.
- If any person is in the water, make sure they have proper flotation devices.
- Assess the hull for damage.
- Activate the bilge pump(s) to reduce any flooding.
- Try to operate the boat to keep the damaged area above water.
- If necessary, call or signal for assistance.
- **STAY WITH THE BOAT!**



## Grounding

In the event you run aground, assess the situation before proceeding. Your response to grounding will depend on how hard the boat hits bottom and whether the boat remains stranded, the extent of damage, and proximity to shore and help.

- If it is a simple touch, you may need only to inspect the hull.
- If you are aground, assess the situation before reacting. In some cases, throwing the boat into reverse can cause more damage.
- Check for leaks and immediately stop any water from entering the boat.
- Inspect the hull, steering system and propulsion system for damage.
- Maneuver the boat to safe water only if the hull and all operating systems are in satisfactory operating condition. Otherwise, call or signal for assistance.



## Person Overboard

- Immediately react to a person who has fallen overboard by sounding an alarm.
- Keep the victim constantly in your sight.
- If another passenger is on board, assign them to look at and keep pointing at the person in the water. They are to do nothing else but stay focused on the person in the water and to point at them.
- Throw the person a life preserver even if they are wearing a PFD. It will serve as a marker in the water and will provide additional flotation.
- Immediately slow or stop the boat and safely circle toward the victim as soon as possible.
- Keep the victim on the helm side of the vessel so as to keep the victim constantly in your sight.
- When almost alongside, shut off the engine.
- Assist the person into the boat.



## Unassisted Means of Reboarding

To reboard a boat:

- Move to the swim platform on the transom of the boat.
- Place both hands, palms down, onto the top of the platform.
- Using your legs to kick upwards, pull your body and legs up over the edge of the swim platform.
- Use the grab handles that are mounted to the transom of the boat to gain additional leverage.
- Lean into the swim platform and swing one leg up onto the swim platform. Then use the grab handle to provide support while pulling the rest of your body onto the swim platform.
- Stand up and maintain three points of contact with the boat. Use the transom step to climb back into the boat.



**Be aware that there are metal surfaces mounted on the hull beneath the swim platform. Do not allow arms, legs, or body parts to extend before the swim platform as these surfaces may cause minor-to-moderate injuries.**



## Drowning

- Swim to rescue a drowning victim only as a last resort.
- **Immediate resuscitation is critical!** It may be possible to revive a drowning victim who has been under water for some time and shows no sign of life. Start CPR immediately and get the victim to a hospital as quickly as possible.
- Keep the victim warm.
- Use care in handling. Spinal injury may exist if the victim fell overboard.
- Call and signal for help.



## Medical Emergency

In an emergency, you may be far from professional medical assistance. Be prepared and know how to use your first aid kit. Be aware of any special medical conditions of your passengers.



## Operation Failure

If you experience a propulsion, electrical, steering or control failure, immediately shut off the engine(s). If it is safe to do so and you are qualified, then try to determine the cause of the failure and repair. Otherwise, call or signal for assistance. Anchor the boat if drifting will put you and others in danger.



**Towing or being towed stresses the boats, hardware and lines. Failure of any part can seriously injure people or damage the boat.**



## Towing

A recreational boat towing another should be a last resort due to the potential for damaging one or both boats. The Coast Guard or a private salvage company is better equipped for this activity. A recreational boat may assist by standing by, and possibly by keeping the disabled boat's bow at a proper angle until help arrives. Only when conditions are ideal—that is, waters are calm, disabled boat is small, appropriate hardware is available, and one or both skippers know the correct technique—should a recreational boat tow another.

### Towing Vessel

- Be sure your boat will not run aground, too.
- Because you are maneuverable and the grounded boat is not, you should pass the towline to the grounded boat.
- Select an appropriately strong tow line. Use



double-braided or braid-on-braid line. Never use three-strand twisted nylon; it has too much elasticity and can snap back dangerously.

- Select an appropriate attachment point. If available, fasten the towline to the forward tow pylon of the towing boat. Otherwise fasten a tow line to a stern tow point. Fastening to the stern tow point will restrict maneuverability of the towing boat.
- If possible, use a bridle.
- Move slowly to prevent sudden strain on a slack line.
- Proceed at slow speed.
- Avoid abrupt changes in throttle as that may cause the tow line to slacken and jerk tight. Sudden strain or jerking the line causes excessive tow line forces which may part the line. Keep slack out of the tow line, but if it occurs proceed slowly to again take up the strain on the line and avoid sudden jerks in the line.

- Be ready to cast loose or cut the line if the towing situation becomes hazardous.

#### **Vessel Being Towed**

- Attach the towline to the bow eye.
- If it is necessary to be towed after being freed, keep someone at the wheel to steer.

#### **Both Vessels**

- If you attach the tow line to a fitting, be sure the fitting is fastened with a through bolt and is reinforced on the underside.
- Keep lines clear of propellers on both boats.
- Keep hands and feet clear of the other boat. Do not get caught or pinched between the two boats as severe injury could occur.
- Never hold a tow line after it is pulled taut.



# Specifications



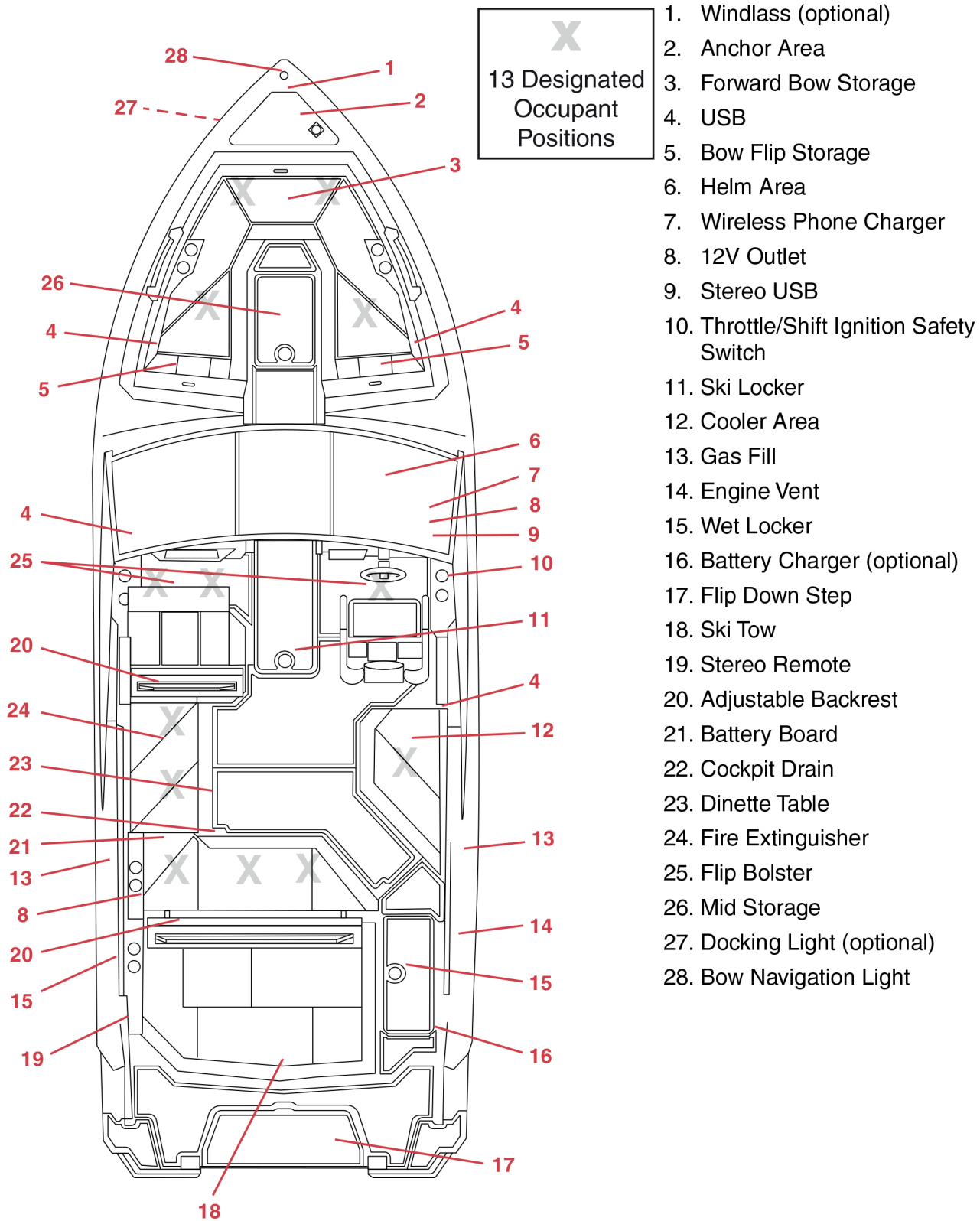

# R4

46 • SPECIFICATIONS





	Stern Drive .....	Surf
Length Overall w/o Engines	N/A.....	N/A
Length Overall w/Swim Platform	24'3" (7.39m) .....	24'3" (7.39m)
Beam	8'6" (2.59m) .....	8'6" (2.59m)
Deadrise	19° .....	19°
Fuel Capacity	50 gal (189.3 L).....	50 gal (189.3L)
Freshwater Capacity	N/A.....	N/A
Dry Weight	5,530 lb (2,508 kg).....	6,150 lb (2,790 kg)
Bridge Clearance	58" (1.47 m) .....	59" (1.50 m)
Bridge Clearance w/Tower	97" (2.46 m) .....	98" (2.50 m)
Draft, Drive Up	19.5" (0.50 m).....	31.5" (0.80 m)
Draft, Drive Down	26.5" (0.67 m).....	39" (0.99 m)
Capacity	13 persons.....	13 persons
Capacity & Gear	2,100 lbs. (952 kg).....	2,100 lbs (952 kg)
Ballast	N/A.....	1,494 lb (678 kg)
Max Horsepower	430.....	430



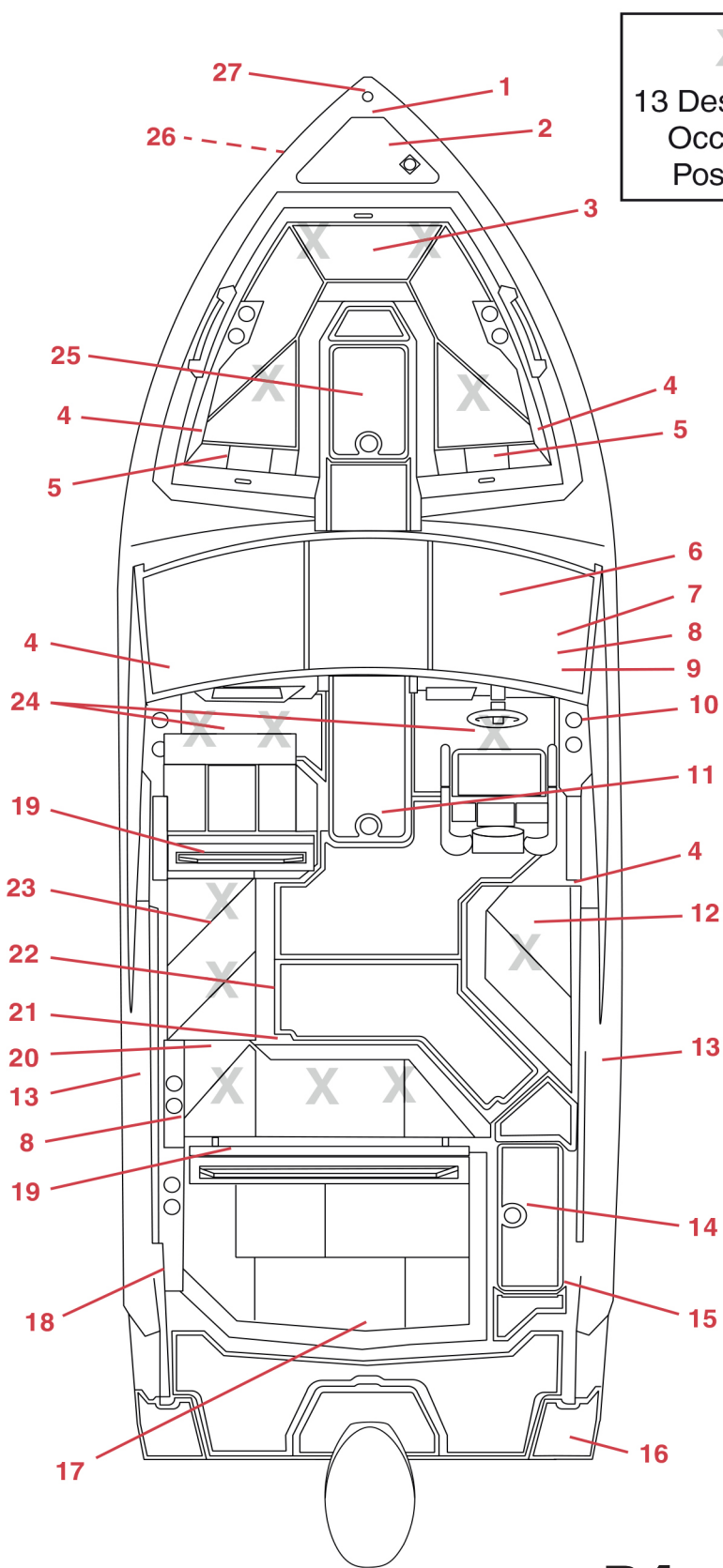

X  
13 Designated  
Occupant  
Positions

1. Windlass (optional)
2. Anchor Area
3. Forward Bow Storage
4. USB
5. Bow Flip Storage
6. Helm Area
7. Wireless Phone Charger
8. 12V Outlet
9. Stereo USB
10. Throttle/Shift Ignition Safety Switch
11. Ski Locker
12. Cooler Area
13. Gas Fill
14. Wet Locker
15. Battery Charger (optional)
16. Flip Down Step
17. Ski Tow
18. Stereo Remote
19. Adjustable Backrest
20. Battery Board
21. Cockpit Drain
22. Dinette Table
23. Fire Extinguisher
24. Flip Bolster
25. Mid Storage
26. Docking Light (optional)
27. Bow Navigation Light

# R4

## OUTBOARD

48 • SPECIFICATIONS



Length Overall w/o Engines	24'3" (7.39m)
Length Overall w/Swim Platform	N/A
Beam	8'6" (2.59m)
Deadrise	19°
Fuel Capacity	70 gal (265 L)
Freshwater Capacity	N/A
Dry Weight	4,986 lb (2,262 kg)
Bridge Clearance	59" (1.50 m)
Bridge Clearance w/Tower	100" (1.50 m)
Draft, Drive Up	19" (0.48 m)
Draft, Drive Down	34" (0.86 m)
Capacity	13 persons
Capacity & Gear	2,100 lbs. (952 kg)
Ballast	N/A
Max Horsepower	350



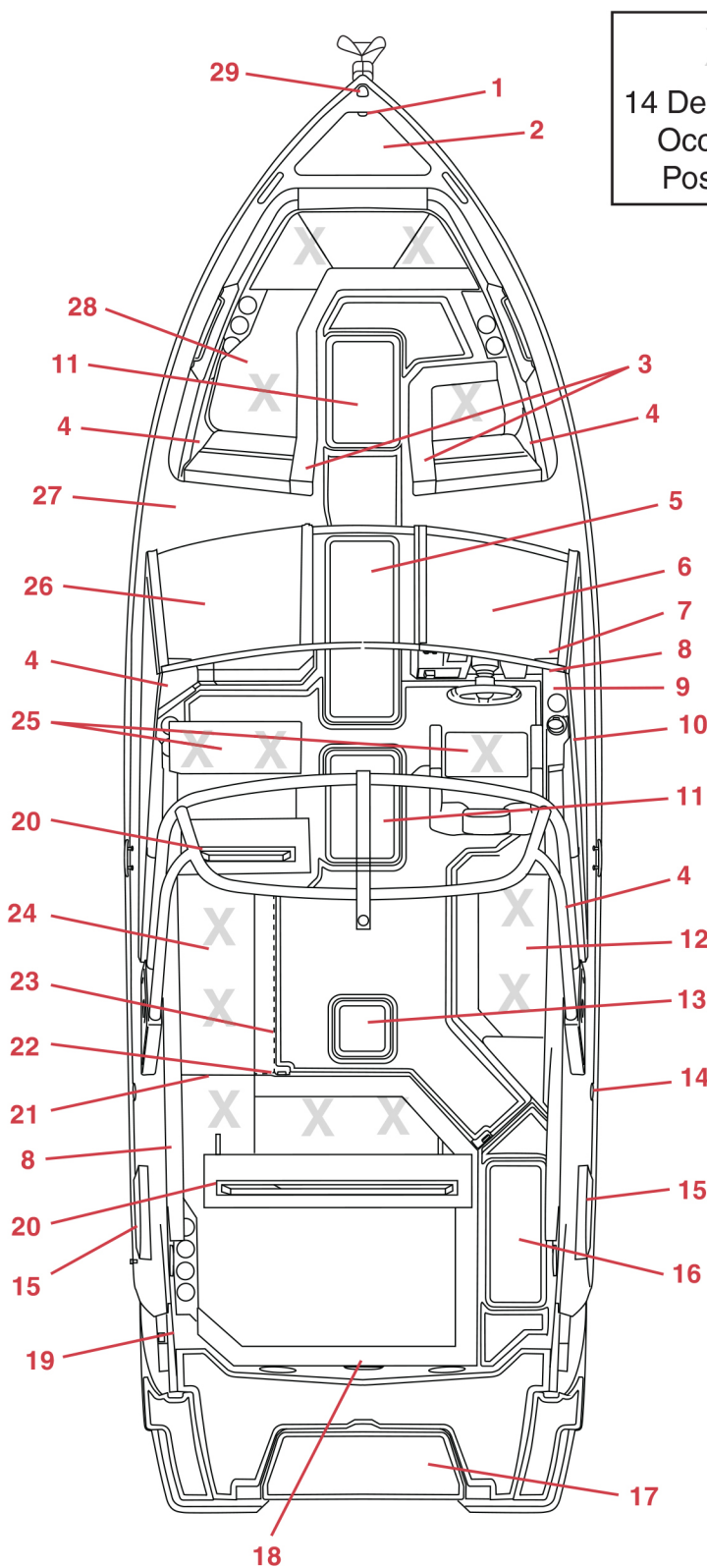

**X**  
14 Designated  
Occupant  
Positions

1. Windlass (optional)
2. Anchor Area
3. Armrest
4. USB
5. Ski Locker
6. Helm Area
7. Wireless Phone Charger
8. 12V Outlet
9. Stereo USB
10. Throttle/Shift Ignition Safety Switch
11. Mid Storage
12. Removable Ice Chest
13. Fuel Access
14. Gas Fill
15. Engine Vent
16. Wet Locker
17. Flip Down Step
18. Ski Tow
19. Stereo Remote
20. Adjustable Backrest
21. Battery Board
22. Cockpit Drain
23. Dinette Table
24. Fire Extinguisher
25. Flip Bolster
26. Head Area
27. Waste FTG
28. Port Storage
29. Bow Navigation Light

# R6

50 • SPECIFICATIONS





	<i>Sterndrive</i> .....	<i>Surf</i>
Length Overall w/o Engines	N/A.....	N/A
Length Overall w/Swim Platform	25'9" (7.85 m).....	25'9" (7.85 m)
Beam	8'6" (2.59m) .....	8'6" (2.59m)
Deadrise	17° .....	17°
Fuel Capacity	60 gal (227.1 L).....	60 gal (227.1L)
Freshwater Capacity	10 gal (37.9 L) .....	10 gal (37.9 L)
Dry Weight	5,800 lb (2,631 kg).....	6,100 lb (2,766 kg)
Bridge Clearance	61" (1.55 m) .....	61" (1.55 m)
Bridge Clearance w/Tower	100" (2.54 m) .....	102" (2.59 m)
Draft, Drive Up	19" (0.48 m) .....	30" (0.76 m)
Draft, Drive Down	35.5" (0.90 m).....	36" (0.91 m)
Capacity	14 persons.....	14 persons
Capacity & Gear	2,300 lbs. (1,043 kg) .....	2,300 lbs (1,043 kg)
Max Horsepower	430.....	430



**R6**



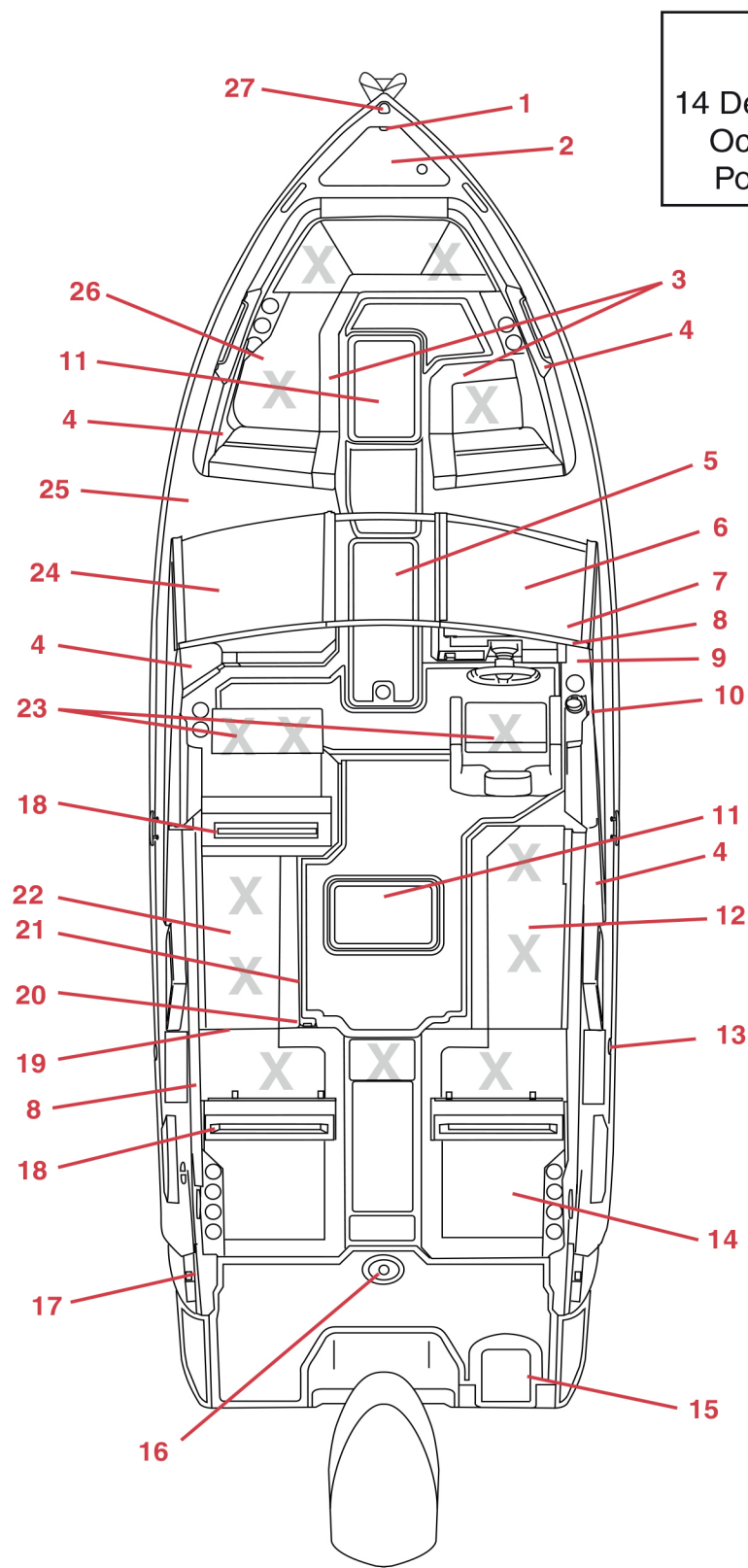

  
 14 Designated  
 Occupant  
 Positions

1. Windlass (optional)
2. Anchor Area
3. Armrest
4. USB
5. Ski Locker
6. Helm Area
7. Wireless Phone Charger
8. 12V Outlet
9. Stereo USB
10. Throttle/Shift Ignition Safety Switch
11. Mid Storage
12. Removable Ice Chest
13. Gas Fill
14. Wet Locker
15. Swim Step
16. Ski Tow (optional)
17. Stereo Remote
18. Adjustable Backrest
19. Battery Board
20. Cockpit Drain
21. Dinette Table
22. Fire Extinguisher
23. Flip Bolster
24. Head Area
25. Waste FTG
26. Port Storage
27. Bow Navigation Light

# R6

## OUTBOARD

52 • SPECIFICATIONS

Length Overall w/o Engines	25'5" (7.75m)
Length Overall w/Swim Platform	N/A
Beam	8'6" (2.59m)
Deadrise	18°
Fuel Capacity	80 gal (302 L)
Freshwater Capacity	10 gal (37.9 L)
Dry Weight	5,300 lb (2,404 kg)
Bridge Clearance	61.5" (1.56 m)
Bridge Clearance w/Tower	104" (2.64 m)
Draft, Drive Up	17.5" (0.44 m)
Draft, Drive Down	32.5" (0.83 m)
Capacity	14 persons
Capacity & Gear	2,100 lbs. (952 kg)
Ballast	N/A
Max Horsepower	350



**R6**  
OUTBOARD

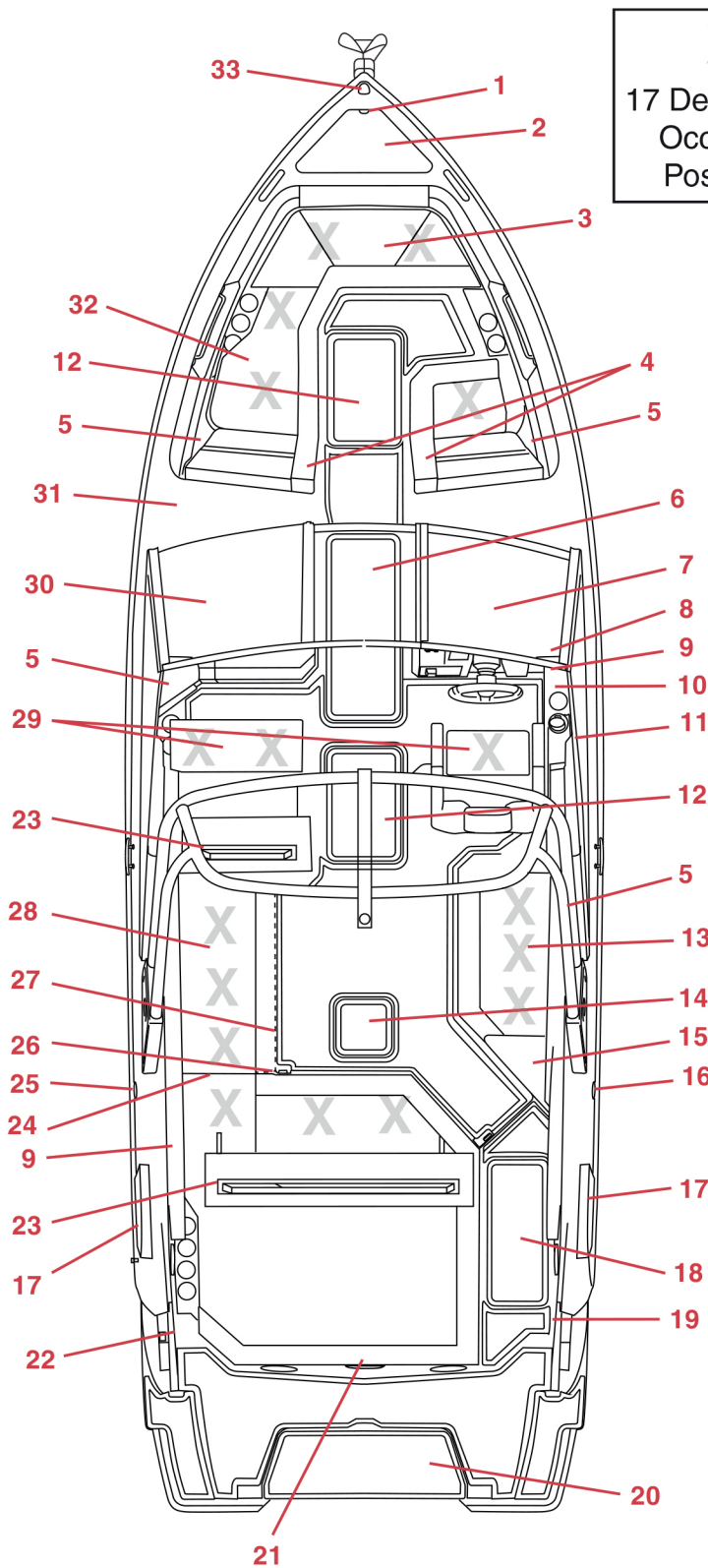

X  
17 Designated  
Occupant  
Positions

1. Windlass (optional)
2. Anchor Area
3. Forward Bow Storage
4. Armrest
5. USB
6. Ski Locker
7. Helm Area
8. Wireless Phone Charger
9. 12V Outlet
10. Stereo USB
11. Throttle/Shift Ignition Safety Switch
12. Mid Storage
13. Cooler Area
14. Fuel Access
15. Step
16. Gas Fill
17. Engine Vent
18. Wet Locker
19. Battery Charger
20. Flip Down Step
21. Ski Tow
22. Stereo Remote
23. Adjustable Backrest
24. Battery Board
25. Water Fill
26. Cockpit Drain
27. Dinette Table
28. Fire Extinguisher
29. Flip Bolster
30. Head Area
31. Waste FTG
32. Port Storage
33. Bow Navigation Light

# R8

54 • SPECIFICATIONS





	<i>Stern</i> drive .....	<i>Surf</i>
Length Overall w/o Engines	N/A.....	N/A
Length Overall w/Swim Platform	27'10" (8.48 m).....	27'10" (8.48 m)
Beam	8'6" (2.59m) .....	8'6" (2.59m)
Deadrise	19° .....	19°
Fuel Capacity	80 gal (302.8 L).....	80 gal (302.8 L)
Freshwater Capacity	10 gal (37.9 L).....	10 gal (37.9 L)
Dry Weight	6,400 lb (2,903 kg).....	6,700 lb (3,309 kg)
Bridge Clearance	62" (1.57 m) .....	61" (1.55 m)
Bridge Clearance w/Tower	102" (2.59 m) .....	103.5" (2.63 m)
Draft, Drive Up	18" (0.46 m) .....	29" (0.74 m)
Draft, Drive Down	35" (0.89 m) .....	36" (0.91 m)
Capacity	Yacht Certified .....	Yacht Certified
Capacity & Gear	Yacht Certified .....	Yacht Certified
Max Horsepower	430.....	430



**R8**



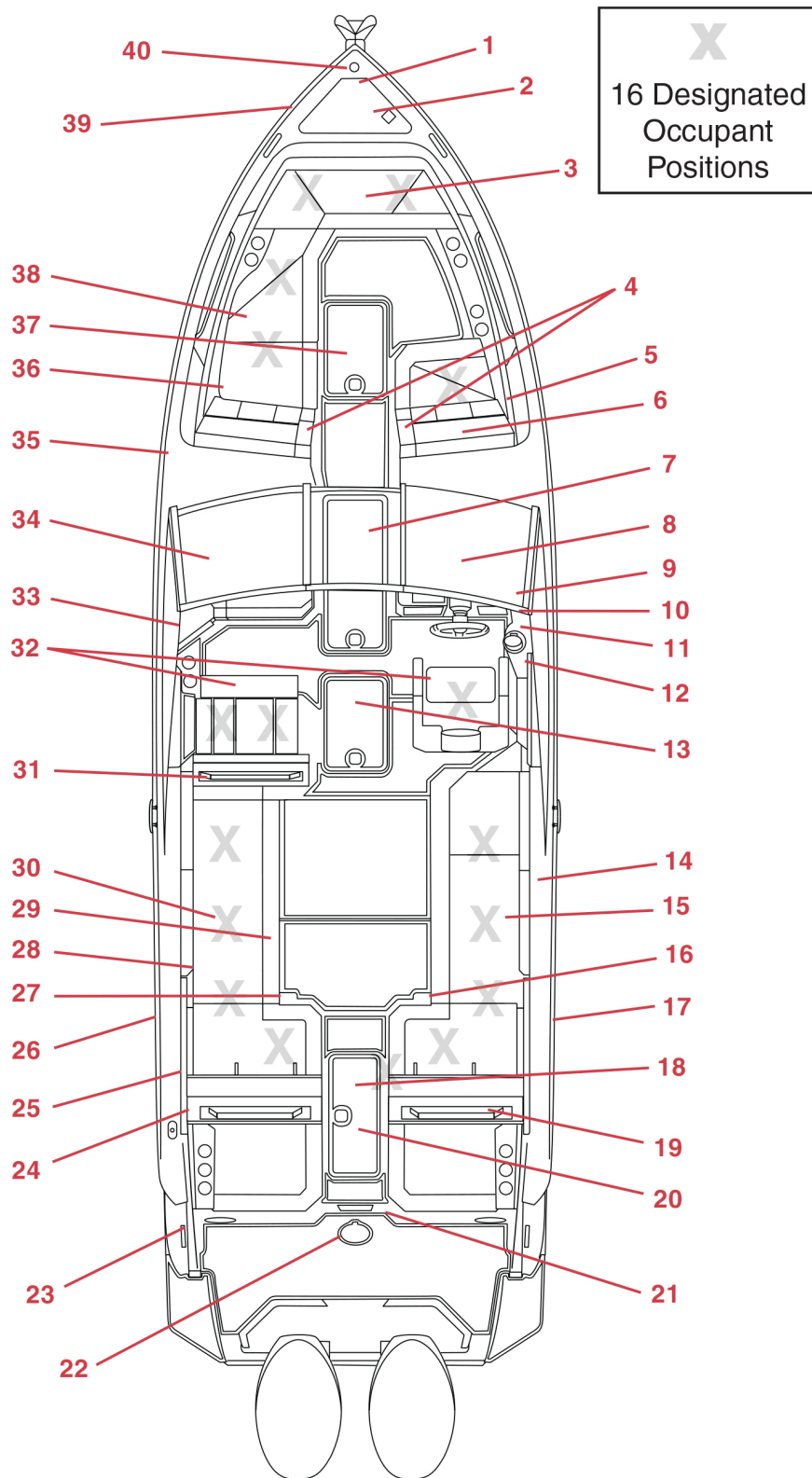

**X**  
16 Designated  
Occupant  
Positions

1. Windlass (optional)
2. Anchor Area
3. Forward Bow Storage
4. Armrest
5. USB
6. Bow Flip Storage
7. Ski Locker
8. Helm Area
9. Wireless Phone Charger
10. 12V Outlet
11. Stereo USB
12. Throttle/Shift Ignition Safety Switch
13. Mid Storage
14. USB
15. Cooler Area
16. Cockpit Drain
17. Gas Fill
18. Fuel Access
19. Adjustable Backrest
20. Wet Locker
21. 110V Outlet (optional)
22. Ski Tow
23. Stereo Remote
24. Adjustable Backrest
25. 12V Outlet
26. Water Fill
27. Cockpit Drain
28. Battery Board
29. Dinette Table
30. Fire Extinguisher
31. Adjustable Backrest
32. Flip Bolster
33. USB
34. Head Area
35. Waste FTG
36. USB
37. Mid Storage
38. Port Storage
39. Docking Light (optional)
40. Bow Navigation Light

# R8

## OUTBOARD

56 • SPECIFICATIONS





Length Overall w/o Engines	27'10" (8.48 m)
Length Overall w/Swim Platform	N/A
Beam	8'6" (2.59m)
Deadrise	19°
Fuel Capacity	125 gal (473.2 L)
Freshwater Capacity	10 gal (37.9 L)
Dry Weight	6,500 lb (2,948 kg)
Bridge Clearance	63" (1.60 m)
Bridge Clearance w/Tower	106" (2.69 m)
Draft, Drive Up	16" (0.41 m)
Draft, Drive Down	30" (0.76 m)
Capacity	Yacht Certified
Capacity & Gear	Yacht Certified
Max Horsepower (one engine)	425
Max Horsepower (two engines)	600





# Components and Systems



# INTRODUCTION

This section provides critical information about the mechanical, electronic, and manual operating systems on Cobalt boats. It describes basic operating characteristics and provides information for efficient use of the equipment and for prevention of casualties. Be sure to read and understand all information provided before operating any of these systems.

## WARNING

Regularly inspect and maintain all systems to prevent unexpected hazards associated with worn or faulty components. Be sure to replace system components and hardware with marine-grade parts, not automotive components. Additional care and maintenance information follows in this owner's manual.

# ROUTING

The following information is provided to assist new boat owners with the orientation of support systems within the boat. Consumers should **NEVER** attempt to make any repairs to these systems. If repairs are required, they should be undertaken **ONLY** by authorized Cobalt service technicians.

### R4 Fuel Routing

- 1—Fuel Fill (Deck)
- 2—Fuel Vent
- 3—Charcoal Canister
- 4—Engine
- 5—Fuel Tank

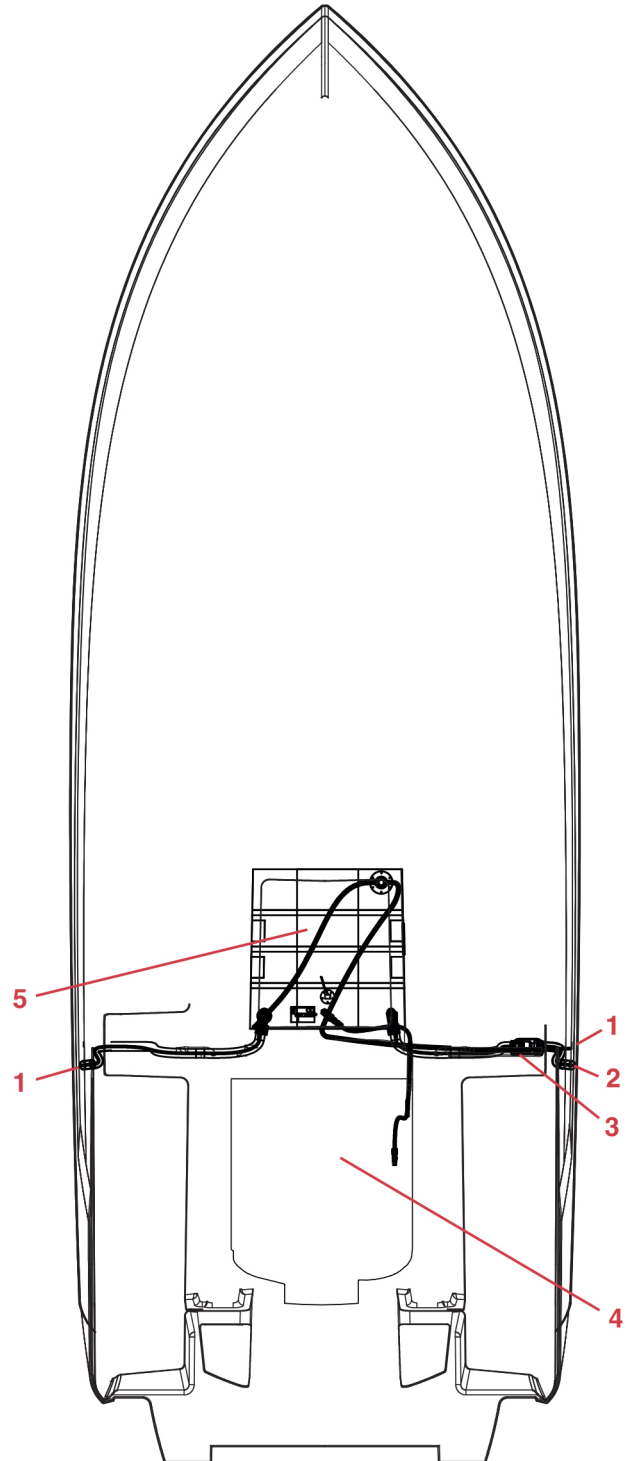

COB\_0561b\_A

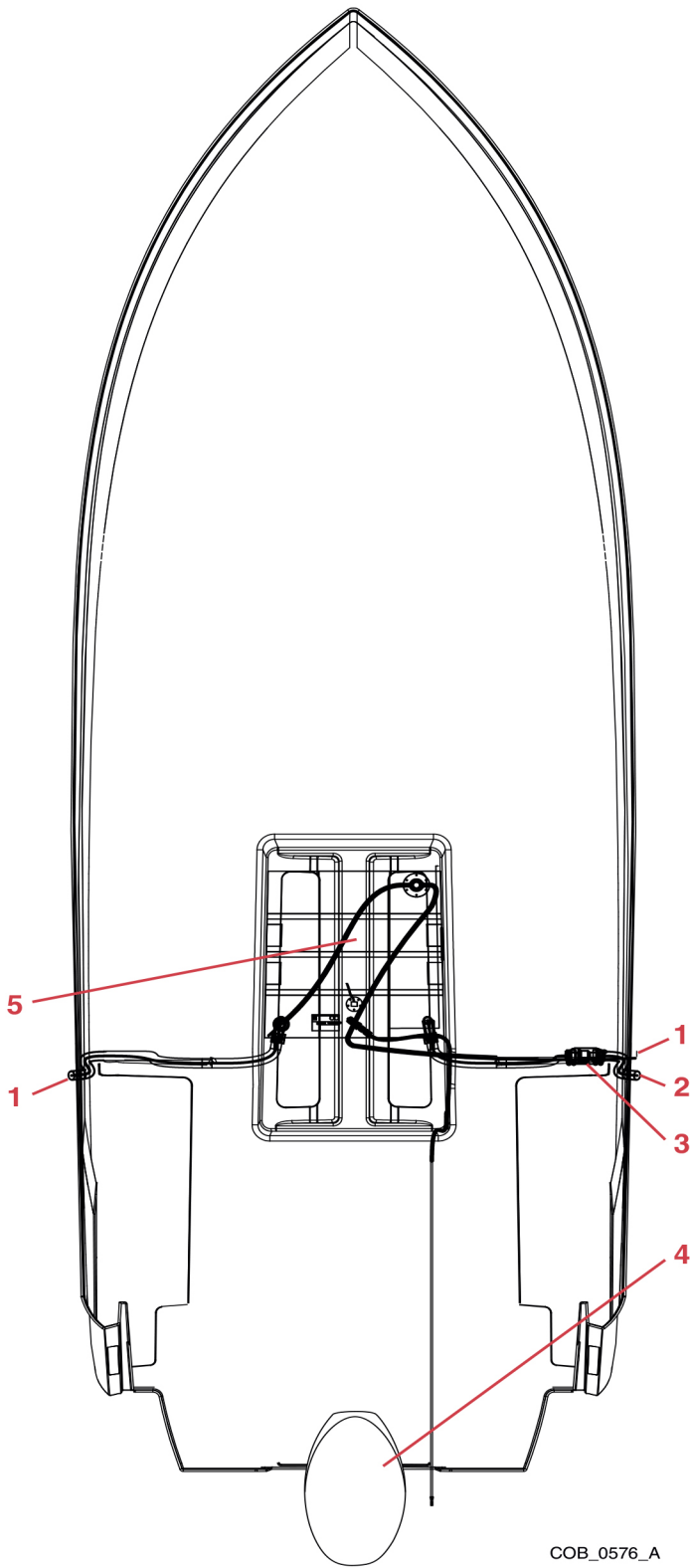

COB\_0576\_A

***R4 Outboard Fuel Routing***

- 1—Fuel Fill (Deck)**
- 2—Fuel Vent**
- 3—Charcoal Canister**
- 4—Engine**
- 5—Fuel Tank**

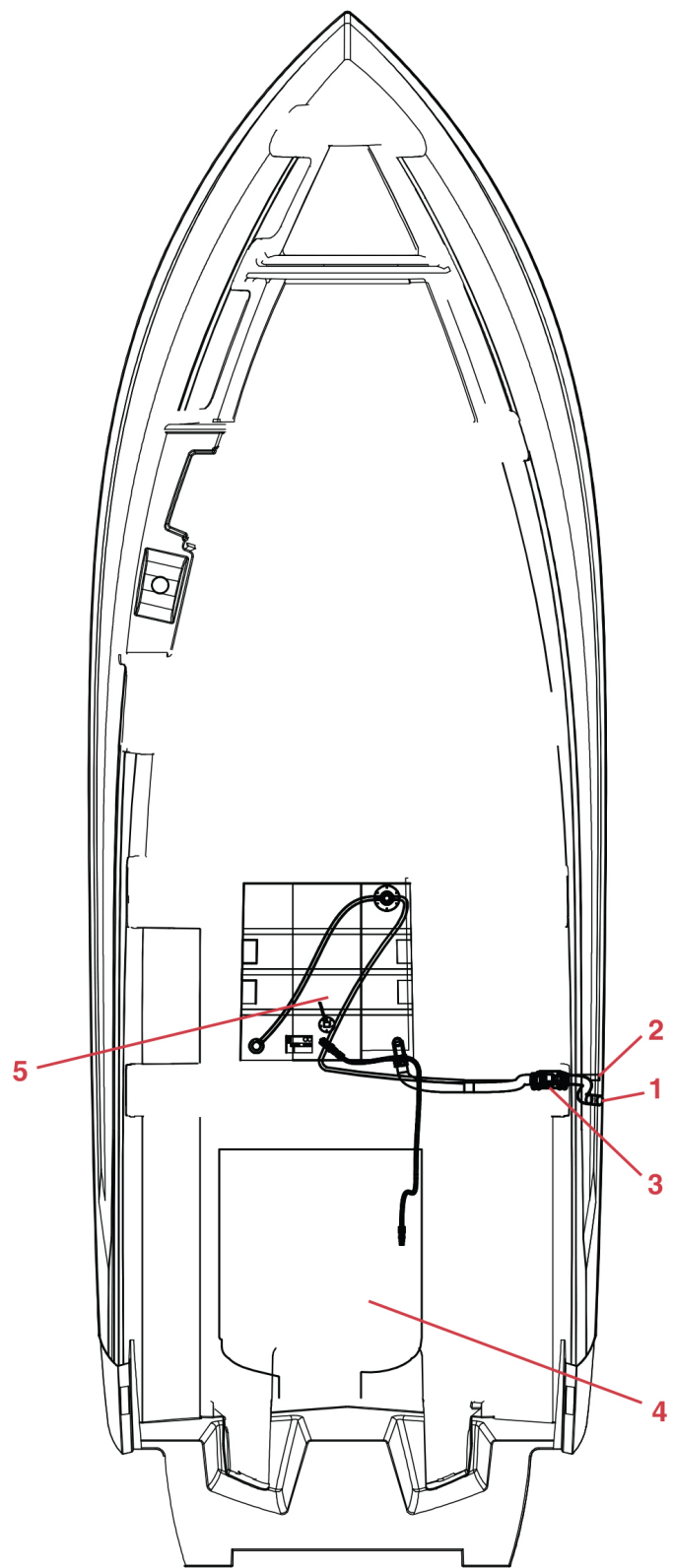

COB\_0561\_A

***R6, R8 Fuel Routing***

- 1—Fuel Fill (Deck)**
- 2—Fuel Vent**
- 3—Charcoal Canister**
- 4—Engine**
- 5—Fuel Tank**



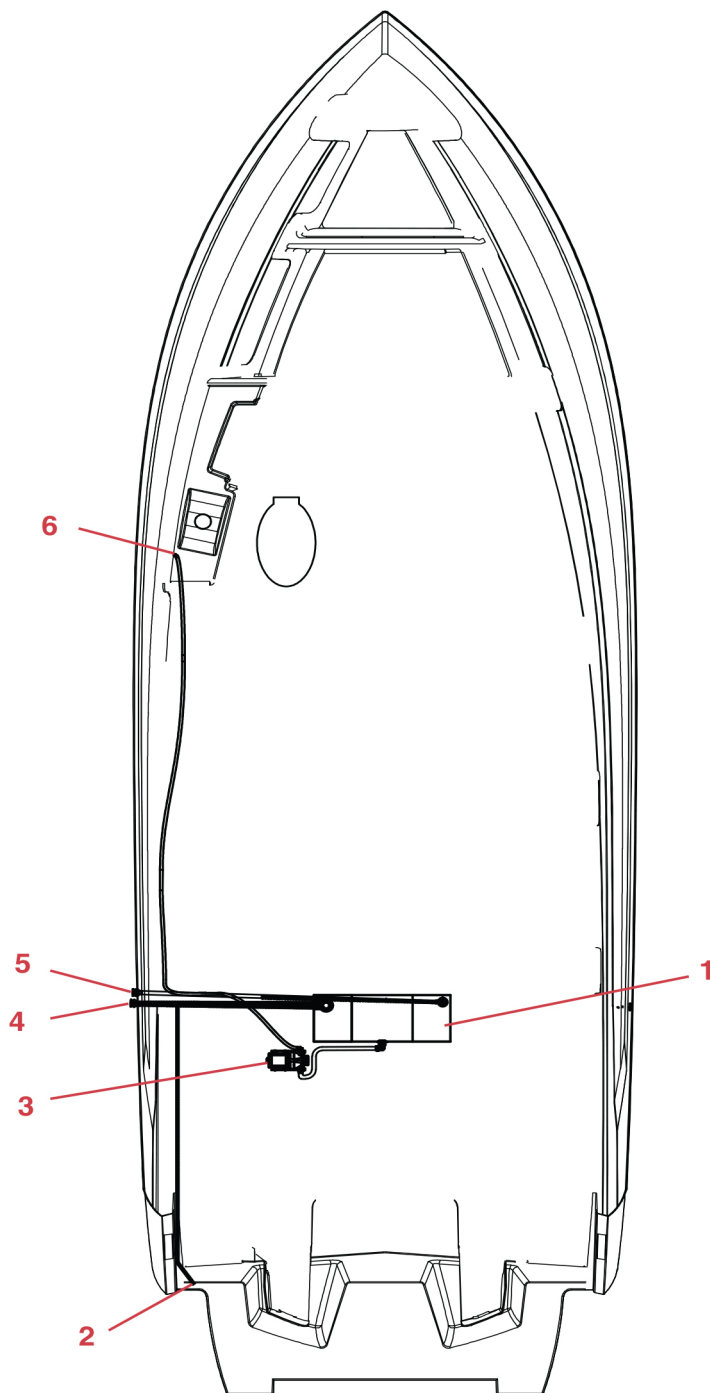

COB\_0562\_A

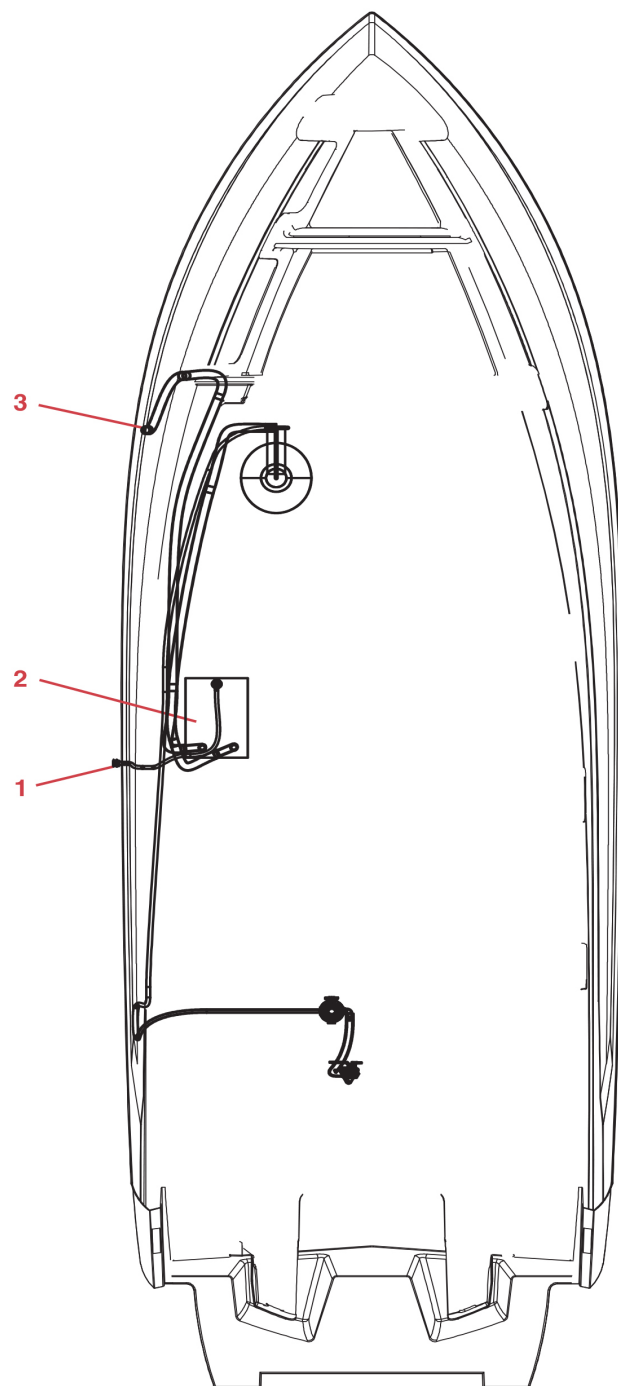

COB\_0562\_A

**R6 Fresh Water Routing**

- 1—Water Tank**
- 2—Transom Shower (Optional)**
- 3—Water Pump**
- 4—Fresh Water Fill (Tank)**
- 5—Fresh Water Vent (Hull)**
- 6—Water Supply Sink**

**R6 Waste Water Routing**

- 1—Water Vent**
- 2—Waste Tank**
- 3—Waste Fill**



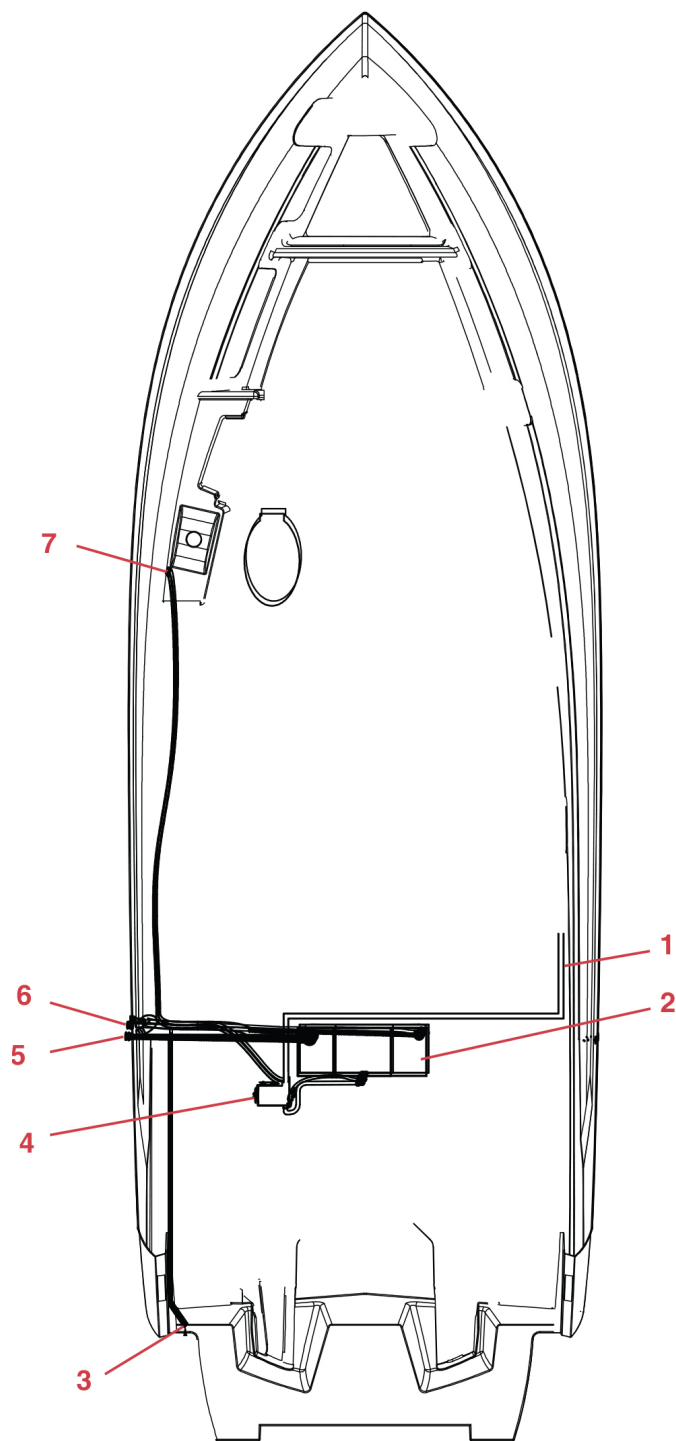

COB\_0562\_B

***R8 Fresh Water Routing***

- 1—Galley Sink (Optional)**
- 2—Water Tank**
- 3—Transom Shower (Optional)**
- 4—Water Pump**
- 5—Fresh Water Fill (Deck)**
- 6—Fresh Water Vent (Hull)**
- 7—Head Sink (Optional)**

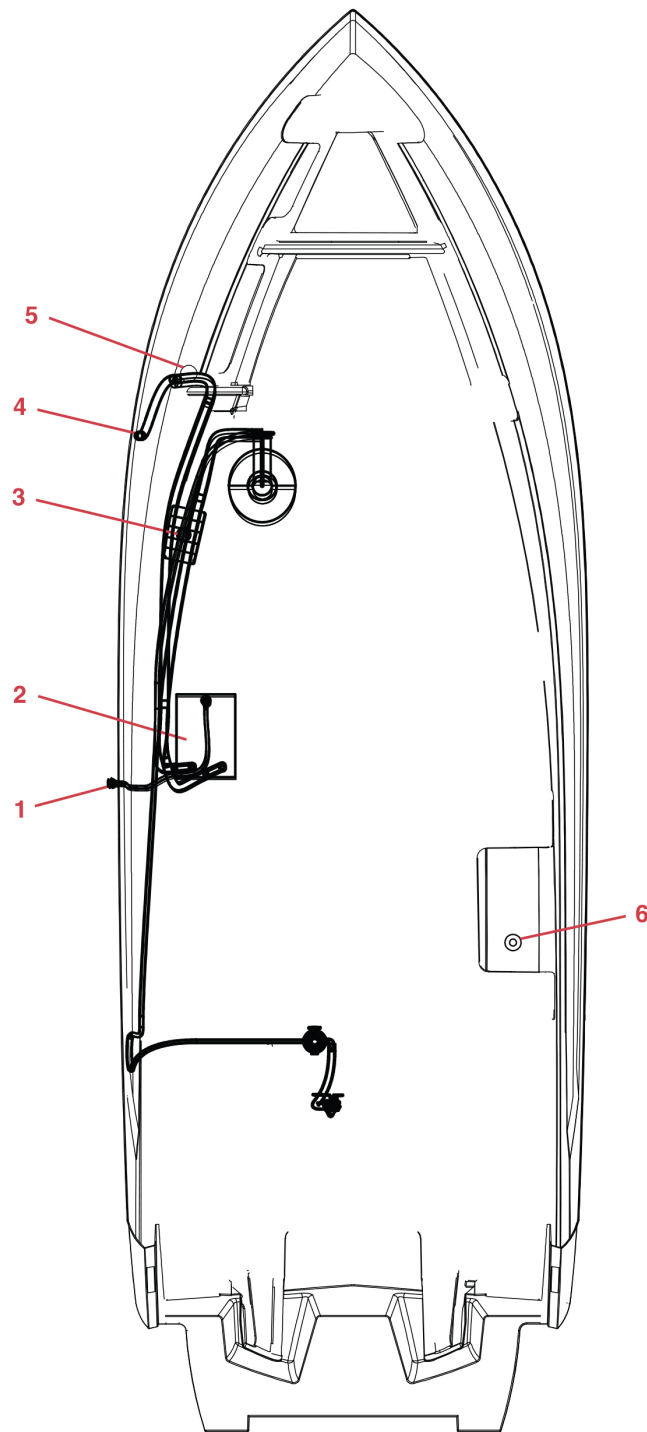

COB\_0563\_B

***R8 Waste Water Routing***

- 1—Water Vent**
- 2—Waste Tank**
- 3—Head Sink Drain**
- 4—Waste Pump Out**
- 5—Waste Fill**
- 6—Galley Sink Drain**



# FIRE SUPPRESSION EQUIPMENT

Even when surrounded by water, fire is a significant concern. In fact, because safe egress from the boat is limited if it becomes necessary to abandon ship, this issue reinforces the need for easily accessible PFDs.

**When boating in the United States, boats of less than 26 feet in length are required to have at least one B1-rated, hand-held fire extinguisher onboard and fully charged, unless there is an automatic fire extinguishing system installed.**

An automatic system is available as an option on Cobalt boats. Hand-held units are not included in standard equipment so that the consumer can choose from a wide range of fire extinguishers, many of which exceed the minimum requirements. **If the boat does not have an automatic fire extinguishing system installed, the boat owner MUST purchase and install at least one B1-rated fire extinguisher.**

**Most countries have fire extinguishing and suppression requirements for recreational boats. It is the responsibility of the boat owner and/or operator to determine the requirements for the body of water on which the boating will occur. To avoid citations and/or arrest, boaters should check with local governmental agencies regarding specific requirements and limitations for boating on the applicable body of water.**

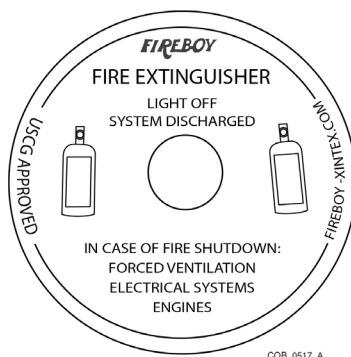

If your Cobalt boat is equipped with a fixed automatic fire extinguisher that uses **Clean Agent HFC-227ea** as an extinguishing agent, it is mounted in the engine compartment and generator compartment (if equipped). These extinguishers are activated when the heat-sensitive head reaches a predetermined temperature. The extinguisher discharges and saturates the engine and/or generator compartment, smothering the fire.

## WARNING

**Whenever fire extinguishers or suppression units have been used in fighting an onboard fire, a careful determination should be made whether it is safe to operate the boat. In most instances, it is advisable to have the boat towed to shore rather than risk additional fire or permanent damage to the drivetrain. The boat should be thoroughly serviced by an authorized Cobalt dealer prior to operation again. Operation prior to service could result in additional damage to the boat and may result in serious injury or death.**

## WARNING

**DO NOT open the engine compartment hatch immediately. This will allow oxygen to reach the fire, and flashback can occur. When the fire extinguisher discharge occurs, turn off all engine(s), bilge blowers and electrical system components.**

Following discharge of fire suppression material, the system will require recharging. If an automatic system has discharged, it is unlikely that the boat can be run. Cobalt recommends getting a tow to shore and having the engine compartment thoroughly cleaned and the fire suppression system recharged prior to running the boat's engine again. If hand-held units have been discharged, these will also require recharging. The chemicals in all fire suppression units can discolor upholstery and carpeting.

It is recommended that the boat be cleaned as soon as practical. The fire suppression manufacturers provide information regarding the proper and appropriate cleaning agents. Also, pay attention to the cleaning instructions provided in the *Interior/Exterior Care and Maintenance* section of this manual to avoid permanent damage to materials.

Even if systems are not discharged, fire extinguishers and suppression units require periodic maintenance. For a factory-installed automatic fire suppression system, a check of the system should be part of the routine annual maintenance. Hand-held units should be examined regularly for rust, corrosion, damage, or leakage. Weigh the unit annually to be certain that it meets the minimum listed on the label. If it has been used, even partially, it should be recharged by a qualified fire-extinguisher servicing company.

When purchasing fire extinguishing and suppression units, Cobalt strongly recommends buying units that are prepared specifically for the marine environment. The standards for these units have been established by the U.S. Coast Guard and the American Boat and Yacht Council (ABYC). In other countries, follow the recommendations and requirements of local jurisdictions and boating authorities.

**Cobalt recommends fire extinguishing and suppression units and system that exceed the minimum requirements.** While an automatic fire suppression system is highly effective in most instances of an engine compartment fire, it is possible that a fire could occur in another area of the boat. **Therefore, Cobalt recommends always having at least one hand-held unit fully charged and onboard, even if the boat is equipped with a suppression unit.**



## Fire Extinguisher Manual Pull

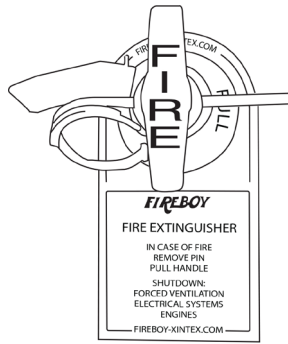

In case of fire in the engine compartment (where equipped), shut off all engines and blowers. Do not open the motor box. Where equipped, pull the handle(s) to the fixed fire extinguisher system located at the helm to discharge extinguishing agent into the engine compartment.



## Fire Port

In case of fire on the vessel that may involve electrical components or wiring, and boat operations are not required, turn off all battery switches. Use the fire extinguisher(s) or fire extinguishing agents as appropriate.

In case of fire in boats built with an engine compartment, shut off all engines and blowers. Do not open the

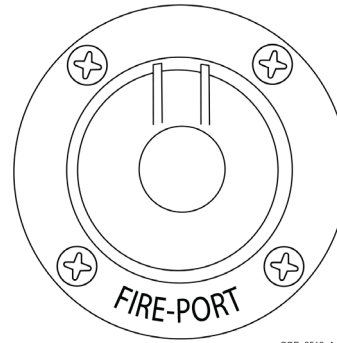

COB\_0518\_A

motor box. If applicable, pull the handle(s) to the fixed fire extinguisher system located at the helm to discharge extinguishing agent into the engine compartment(s).

Or, if applicable, locate the fire port opening on the motor box and fully discharge properly sized

flooding, clean agent fire extinguisher into the compartment.

**NOTE:** There may be more than one fixed system if a generator is installed.

Small portable fire extinguishers are for small fires as noted above and may not be the proper size or agent for flooding the engine and/or generator compartment.

Refer to an authorized Cobalt dealer for more information and assistance.

# ELECTRICAL SYSTEM

The Cobalt boat has a 12-volt DC system with a negative ground. The positive wire supplies the electrical charge and feeds current from the batteries to all 12-volt equipment; the negative wire is the ground.

The DC components are controlled from the helm switches. If your Cobalt boat has a cabin, it may have an electrical system panel that supplies 12 volts to these types of accessories:

- Cabin lights
- Cockpit lights
- Head
- Freshwater pressure pump
- Air compressor
- Entertainment system

An authorized Cobalt dealer can assist in determining the type and extent of the boat's electrical system.

Due to the complexity of the boat's wiring, much of which is inaccessible inside the hull and under the deck, any time an issue is suspected involving the wiring or any of the harnesses, the boat owner is strongly encouraged to have the boat serviced by an authorized Cobalt dealer.



**Electrical wiring or harness issues should always be addressed by an authorized Cobalt dealer. Alteration of wiring from the original Cobalt design could result in shock hazard, potential spark that could lead to fire, or other danger situations. Any disruption of the wiring from its original**

**plan and resultant damage to components or the boat is not covered under warranty. Individuals could also be injured by such error.**



## Circuit Breaker Panel

Many features on your Cobalt boat are controlled by electrical current. To protect persons onboard and boat features, the current may be interrupted by circuit breakers. These breakers prevent damaging electrical surges or overloads on the entire system.

Most electrical standard equipment devices are controlled with circuit breakers located in the starboard bow storage compartment.

When a circuit breaker senses an overload or some other issue (such as water intrusion) that places operation in jeopardy, the breaker will activate, or "pop." If the cause is relatively minor, power can quickly be restored to that particular circuit by pressing on the circuit button. Which circuit is affected should be obvious when looking at the breaker box in the starboard bow storage compartment as it will not align with the other circuit breakers' positions. Clear the fault before resetting the breaker. In the event the fault cannot be cleared, contact your Cobalt dealer immediately before resetting.

The breakers are labeled to identify the device protected. These breakers will activate if overloaded and

cut power to the switch. To restore power, turn off the device, push the breaker button in and release. If the button continues to pop out when the device is used, see your authorized Cobalt dealer.



## Fuses

Some accessories or electrical components have in-line fuses in them. Check the failed component for the possibility of an in-line fuse if a tripped circuit breaker is not found. (Some of these accessories or electrical components may not be included or available on your boat.)

Unlike circuit breakers which will reset, fuses must be replaced. They will be marked as to size. **Replace only with the size specified.** Any other could result in damage to the system or to other components. Boat owners are encouraged to keep a supply of replacement fuses in an enclosed, waterproof container onboard at all times.



## Battery Connections



**Avoid the potential of explosion from shorting or arcing. Keep the battery connections tight and clean, the terminal covers in place and the battery(ies) secure in the restraint system.**

Loose battery connections can cause errant signals to the boat's electrical system.

Read and understand the safety information on or supplied with your battery(ies). Maintain the battery(ies) following the manufacturer's recommendations.

**Use marine-rated batteries only! Never use automotive batteries as they do not have the additional protection necessary to function in a boat where water and humidity are always factors.**



**If it becomes necessary to recharge a battery from an external source, DO NOT attempt to charge using automotive battery cables or use another boat battery as the source for charging. Some amounts of hydrogen gas are emitted during the charging process. This can be very dangerous. It is critical to keep all sparks, including lit cigarettes, lighters, or any type of flame, well away from a charging battery. Use the optional battery charger sold by authorized dealers, or a similar aftermarket battery charger. Using the wrong type of charging procedure or improperly charging a battery can result in an explosion and/or fire that could lead to serious injury or death.**



**Inside the battery is an electrolyte fluid that allows the chemical reaction to provide power. The fluid is comprised of several components, one of which is sulfuric acid. As with most acids, this is caustic and corrosive. If the acid comes in contact with skin, immediately flush the area with copious amounts of fresh, clean water. Follow up with medical assistance.**

**Batteries used in tandem must always use the same chemistry!** Mixing battery types can cause damage to the electrical system, which is not covered under warranty.



**Failure to use marine-rated batteries in your boat could result in electrical system interruptions that could strand your boat during an outing. It is possible for water and the high humidity associated with operation on the water to affect batteries. If a battery, even marine-rated, becomes wet, allow it to dry before trying to start the engine. Water can cause a shortage at the battery terminals, which would prevent operation. Damage to other components due to the use of inappropriate batteries or failure to properly maintain batteries is not covered under warranty.**

## Connecting/Disconnecting Batteries

The posts on a battery are marked negative (-) and positive (+), one of each on top and separate by some space. The battery cables are color-coded, black for negative and red for positive.

Cobalt recommends having your authorized Cobalt dealer install the batteries. Consumers can perform this procedure, provided common sense safety guides the process.

If batteries have not been previously installed:

Step 1: Ensure the engine is OFF, and the battery switch is OFF on boats so equipped.

Step 2: Place the batteries in the containers.

Step 3: Attach the positive cable to the secondary (2) battery, attaching the positive (+) cable to the positive (+) post.

Step 4: Attach the positive cable to the primary (1) battery, attaching the positive (+) cable to the positive (+) post.

Step 5: Attach the negative (-) cable to the secondary (2) battery, attaching the negative (-) cable to the negative (-) post.

Step 6: Attach the negative (-) cable to the primary (1) battery, attaching the negative (-) cable to the negative (-) post.

Step 7: A separate cable is attached between the two negative (-) posts on the (1) and (2) batteries for additional ground.

Step 8: Check that all cables are secure. Do not torque any connections; hand-tighten securely using a wrench. Never round off any of the nuts used to secure the cables. If a nut will not tighten, do not force it. Seek assistance to determine if the nut is the wrong size or some other issue exists.

If a battery requires replacement, reverse the steps above. **Never replace a battery with the boat electrical system ON.** Even if only one battery requires replacement, follow the steps and disconnect/then reconnect cables as directed above.

**⚠ DANGER**

Never touch positive (+) and negative (-) posts or connections simultaneously during installation! Never attempt to install or replace batteries with the boat electrical system ON, or in the presence of gas fumes. An electrical spark caused by connection to a functional battery can cause an explosion or fire, which is likely to cause serious injury or even death. This can also cause substantial damage to the electrical system, which is not covered under warranty.



## FUEL SYSTEM

**⚠ DANGER**

The fuel system, including the fuel lines, filter, and pump, should never be serviced by any person other than an authorized Cobalt-trained service technician.

**⚠ DANGER**

The flammability of gasoline and its explosive properties must always be respected. At the first odor of gasoline, the propulsion unit (engine) should be shut off and remain off until the source of the odor has been identified and the issue has been rectified.

### Fuel Requirements

Cobalt fuel systems are designed to meet all current ABYC and NMMA regulations using gasoline (petrol) with up to 10% ethanol.

**⚠ WARNING**

**DO NOT** use fuels containing methanol (methyl alcohol) or other fuels with more than 10% ethanol (ethyl alcohol) content such as E85, which contains 85% ethanol.

**NOTICE**

Use of incorrect fuel can result in damage to the propulsion unit (engine) that is not covered by the propulsion unit manufacturer nor by Cobalt. Failure to follow maintenance requirements may also void the warranties.

Fuel that contains more than 10% ethanol voids all

warranties and will increase the risk of damage to the engine(s), fuel system components and will also lead to the following;

- Corrosion of metal parts;
- Deterioration of plastic, rubber parts or permeation of fuel through rubber fuel lines;
- Leaking fuel resulting in explosion and/or fire;
- Starting and operating difficulties;
- Potential damage to your engine.



### Fueling

**⚠ DANGER**

Take care not to spill gasoline. If gasoline is accidentally spilled, wipe up all traces of it with dry rags and immediately dispose of the rags properly ashore.

**NOTICE**

Spilled fuel may yellow the gelcoat finish and damage gunwale trim. Such damage is not covered under warranty.

**⚠ DANGER**

Take all precautions every time you fuel your boat, regardless of the fuel type. Certain fuel is extremely flammable and highly explosive under certain conditions. Fumes from improperly stored rags can collect in bilge and be extremely hazardous.

**! DANGER**

Operate the blowers for at least four (4) minutes.

**NOTICE**

Prevent unwarranted engine damage. Use the recommended fuel type and octane rating. Refer to your propulsion unit operator's manual.

**! DANGER**

Fuels are extremely flammable and highly explosive under certain conditions.

- Stop engines, generators and any fuel-operated machinery.
- **DO NOT** smoke or allow open flames or sparks within 60 ft (15 m) of the fuel area.

**! DANGER**

Never smoke nor operate any spark-producing object within a 60-foot range (15 meters) of the boat when fueling. Fumes from gasoline are more likely to produce an explosion and/or fire than the actual fuel.

- Avoid damaging fuel lines and connectors, and the contact of fuel on hot engine parts.
- **DO NOT** store fuel in any containers or compartments which are not designated for fuel storage.
- Clean up any spilled fuel immediately and dispose of rags properly ashore.
- Know the dangers associated with fuels.

**! DANGER**

Each time you refuel, inspect all fuel lines, hoses and connections for leaks and deterioration.

- The Federal Water Pollution Control Act prohibits the discharge of oil or oily waste into the water. Violators can be fined \$5,000.00. Operation is also affected by the MARPOL Treaty. (See the **Safety** section of this owner's manual for more details.) We urge you to protect our fragile environment by avoiding any type of discharge, including trash or litter, into our waterways.

**When Fueling:**

1. Know your fuel tank capacity. Be sure to have enough fuel to reach your destination. If departing for an extended cruise, know the availability of fuel along your route. Practice the One Third Rule: one-third to reach the destination, one-third to return and one-third in reserve.
  - a. Even when the fuel system is carefully attended, some water may get into the fuel tank or separate from the fuel that is pumped into the tank. If

there is water present, it will settle on the bottom of the tank. If the pump begins to reach any water, it may cause a malfunction in the engine. Therefore, it is advisable to avoid allowing the fuel level to get too low.

2. Avoid fueling at night, except under well-lit conditions.
3. Moor your boat securely to the dock. Know the location of the fire extinguisher in case of emergency.
4. Keep accurate records of your fuel consumption. A fuel log that tracks fuel use over time will help determine average consumption.
5. Close all doors, hatches, windows and other compartments.
6. Extinguish cigarettes, pipes and all other flame-producing items.
7. Make sure all power is off, and do not operate any electrical switches.
8. Remove the fuel filler cap.
9. Insert the hose nozzle and make sure the nozzle is in contact with or grounded against the fill opening. This will reduce the risk of static spark.

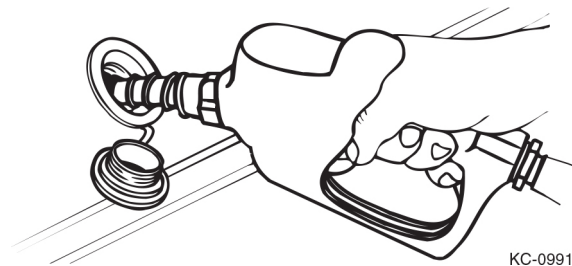

When your boat is equipped with the pop-up fuel filler cap, open by pressing the cap and turning the cap counterclockwise (approximately 10"); remove the cap.

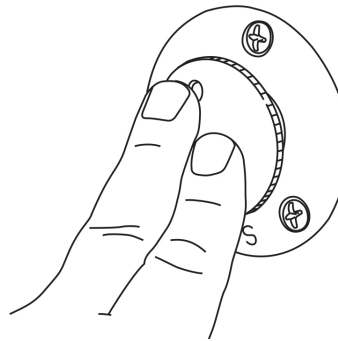

**To close:**

Reinstall the cap, press and turn clockwise. The fuel cap key is not necessary unless the cap is overtightened.

1. Add fuel in accordance with the propulsion unit operator's manual. Do not overfill, and allow enough

room for fuel expansion.

The fuel cap is retained by a chain to prevent losing the cap after it is opened. Be careful when fueling to avoid damaging the chain. If it breaks, have it replaced.

**After Fueling:**

1. Tighten the fuel fill cap using the fuel cap key unless your filler cap is the pop-up type. Wipe up any fuel spills.
2. Open all windows, hatches, doors and compartments.
3. Check all fuel lines, hoses and connections for leaks and deterioration.

- Be sure to run the blower for at least four (4) minutes before starting the engine. If you smell gasoline fumes, do not start the engine; continue to run the blower until the fumes have dissipated.



## EPA Fuel Tank

Your Cobalt boat may be equipped with a fuel system that has been designed and manufactured to meet the latest U.S. Coast Guard and EPA EVAP (evaporation) regulations. A decal located at the helm will indicate if your boat is equipped with this fuel system.

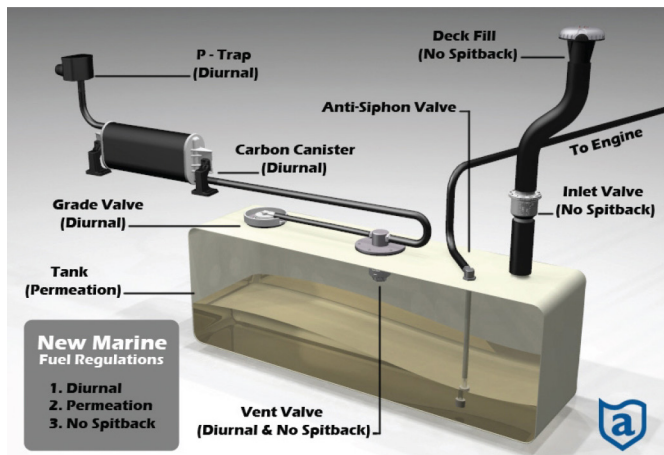

*Some of the new features in the fuel system:*

- There is no “spitback” at the deck plate when fueling. The filler nozzle automatically shuts off when the tank is full. Do not attempt to continue filling after the nozzle automatically shuts off, indicating the tank is full.
- A carbon canister is present to capture hydrocarbon molecules before air is vented outside the fuel system.

*When filling the tank for the first time:*

- Fuel vapor will expand within the tank, causing back pressure that may close the inlet check valve and cause the filler nozzle to prematurely shut off. To eliminate this problem, slowly add only about 2 gal (7.5L) of fuel and stop. Wait a few minutes to let the pressure within the

system stabilize; then proceed filling the tank.

- During the first few fills, the new carbon canister within the vent line may generate heat from being initially saturated with hydrocarbons and cause water droplets to emit from the outside air vent. This is normal. After the first two or three fills, this should not happen.



## Troubleshooting

### New tank is hard to fill/nozzle keeps shutting off.

This is called the “Green Tank Effect.” With a new tank that has never been fueled, the internal tank volume is completely filled with fuel vapor, very similar to what also occurs in non-diurnal tanks. The difference is that the newer tanks do not cause significant spitback. Instead, the nozzle shuts off. When filling a tank for the first time, the fuel vapor expands and builds back pressure, shutting the inlet check valve and causing the nozzle to shut off.

To eliminate this problem, add a few gallons to the tank very slowly and allow it to sit for several minutes. Then proceed with normal filling.

### Hot air comes out of the vent and drips liquid.

This is completely normal. When a tank is filled for the first time, the canister becomes saturated with hydrocarbons and generates heat as it performs the intended function. This water from the vent is simply water vapor condensation as a result of the carbon canister operating correctly and stopping hydrocarbons (fuel vapor) from venting into the atmosphere. After the first two or three fills, the system will stabilize, and this will cease.

### Cannot “top off” or keep filling the tank after it shuts off.

This is due to EPA regulations preventing overfilling the tank with the purpose of preventing expansion which could cause fuel to overflow through the vent.

**DO NOT CONTINUE TO FILL THE TANK AFTER IT IS FULL AND THE NOZZLE SHUTS OFF.**

## FRESHWATER SYSTEM

If your Cobalt boat is equipped with a transom shower, and/or a standard or optional galley, the system allows for fresh water to be pumped onboard. A 12-volt DC water pump operates the system. It is necessary for the boat’s battery(ies) to be turned on for the water system to operate. Refer to additional details elsewhere.

See *Specifications* in this owner’s manual, for your

boat’s freshwater capacity. In addition to information provided in the *Interior/Exterior Care and Maintenance* section of this owner’s manual, you can also consult with your authorized Cobalt dealer for winterization requirements.

# HELM AND INSTRUMENTATION

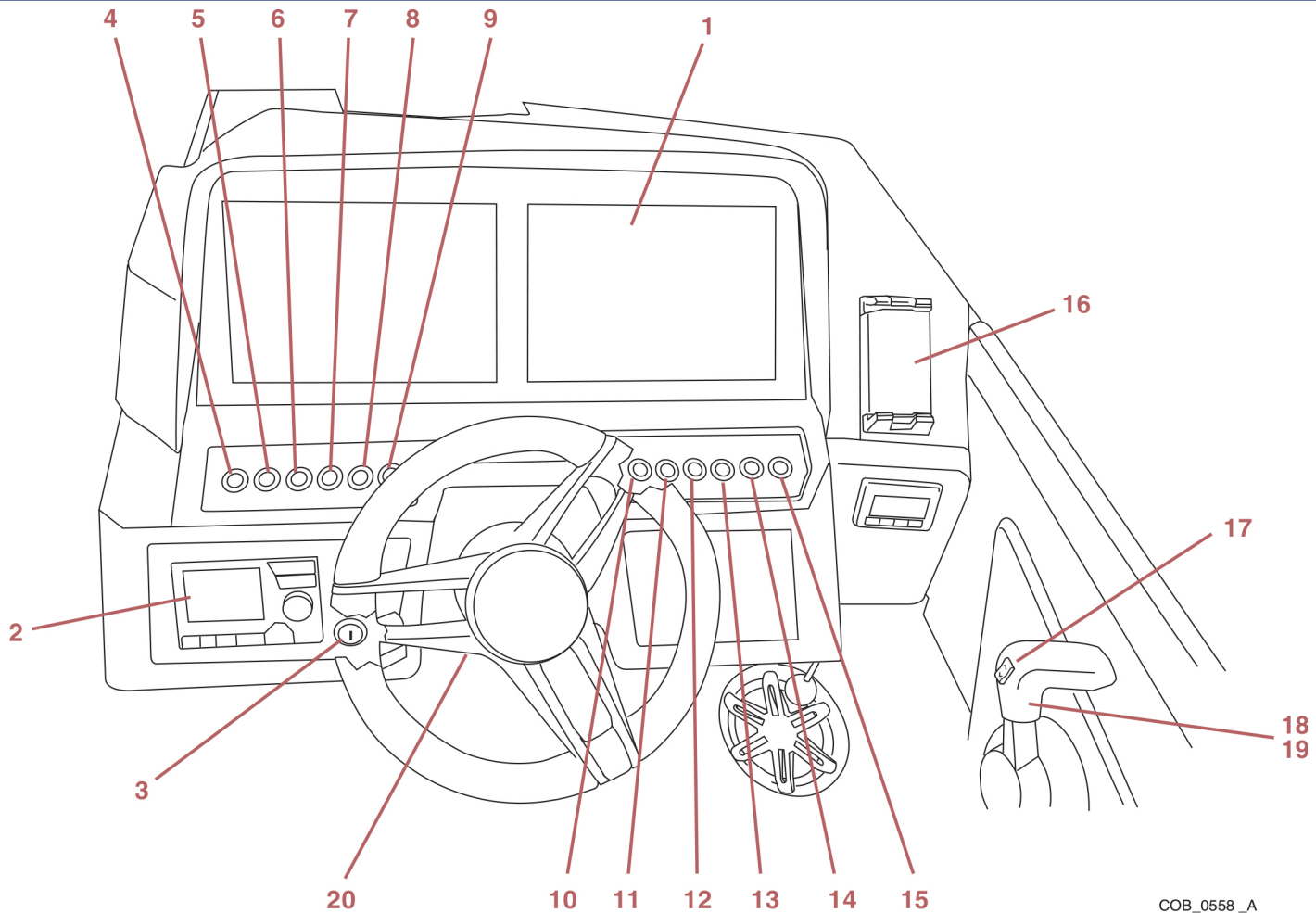

COB\_0558\_A

Your Cobalt boat helm will monitor and provide information about the boat's functions. The gauges are illuminated for night or low-light operation.

On occasion, a small fluctuation in a gauge reading is not unusual. If an instrument reading is outside the normal or recommended ranges, determine the cause or see your authorized Cobalt dealer.

Refer to the engine operator's manual for normal recommended ranges.

## **WARNING**

**If the safety of you or others depends on running the engine during abnormal conditions, make the right decision on saving equipment or lives. Do not jeopardize the safety of you or others to protect your boat.**

### 1. Glass Cockpit Dash Unit

**Smart Mode** screens are pre-programmed by Cobalt.

To access screens:

1. Press **HOME**, if not already there.
2. Press **Smart Mode**.
3. Select desired mode from **Smart Mode** screen.

## NOTICE

**To reset to default settings, contact your Cobalt dealer. Attempting to reset without guidance can cause malfunctions that may inhibit the ability to run the boat.**

A/V, Gauges/Control settings are auto-populated, depending on options; however, they can be customized. (For example, to adjust screen brightness, press and release the power button quickly.)

EVC is Volvo Penta's electronic engine control platform and is offered as an option. EVC connects the engine, transmission, instruments and accessories into one operating system. The result is high reliability, simple updates and access to smart accessories.

If your boat is equipped with EVC, when the engine is turned off, turn the key back to the ON position within two (2) seconds. The screens will stay on. From **Power Off**, it takes approximately 60 seconds for displays to boot up.

If your boat is equipped with EVC, the functions of the engine data will not populate without the Volvo trip computer option.

For more detailed information, you can review your owner manual on the screen under info or the *Garmin Quick Start Manual* in your boat owner's packet. You can also go to [garmin.com](http://garmin.com) under *Marine Device Software Updates* for the latest software updates, if desired.

2. **Stereo Head Unit** (*standard on dash, optional transom mount*)—This panel provides remote control of the stereo system from the helm. See additional information in the *Entertainment System* section following.

3. **Ignition Switch**—This switch starts the engine. It also supplies accessory power when turned to the left. Note that whenever the ignition switch is turned on, it is pulling power from the battery. Extended periods of leaving the switch turned to *Accessory* can drain a battery and eventually the boat engine cannot be turned on and run. Such action can result in being stranded away from the dock or shore.

 **WARNING**

- **Check the engine compartment for gasoline or vapors.**
- **Operate the blower for four (4) minutes.**
- **Verify the blower operation.**
- **Run the blower below cruising speed.**

4. **Horn**—This switch activates the horn. Press the switch to activate. Release to stop the sound. The horn is a safety feature to sound an alarm in the event of an emergency and to draw attention when maneuvering in areas where the line of sight is questionable or instances when attention seems warranted.

5. **Bilge Blower**—This switch activates the engine compartment ventilation blower to remove explosive fumes from the area. The blower must be operated for a minimum of four (4) minutes each time before starting the engine. In addition, the blower should be operated continuously when at idle or running at slow speeds. The LED will illuminate if the switch is ON. Additional information about this critical component is presented throughout this manual.

 **DANGER**

**Never overlook the requirement of operating the blower for a minimum of four (4) minutes when the engine is started, or running the blower continuously when at idle or slow speed as the build-up of vapors can result in an explosion resulting in serious injury or death.**

6. **Aft Bilge Pump**—This switch manually controls the aft bilge pump.

7. **Fwd Bilge Pump**—This switch manually controls the forward bilge pump.

 **WARNING**

**The bilge system is critical to ensuring safety. Excess water drains into the bilge and must routinely be pumped out to keep the boat afloat and in trim. Failure to pay attention to water removal can result in sinking the boat, resulting in possible serious injury or death.**

8. **Logo Light**—This switch provides illumination of the logo.

9. **Docking Lights** (*Optional*)—This switch operates the docking lights, where equipped. Docking lights are to be used for docking only. **It is illegal to use your docking lights while cruising.**

10. **Underwater Lights** (*Optional*)—This switch provides illumination underwater. **These lights should also be off during cruising; some locales legally require these be off when moving.**

11. **Accent Light (RGB) Switch and Dimmer** (*Optional*)—It is the operator's responsibility to know and comply with local laws. Although not universally regulated, some color lights may not be compliant with certain local ordinances. Please know your local marine lighting regulations before use.

12. **Cockpit Lights**—This switch provides illumination within the cockpit area. These lights are useful for movement by persons onboard. Cobalt recommends leaving them off unless the boat is moored, and people are expecting to move about the vessel.

13. **Anchor/Mooring Light**—All boats at anchor or moored must display a proper white anchor light. The anchor light (all-around light) is the white light that is installed into a receiver located aft of the cockpit. The anchor light must be visible from 360° and will remain on when operating the navigational lights.

14. **Navigation Lights**—**For Inland Rules only. Do not use in international waters.** You must use your navigation lights and anchor/mooring light when operating your Cobalt boat between sunset and sunrise, and when daytime visibility is limited (i.e., rain and fog). Before operating your boat, check with your local authorities for other requirements concerning the use of navigation lights. The U.S. Coast Guard and many maritime authorities require recreational vessels to display navigation and/or anchor lights when the boat is deployed and/or moving on the body of water during

periods of reduced visibility. The navigation lights are identified by a red light on the port side and a green light on the starboard side.

**WARNING**

Boat outings should conclude prior to dark. Visual sighting is critical to safe boating. In an emergency where the boat must be operated in darkness, use the boat's navigation and anchor lighting in accordance with local law and ordinances, which may restrict the type of lighting to be used; plus, sound signals to alert anyone in the area, and proceed slowly. After dark, it may be impossible to see other boats, submerged hazards, or the shoreline, which can result in damage to the boat that is not covered under warranty, and serious injury or even death.

15.**ACC**—This switch is available to operate other accessory items that require a switch to operate.

**CAUTION**

**DO NOT** connect an accessory that is drawing more than 10 amps to the accessory switch. A hazardous situation, failure or damage to the electrical system can occur.

16.**Cell Phone Charger**—The cell phone charger securely holds and wirelessly charges cell phones equipped with wireless-charging capability.

17.**Drive Unit Trim Switch**—This switch controls the trim angle of the drive unit and will maximize the performance and ride of the boat. Performance and ride enhancement result when combined with the optional trim tabs.

18.**Shift/Throttle Lever**—To the right of the boat operator is the shift/throttle lever. Any time the boat engine is off, the lever should be in the center upright position, which is **NEUTRAL** (meaning the boat is not in gear) and is apparent when it can be felt slotting in with an auditory click. Boats are not equipped with "Park" like land-based vehicles.

At the base of the throttle is a detent button. Pushing on the button disengages the transmission, thereby allowing use of the throttle without engaging the transmission. This is used for warm-up of the engine while it is still in **NEUTRAL**. Be sure to position the throttle vertically (neutral) before re-engaging the transmission by again pushing the button.

When shifting gears, always do so smoothly and briskly. Being either too hard and slamming the gears, or too tentative is hard on the shift/throttle system and can result in damage that is not covered under warranty.

Refer to the engine operator's manual for more information and functions of the remote control.

**DO NOT** shift when the engine is not running.

**WARNING**

Before starting the engine or engaging the transmission, be certain that there are no people in the water around the boat.

**DANGER**

Make sure all shift/throttle hardware and cables are regularly inspected and maintained by authorized Cobalt dealers. Improperly maintained controls are hazardous and may cause sudden loss of control.

**WARNING**

**DO NOT** shift from forward to reverse while the engine is at high RPM. Damage to the transmission will result. When shifting from forward to reverse, the system requires a brief pause in the **NEUTRAL** position to allow the engine to return to its idle position prior to moving into the opposite gear. Without the brief pause, action can cause the engine to shut off. The subsequent loss of control can cause damage to the boat and/or injury to persons in or around the boat.

When shifting from **NEUTRAL** to **FORWARD** or **REVERSE**, shift briskly and decisively.

Your Cobalt boat is equipped with a safety switch for "start in neutral-only" operation. The shift lever must be in the **NEUTRAL** position before attempting to start the engine. See the information above for more detail.

**19. Ignition Safety Switch**

**WARNING**

**DO NOT** allow your boat to be operated without the proper use of the ignition safety switch and lanyard.

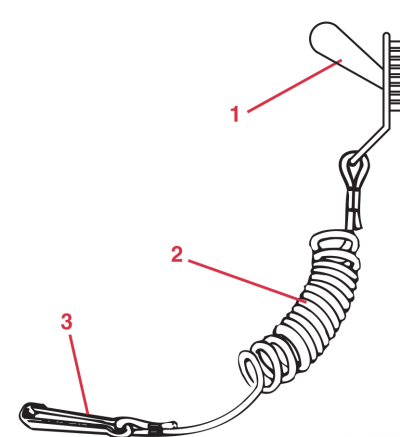

1 – Ignition Safety Switch  
2 – Lanyard  
3 – Hook

Your Cobalt boat is equipped with an ignition emergency safety switch located on the lower edge of the helm. The ignition emergency safety switch, attached by a lanyard, will stop the engine in case of an emergency, when used properly and as directed. Attach the lanyard to the boat operator's clothing

whenever the engine is running, but be aware there will be a loss of boat control if the switch is activated. If the operator is thrown from the seat or moves too far from the helm, the lanyard will become disconnected from the ignition emergency safety switch, shutting off the engine.

To reset the switch after activation, reinstall the lanyard clip and flip the switch to the UP position.

### **DANGER**

The ignition emergency safety switch lanyard should always be connected between the switch and the operator when the engine is running. The purpose of the switch is to immediately shut OFF the engine if the operator moves away from the driver's helm. Without the driver's control, all persons onboard or other boaters in the area could be subject to serious injury or even death. Never operate the boat without the emergency engine stop switch lanyard connected between the switch and the boat operator. Cobalt recommends the operator of the vessel always remain at the helm any time the engine is running.

### **DANGER**

The ignition emergency safety switch can only be effective when it is in good working condition. Observe the following:

- Do not remove or modify the ignition emergency safety switch and/or lanyard.
- The lanyard must be free from obstructions that could interfere with its operation.
- DO NOT operate the boat if the ignition emergency safety switch does not function properly.
- Attach the ignition emergency safety switch lanyard to a secure place on your clothing or person while operating.
- DO NOT attach the lanyard to clothing that could tear loose. DO NOT route the lanyard where it could become entangled, preventing it from functioning.
- Avoid accidentally pulling the lanyard during normal operation. Loss of engine power means loss of most steering control. Also, without engine power, the boat could slow rapidly. This could cause occupants and objects in the boat to dislodge, which could result in serious injury or even death.



## Tilt Steering Release Lever

This lever allows the operator to adjust the steering



wheel to the most comfortable angle and provide a sense of secure control. Steering columns have a lever at the underside of the column. Press down on the lever until the steering wheel is movable. Tilt it up or down to the best angle for the operator and re-engage the lever snug against the steering column. Never force the lever. If it will not move with relative ease back into place, the steering wheel is not in one of its acceptable levels. Adjusting slightly should allow proper action of the tilt mechanism.

### **WARNING**

Adjust the steering wheel only when the boat is not moving. If necessary, slow to idle to make adjustments. Attempting to adjust the tilt mechanism while the boat is in motion could cause the operator to lose control of the vessel.



## Engine Alarm

Your Cobalt boat may be equipped with a warning system that will sound an alarm if an engine problem develops. The horn may emit a short chirping sound during starting to verify operation. If the warning horn sounds when operating the boat, **IMMEDIATELY** throttle back to idle speed and shift into the **NEUTRAL** position. **IMMEDIATELY** check the gauges and stop the engine.

### **NOTICE**

Continued operation after the warning alarm has sounded may cause severe engine damage.

# BASIC FUNCTION FEATURES

## Engine Hatch

This switch operates the electric motor box assembly. Do not continue to operate the switch when the motor box is closed or fully open as it can cause the system to fail. Lower the motor box support after the motor box is opened. Be sure to return the support to its stowed position before lowering the box.

The motor box switch is located in the **aft starboard speaker tub**.



## Ski Tow Eye/Pylon

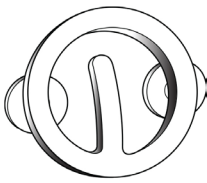

COB\_0245\_A

The stainless-steel ski tow and stainless-steel ski tow pylon are designed for a single skier only. The ski tow pylon is normally located at the stern of the boat or on the ski tower.



**WARNING**

**DO NOT** overload the ski tow, ski tow eye or the ski tow pylon, or use them for anything other than water sports. The ski tow eye and the ski tow pylon maximum load is 1,000 lbs (454 kg).



**WARNING**

**DO NOT** allow passengers to sit behind the pylon whenever someone in the water is being towed. When the towed individual lets loose of the ski/wakeboard rope, the tension may cause the rope and its tow handle to snap back into the deck area. Individuals may not be able to deflect the rope, with the result that people hit by the rope and handle could be injured, especially if they are not paying attention.



**WARNING**

**Tow point failure can result in serious injury or death. DO NOT** attach tubes, inflatables, toys, vessels, etc., to this tow point. **Only use this water sports tow point for single-person skiing, wakeboarding, and wake surfing, etc. DO NOT** attempt to use the pylon for any purpose other than towing individuals behind the boat with an appropriate towing rope. **DO NOT** attempt to tow another boat by attaching a rope to the pylon. **This will overload the pylons and can cause damage to the boat which will not be covered under warranty.**

See also information regarding the use of arches/towers elsewhere in this section of the owner's manual, and in the *Safety* section.

## Tie-Down Locations

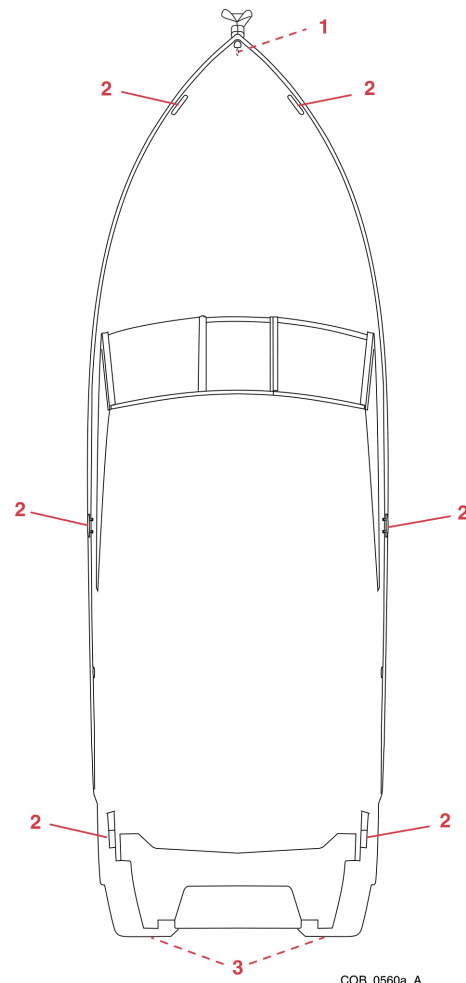

COB\_0560a\_A

- 1 - Bow Eye
- 2 - Cleats
- 3 - Stern Eyes

Tie-down locations are for keeping a Cobalt boat secured when moored. The bow eye and/or stern eyes can also be used. Refer to *Anchoring*, in this owner's manual.

Several methods of securing boats to shoreline and docks are available.

Although Cobalt does not provide rope for tie-ups as a standard provision, dock lines are available through many marine retailers.

Without guarantee, Cobalt recommends a two-strand nylon rope. (Three-strand rope may stretch too much and allow the boat to bump other objects.)

There are several different knots and hitches to secure boats to docks or shoreline. Cobalt recommends making the effort to learn these marine-intended knots and hitches. Consult with your authorized Cobalt dealer to determine which ones will work best in the tie-up application you will be using.



Some hitches are intended for only short-term docking, while others work better for longer periods of inactivity. Always bear in mind wave action may cause the boat to bump the shoreline (and scratch the hull, which is not covered under warranty), or bump against a dock, or even potentially other boats (also not covered under warranty), when selecting the appropriate method to secure the boat.



## Bow Eye and Transom Eyes

All boats are equipped with a single bow eye near the apex of the hull under the bow, and two transom eyes, which are located one each on the port and starboard sides of the transom. The semi-circular or U-shaped metal connections are made from stainless steel to reduce the effects of rust and corrosion. No other part of the boat, including any interior components such as the windshield extrusions or grab handles should ever be used.

### NOTICE

**Never tie up the boat, even temporarily, using any component of the boat except the bow eye, transom eyes and/or cleats (where equipped). Using any other component could result in damage to the boat that is not covered under warranty.**



## Cleats

Cleats are located near the bow on each side of the deck, mid-ship, and near both rear sides.

Although there are multiple marine knots, the cleat hitch is a special knot used to tie the rope to a cleat. If a line is not correctly secured on the cleat using a cleat hitch, it can work loose.

Cleats have two “horns” around which the line is tied. Begin by bringing the line past the center of the cleat on the outside beneath and wrap it around under both horns. Then bring the line across and back under the first horn again in a figure-eight. Make another figure-eight loop around the second horn.

### ⚠ WARNING

**Cleats are used to tie the boat to a dock or to hang fenders. They are not designed for any kind of towing, including other boats. Nor should they be used for anchoring, mooring or lifting the boat; the only locations structurally certified for such “strong point” requirements are the bow and stern eyes. Abuse of the cleats is likely to result in equipment failure that will damage the boat, which is not covered under warranty, and can also result in serious injury or death.**



### NOTICE

**Cobalt recommends the purchase and use of fenders to protect the boat’s gel coat finish whenever a boat is at risk of contact with docks or any other object (for example, rafting up with other boats) that may damage the finish. This kind of damage is not covered under warranty.**

If the boat will be moored for an extended period or where there is active wave motion, Cobalt recommends the purchase of fenders, also available from reputable marine suppliers. Fenders come in a range of sizes and materials, with the goal to protect the boat from damage because of motion against the dock.

### ⚠ WARNING

**Never anchor a boat from the stern. Keep the boat headed into waves.**



# ON AND UNDER THE WATER

Beneath the boat are several critical components for the proper and safe operation of the boat. In general, consumers do not have to give these items attention beyond routine checks and maintenance, but if any of them are damaged, it can result in a truncated outing.

## Propeller

Different conditions, including altitude or specific characteristics of individual bodies of water can impact boating enjoyment. If environmental conditions are suspected of negatively impacting performance, discuss this with an authorized Cobalt dealer, who may be able to recommend minor changes to the propeller, or replacement of a propeller at the consumer's choice and expense, that will improve circumstances for that application. **There are limits to changes that are approved by Cobalt engineers.** Changes that exceed those standards will void the warranty. Extreme changes can also alter the safe handling of the boat and its maneuverability.

### NOTICE

Consumers may choose to change characteristics of propellers or even replace them. Cobalt recommends doing so only after consulting with an authorized Cobalt dealer as exceeding Cobalt standards for the propulsion system will void the warranty.

### WARNING

Care must be taken to avoid being in the water forward or aft of the boat when the engine is running, even if the boat is not in a moving gear. If the shifter/throttle goes into gear, there may not be time to get out of the way of the propeller. Boat drifting can also put individuals in harm's way. Propeller edges are sharp. With motion, propellers can maim or become lethal.



## Reboarding Methods

Depending on the specific boat, the means of reboarding from the water may be by use of a ladder, flip-down step, or swim platform that is close to the water and the person can climb aboard. Refer to appropriate instructions on each application for more information. If you have questions, contact your Cobalt dealer.



## Swim Platform and Ladder

Certain Cobalt models are equipped with a swim platform and ladder. The swim platform provides addi-



tional enjoyment of the Cobalt experience. While the swim platform, along with the optional flip-down step, can ease movement in and out of the water, Cobalt reminds users to exercise caution. When jumping off the boat, always be certain that there is sufficient depth. Appearances can be deceptive, especially in clear water. When using the ladders, use the steps with care to avoid slipping or falling.

Although the swim platform is constructed with anti-skid properties, it is still the responsibility of users to exercise care when walking on it, using it to get onboard, using it to get into the cockpit, standing or sitting on the swim board.

As noted, multiple times throughout this owner's manual, never allow anyone to be on the swim platform when the engine is running, due to exhaust fumes.

### WARNING

Care should always be taken when entering or exiting the boat. The flip step is the recommended egress when the boat is launched in water, and it should be used **ONLY** when the boat is stopped, and the engine is OFF. Using the gunwales for egress is highly discouraged under any circumstances.

### WARNING

Exercise care when deploying the flip step. Under no circumstances should anyone be standing, sitting, or laying on the step while it is in operation. In addition to

possibly damaging equipment, persons on the flip step are subject to serious injury from pinching or falling. Prior to operating the flip step, the user needs to confirm that everyone's hands or feet are clear of the step's mechanical components.



Never allow anyone to be on the swim platform or flip step when the engine is running. Carbon monoxide fumes are colorless and odorless. Illness and/or death are likely from breathing fumes, even before a person is aware of exposure. See the Safety section of this owner's manual for more information regarding this critical matter.



Care must be taken to avoid being in the water forward or aft of the boat when the engine is running, even if the boat is not in a moving gear. If the shifter/throttle goes into gear, there may not be time to get out of the way of the propeller. Boat drifting can also put individuals in harm's way. Propeller edges are sharp. With motion, propellers can maim or become lethal.



## Swim Step—Flip Down

The optional flip-down step can ease movement in and out of the water, but users should exercise caution with its use. When using the step take care to avoid slipping or falling. Be certain the optional flip step is properly stowed before operating the boat. The flip step should be down (and usable) only when the boat is anchored or stationary.

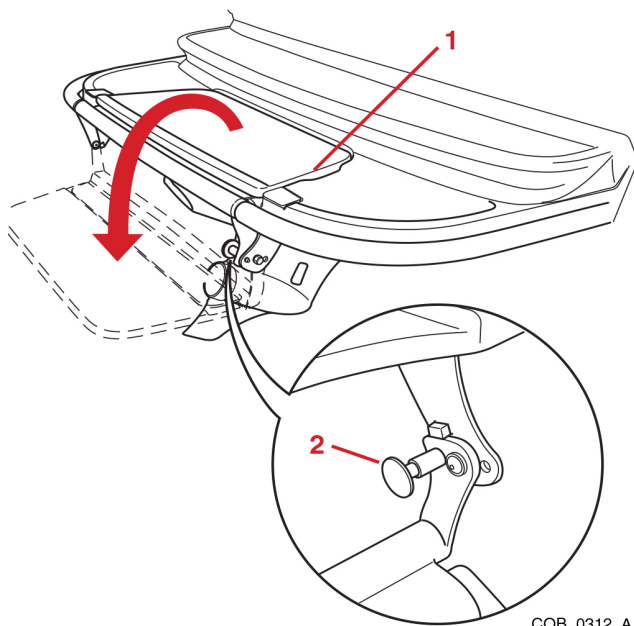

COB\_0312\_A

- 1 – Swim Step
- 2 – Plunger

## Boat in the Water

Lower the drive all the way.

*To deploy the step:*

1. Pull the plunger out and pull up on the front of the step at the same time.
2. Pull the step over into the water. The step will be buoyant.
3. Push the step down; it will automatically lock into place.

*To raise the step:*

1. Push down slightly on the step with your feet while sitting on the platform.
2. Pull the plunger and allow the step to float up.
3. Move to the side and pull the step onto the platform. It will automatically lock into place.

## Boat on a Trailer

Lower the drive as low as possible without hitting the ground or trailer.

*To deploy the step:*

1. Stand behind the platform; pull the plunger out and pull up on the front of the step at the same time.
2. Pull the step towards you; do not let go.
3. Gently let the step down; it will lock into place automatically.

*To raise the step:*

1. Pull the plunger and raise the step at the same time. Be careful when folding the step over onto the platform. Do not allow the step to slam down.
2. Always make sure the area in the platform is clear before closing the step.



**DO NOT** overload the flip down swim step. The swim step maximum load is 400 lbs (181 kg).



The flip step must be in the stowed position whenever the boat is underway.



Care should always be taken when entering or exiting the boat. The flip step is the recommended egress when the boat is launched in water, and it should be used **ONLY** when the boat is stopped, and the engine is OFF. Using the gunwales for egress is highly discouraged under any circumstances.



Exercise care when deploying the flip step. Under no circumstances should anyone be standing, sitting, or laying on the step while it is in operation. In addition to possibly damaging equipment, persons on the flip step are subject to serious injury from pinching or falling. Prior to operating the flip step, the user needs to confirm that everyone's hands or feet are clear of the step's mechanical components.



**! DANGER**

Never allow anyone to be on the swim platform or flip step when the engine is running. Carbon monoxide fumes are colorless and odorless. Illness and/or death are likely from breathing fumes, even before a person is aware of exposure. See the Safety section of this owner's manual for more information regarding this critical matter.

**! DANGER**

Care must be taken to avoid being in the water forward or aft of the boat when the engine is running, even if the boat is not in a moving gear. If the shifter/throttle goes into gear, there may not be time to get out of the way of the propeller. Boat drifting can also put individuals in harm's way. Propeller edges are sharp. With motion, propellers can maim or become lethal.



### E-Step—Flip Down

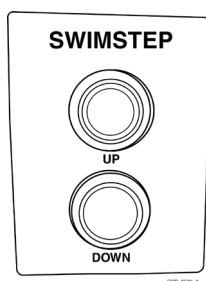

#### Boat in the Water

Lower the drive all the way.  
To deploy the step:

1. Sit or kneel by the sun pad to reach the button switches.
2. Make sure your feet are clear from the step.
3. Press and hold the **DOWN** switch until the step is fully deployed.

To raise the step:

1. Make sure no obstructions are in the way of the step.
2. Press and hold the **UP** switch until the step has been fully closed.

To deploy the step manually:

1. Stand behind the platform; pull the plunger out and pull up on the front of the step at the same time.
2. Pull the step towards you; do not let go.
3. Gently let the step down.

To raise the step manually:

Pull the plunger and raise the step at the same time. Be careful when folding the step over onto the platform. Do not allow the step to slam down. Always make sure the area in the platform is clear before closing the step.

Note: The step locks to the initial position only. If you plan to use the step manually, make sure that the step starts in the closed position. If the actuator fails, the actuator can be detached, and the holding bolt can be locked in place on the designated threaded spot.



### Volvo Penta Ocean Series Outdrive—Optional

Your boat may be equipped with an Ocean Series Outdrive from Volvo Penta. In addition to a composite outdrive, there is a Neutra-Salt switch located in the helm area of your Cobalt boat. Please refer to the *Neutra-Salt Operator's Manual* located in your new owner's packet for operating information.

## PERFORMANCE BOOSTS

### Cruise Control—Optional

**! WARNING**

**DO NOT** use the cruise control feature as a means for navigation or for “no hands” operation.

To operate the Cruise Control speed control system, prepare to set when the boat gets to the desired speed. After the boat reaches the set speed, the Cruise Control will hold the speed constant. For additional operating information, refer to the Cruise Control operator's manual in the owner's packet.



### Wake Surf Controls

To access the surf controls:

1. On either screen, tap the **HOME** button.
2. Select the **A/V GAUGES CONTROLS** button.
3. Tap the **SURF CONROLS** button.

The Wake Surf Controls screen displays.

The Wake Surf controls may also be accessed via the **Smart Mode** screens. Refer to *Glass Cockpit Dash Unit* instruction previously shared in this section.

Functions that are performed in any mode:

At 14 miles per hour, surf gates will fully retract, and the operation will be disabled until the speed drops back below 13 miles per hour.

If communication GPS speed is lost, the **SURF LEFT** and **SURF RIGHT** lights will flash. (**SURF LEFT** and **SURF**





**RIGHT** operations are explained further in this section.) The system will act as if the boat is over 14 miles per hour until the GPS speed communication is re-established. This will happen if the GPS signal is blocked by obstructions such as roofs or buildings.

If communication with the engine is lost, the **Performance** and **Trailer/Hoist** lights will flash. **Performance**, **SURF LEFT** and **SURF RIGHT** will be disabled.

If there is an overcurrent or if the controller detects a failure in the control of the Surf Tabs, the **Check Surf System** indicator light will flash. If this happens, proceed with caution as the surf gates are in an unknown position and can cause excessive boat angles at speeds over 14 MPH. The system can be reset by cycling the ignition key to the **OFF** position, waiting for the boat to power down, and then keying back **ON**.

#### *Manual Mode:*

The system always powers up in *Manual* mode. If no other mode is active, the system will be in *Manual* mode.

In this mode, there is no automatic movement other than the 14-mile-per-hour threshold that will cause the gates to retract.

#### *Ballast Tank Operation:*

Open all seacocks. (There are two or three depending on the model.) To fill the ballast tanks with water, select the corresponding tank switch to **FILL**.

The pump will automatically shut off when the tank is full. The pump will run, after full float is activated, for an extended amount of time, depending on the tank.

To add more water to the tank after the pump has shut off, select **FILL**. The pump will run for an extended

time and then automatically turn off.

To empty the ballast tanks, move the corresponding switch to **EMPTY**.

The pump will automatically shut off when the tank is empty. To remove more water from the tank, select **EMPTY**. The pump will run for an extended time and then automatically turn off.

Turn off the pumps at any point by selecting **EMPTY** or **FILL** a second time. There is a **FULL**, **1/2**, and **1/8** LED indicator for each tank. The tank is empty when the 1/8 indicator light turns off. If the LED indicators do not operate, it can mean that the system is not working. Do not leave the pump(s) running if water is not emptying or filling as expected, as it can cause damage to the pump that is not covered under warranty.

If the system is not working as designed, see an authorized Cobalt dealer as soon as possible.

#### *Wake Surf Operation:*

##### **Surf Left:**

When the operator presses and releases the **SURF LEFT** momentary switch, the system will enter the **SURF LEFT** mode, if the GPS speed is less than 13 miles per hour. The **SURF LEFT** indicator light blinks while the surf gates, trim tabs, and engine trim move.

After the surf gates and engine trim have stopped moving, the **SURF LEFT** indicator light is solid until the next movement is commanded. The **SURF LEFT** mode stays active until the **SURF LEFT** button is pressed again, or another mode is selected.

The following sequence is initialized:

1. **SURF LEFT** indicator light begins flashing.
2. Engine trim goes into surf position.
3. Trim tabs retract.
4. If speed is between 8-14 mph:
  - Right surf gate extends.
  - Left surf gate retracts.
  - **SURF LEFT** indicator light becomes solid until a new mode is selected or further movement of the surf gates or the engine trim is commanded.
5. After GPS speed reaches 14 miles per hour, both surf gates are retracted.
6. After GPS speed drops below 13 miles per hour, the system re-initiates, placing the surf gate and engine trim back into **SURF LEFT** position.
7. After GPS speed drops below 8 miles per hour, both surf gates retract.



8. **SURF LEFT** button pushed a second time will cause both surf gates to fully retract. At this point the system moves into Manual mode.

**Surf Right:**

When the operator presses and releases the **SURF RIGHT** momentary switch, the system will enter the **SURF RIGHT** mode, if the GPS speed is less than 13 miles per hour. The **SURF RIGHT** indicator light blinks while the surf gates, trim tabs, and engine trim move.

After the surf gates and engine trim have stopped moving, the **SURF RIGHT** indicator light is solid until the next movement is commanded. The **SURF RIGHT** mode stays active until the **SURF RIGHT** button is pressed again, or another mode is selected.

The following sequence is initialized:

1. **SURF RIGHT** indicator light begins flashing.
2. Engine trim goes into surf position.
3. Trim tabs retract.
4. If speed is between 8-14 mph:
  - Right surf gate extends.
  - Left surf gate retracts.
  - **SURF RIGHT** indicator light becomes solid until a new mode is selected or further movement of the surf gates or the engine trim is commanded.
5. After GPS speed reaches 14 miles per hour, both surf gates are retracted.
6. After GPS speed drops below 13 miles per hour, the system re-initiates, placing the surf gate and engine trim back into **SURF RIGHT** position.
7. After GPS speed drops below 8 miles per hour, both surf gates retract.
8. **SURF LEFT** button pushed a second time will cause both surf gates to fully retract. At this point, the system moves into *Manual* mode.

*Performance Mode:*

When the operator presses and releases the **Performance** momentary switch, the system will enter the **Performance** mode. The **Performance** indicator light blinks while surf gates, trim tabs, and the engine trim move. After the surf gates, trim tabs, and engine trim have stopped moving, the **Performance** indicator light is solid until the next movement is commanded. The **Performance** mode stays active until the **Performance** button is pressed again, or another mode is selected.

*The following sequence is initialized:*

1. Outdrive trim is commanded all the way down.
2. Surf gates are fully retracted.
3. If the speed is below 8 miles per hour, the trim tabs will fully extend.
4. The trim tabs will automatically retract, based on the boat speed.

5. When the speed drops below 8 miles per hour, the system will reset to Step 1.

*Trailer/Hoist Mode:*

When the operator presses and releases the **Trailer/Hoist** momentary switch, the system will enter the **Trailer/Hoist** mode. The **Performance** indicator light blinks while surf gates, and trim tabs move. After the surf gates and trim tabs have stopped moving, the **Trailer/Hoist** indicator light is solid until the next movement is commanded. The **Trailer/Hoist** mode stays active until the **Trailer/Hoist** button is pressed again or another mode is selected.

*The following sequence is initialized:*

1. Both left and right surf gates and trim tabs are fully retracted, and extend movement is disabled.
2. All three ballast tanks are emptied. Ballast switches are disabled while in this mode. Pumps will automatically turn off when the tanks are emptied.



**Motor Box Assembly or Electric Motor Box Assembly**



**DO NOT** occupy or operate an engine when the motor box is open. The motor box assembly is a machinery guard.



**The motor cover is substantial and may require more than one person to lift. When lifting the box manually, position one person at each grab handle and lift straight up and then place the support into position.**

Do not operate the motor box assembly if the ski tow is installed. Damage to the motor box, hinges, ski tow and lifting unit can result. Before opening the motor box, make sure the ski tow is removed, no items are on top of the motor box, and cushions, inserts or stored equipment are secure or removed.

Use the motor box support, which is internally attached, to brace the box after it is open. Be sure to return the support back to the stow position and clear any obstructions before closing the box. Wind and conditions may allow the motor box to open beyond its intended opening; use caution during these conditions.

The electric motor box assembly is controlled by its switch. In the event of battery failure or storage, the motor box can be opened manually.



## Battery Switch

The dual battery switch provides isolation and positive disconnect from the batteries to protect against tampering, electrical fire hazards and battery rundown. The switch should normally be in the **ON** position rather than the **COMBINE BATTERIES** position. In the **OFF** position, the boat will be isolated from the batteries except for the items requiring constant power such as the bilge pump.

### NOTICE

**COMBINE BATTERIES** position should be used only for emergency start.

### NOTICE

On dual battery installations, there is an Automatic Charging Relay (ACR) installed that allows the engine to charge the house battery. The ACR is intended to keep a load from discharging both of the batteries.

## Automatic Charging Relay (ACR)

On boats equipped with two batteries, the automatic charging relay (ACR) automatically combines the batteries when the engine is running. It also isolates the batteries when discharging to prevent the starting battery from then discharging while using the house battery when the engine is off. The ACR has the following features:

- 120-amp continuous rating
- 12/24V DC auto ranging voltage input
- Senses charging on two battery banks
- Side and bottom knockouts for cable connections
- Clip-on cover insulates terminal connections

- Integrated LED indicates ACR status
- Waterproof-rated IP67 for temporary immersion

## Battery Charger—Optional

See specific operating instructions located in the boat new owner's packet or consult your Cobalt dealer for further information. **DO NOT** use any battery charger not specified by Cobalt for use on Cobalt boats. Some chargers are not intended for use in marine environment and can result in shock hazard. Other chargers may not provide sufficient boost. Never use an automotive battery charger or attempt to "jump" the boat's batteries as can be done with land vehicles.

## Transom Tilt Switch—Optional

The remote transom tilt switch allows the drive unit to be raised or lowered from the stern. The remote tilt switch is connected directly to the battery switch and does not require the ignition key to be **ON**. If the boat has twin engines, each drive unit will have a switch.

## Tool Kit—Optional

Unanticipated issues can arise during an outing. To be prepared for minor mechanical and electrical problems an optional tool kit holds the most-likely tools to be needed. For the location of the tool kit, refer to *Specifications*.



## COMFORT AND ENHANCEMENTS



### Seating

Cobalt provides seating to increase your boating pleasure. The standard seating is crafted from top-quality materials and engineered to provide the maximum-allowed number of individuals onboard for the boat model's design. Please note that it is very important for passengers to be seated when the boat is underway as shown in the seating information in *Specifications* in this owner's manual. This provides for balance and avoidance of over-loading that could otherwise adversely affect the boat's maneuverability, swamp the boat, or even cause injury or death.

#### DANGER

Failure to evenly distribute the combination of passengers and additional gear brought onboard can result in loss of control of the boat, swamping and sinking, and causing other adverse effects. Never exceed the boat capacity, paying particular attention to limits in bow seating. Failure to pay on-going attention to this can result in serious injury or death.

#### WARNING

Never attempt to jump into the body of water from any of the seating in the boat. It can be difficult to determine water depth, and it could be possible to misjudge clearance of the deck and gunwales.



Transom seating is intended for use only when the boat is fully stopped, without the engine running. Sitting in this area while the boat is underway could result in individuals falling off, which could result in injury or even death. It is also possible that carbon monoxide fumes from the exhaust system could reach individuals sitting here.

No one should sit or ride on the sun pads when the boat engine is running. Carbon monoxide is emitted from the exhaust system and vented into the water beneath the transom. Fumes can and do reach the sun pad area. Avoidance of carbon monoxide poisoning is addressed in the *Safety* section of this manual.

#### WARNING

The transom seating should never be used while the boat is underway as passengers in those seats could be dislodged, resulting in injury or death. Also, the seat should never be used when the engine is running because passengers at the transom may also be subject to carbon monoxide fumes emitted from the engine(s). Do not have the engine(s) running while passengers are sitting in the transom seats. Even while stationary, the transom seats should never be the location from which individuals attempt to leap into the water. It can be difficult to determine the water depth, and people can misjudge clearance of the deck and gunwales or transom.

#### WARNING

Interior grab handles may be used by passengers to hold on to during boat operation. The handles are sturdy surfaces, which means that if an individual makes sharp contact with a grab handle, bruising may result. If the boat is being operated in a manner that results in excessive movement of the passengers, or if people are shoving each other, even playfully, at any time, injury is possible. Cobalt strongly recommends that this kind of activity always be avoided. Do not use the handles to secure or tie up the boat as this can cause damage that is not covered by warranty.

When adjusting the helm seat, note that there is a handle pull inboard, adjacent to the glide handle. Pull the upper lever inboard to unlock the slide mechanism. When in the neutral position, the driver can slide the seat forward or aft to a preferred position. Return the handle to its locked position while the boat is underway. Failure to do so could cause the seat to move, resulting in the driver losing control.

The driver's seat also has a swivel feature. To activate, pull the lower lever inboard to unlock the swivel mechanism. When the desired position has been achieved, release the handle to lock the position. There



are also optional features for the helm seat, which are explained immediately following.

It is critical to the long-term use and enjoyment of the boat to perform the routine maintenance required to keep all interior upholstery in top condition.

**! WARNING**

Several seating backs and/or cushions are adjustable or movable. These features operate with latches and slides. Care should always be taken to avoid pinching skin or limbs when moving components of the seating. Ensure that the various moving parts have locked into place before use. Otherwise, these components could move when people are not expecting motion, and that could result in accidentally shifting individuals.



### Captain's Chair Adjustments and Operation

The captain's chair has a flip-up position for greater visibility and maneuverability while docking. You can sit on the raised cushion or stand in front of the cushion.

Standing while driving your boat should be done only by an experienced driver while maneuvering at an idle speed or when required for visibility.

The chairs are adjustable fore and aft, and also rotate. Some fore and aft adjustment may be necessary when swiveling the seat(s) to avoid damage to the chair or side panel. Some seating configures do not allow all seats to rotate completely.

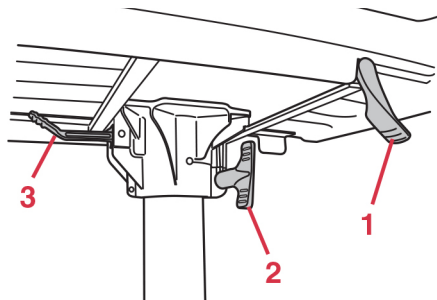

COB\_0093\_A

Lift the lever to adjust the seat fore and aft. Turn the rotation friction handle clockwise to increase friction, and counterclockwise to decrease friction. The chair should always be operated with slight friction.

Move the chair slightly forward, then lift the rotation lever to adjust. The lever will rest in its detent when the seat is in its forward direction.

**! DANGER**

**DO NOT stand while driving above engine idle speeds unless required for visibility, and make sure all passengers are seated and seats are in a locked/secured position when the boat is underway. Situations may arise while underway that could cause the operator to lose footing and fall or step away from the helm, which may result in loss of control of the vessel.**



### Helm Seat Electric Slide Operation—Optional

#### How to Use the Electric Slide Operation for the Helm Seat

There are two rocker switches located on the side panel. The switch with left and right arrows controls movement forward and backward. The switch with up and down arrows controls the height above deck.

*To move forward and backward:*

- Press and hold the rocker switch in the forward (left arrow) position to move the helm seat forward.
- Press and hold the rocker switch in the aft (right arrow) position to move the helm seat backward.

To move the seat up or down to adjust the height of the seat in relation to the deck:

- Press and hold the rocker switch in the **UP** position to raise the helm seat.
- Press and hold the rocker switch in the **DOWN** position to lower the helm seat.

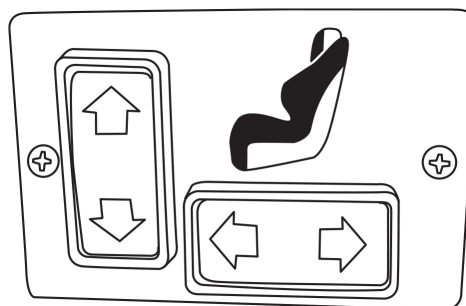

**! DANGER**

**Above engine idle speeds, make sure all passengers are seated and seats are in a locked/secured position when the boat is underway.**



## Removable Bow Filler Cushion—Optional

Additional bow seating can be added by inserting the bow filler cushion. Place the cushion into position by sliding the cushion support under the bow seat, then slide the bow cushion in and push into position. When not in use, store the bow filler cushion and support in a clean and dry location.



## Glove Box

Cobalt recommends storing this manual in the glove box so that it will always be readily available for reference during outings. Placing this manual in a plastic bag will increase its protection.

The glove box is convenient for storing personal items while boating, as well. While the glove box is not waterproof, its design reduces the likelihood of damage from water that may come onboard. Cobalt does not warrant the level of water resistance available when using the glove box.



The glove box opens by pushing on the button on the front of the lid. Closing requires only shutting the lid tight. Closing requires minimal effort. If more effort is required, it is likely the glove box is overloaded, and some material should be removed prior to closing.

## Do not store any aerosol items in the glove box.

These can overheat and leak and/or rupture. Any liquid or semi-liquid material placed in the glove box may spill or overheat. Care should always be used when placing liquids such as suntan lotion in the glove box. Cobalt is not responsible for such misjudgments.

If any water intrudes into the glove box, clean it out as soon as practical. Mold and mildew can result if even small amounts of water are not removed. As with any storage location, any spills should be cleaned efficiently to avoid damage and/or odors.

## NOTICE

**Never attempt to close an overloaded glove box. Trying to force the lid closed could result in damage that is not covered under warranty. Avoid pinching fingers, hands, and other body parts while closing the glove box lid.**



## Storage Compartments

Cobalt boats have multiple storage compartments available throughout the boat. In general, storage is available in the bow, gunwale, and floor. Some models will also have transom storage and may have interior lighting within the storage compartments.



As much as possible, gear and property brought onboard should be stowed in storage compartments to prevent movement of items during the outing. Unsecured items could strike and potentially injure individuals onboard during operation.

Be sure to distribute items throughout the boat and compensate for the weight of persons onboard. Weight should be as evenly distributed throughout the boat as possible to avoid negatively affecting control. Never try to close an overloaded storage compartment. Forcing a compartment closed can result in damage to the boat that is not covered under warranty.



Storage compartments should be cleaned out in accordance with the instructions in this manual. At least annually, all compartments require thorough cleaning. If anything with residual odor is placed in a storage compartment, or if anything has spilled in the compartment, cleaning should be done as quickly as possible afterwards.

**! DANGER**

Anything brought onboard should be stored in a designated storage compartment, if possible, to avoid the potential of individuals being struck by an unsecured item while underway. This could result in serious injury or even death. Items should be evenly distributed and with attention to the number of passengers and where they will sit. Even distribution of added weight is critical to a safe operation.



Never force a compartment closed as overloading could cause damage to the boat and that is not covered under warranty.



## Cup Holders

All boats are equipped with cup holders. The cup holders are sized for contemporary, normal-sized cups. Cobalt recommends using only cups with covers as boat motion is likely to otherwise slosh liquids out of the cups. If liquids are spilled into the cup holder, or anywhere else, they should be cleaned up as soon as practical to prevent any damage to the boat components or anything brought onboard. Such damage is not covered under warranty.



## Windshield

The Cobalt windshield can be opened to allow easier access to the bow area and greater air flow. To open the windshield, ensure the vertical slots in the mechanism are aligned. Swing the windshield open until the windshield

post falls into the vertical slots and the mechanism locks.

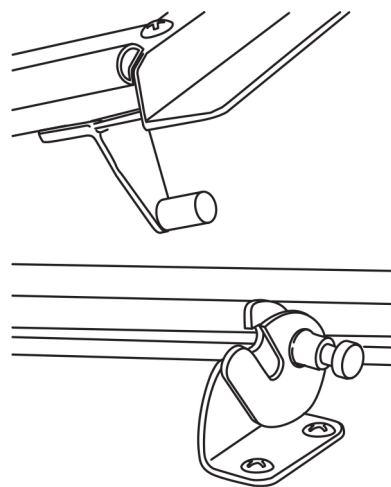

COB\_0096\_A

To close the windshield, release the locking mechanism by pulling the forward-facing button. Swing the windshield into the closed position.

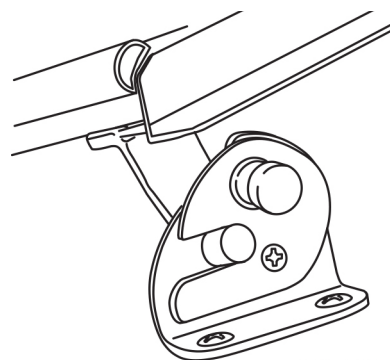

COB\_0095\_A

**! CAUTION**

In the process of opening or closing the windshield, care should be taken to avoid pinching fingers, hands or any body parts between windshield sections. Injury may result.



## Cockpit Dinette Table—Optional

Cobalt boats may be equipped with a cockpit table. Unless the table is locked into place, it should be stowed to avoid potentially having parts of it become projectiles during boat operation.

To enjoy the convenience of the table, remove the J-shaped table leg from the **starboard bow storage area**. Slide the leg into its mounting support. Slide the tabletop onto the leg. If the tabletop has a lever, tighten the lever.

Your optional dinette table may include teak as one of the materials. Teak has been chosen because of its durability, especially in wet conditions. However, to keep teak in top condition, clean it occasionally with a teak cleaner and re-oil it at least once a season. **Do not use**



any other type of cleaner as it may cause damage to the table finish. Note that all wood eventually deteriorates in the presence of damp or wet conditions, but keeping the table pieces re-oiled annually will significantly lengthen the life of the table's finish.



## Cooler

As a convenience, your Cobalt boat is equipped with a cooler. Ice can be manually added with beverages and food, and it will keep items cooled for several hours, as long as the cooler remains closed.



### NOTICE

Any remaining ice or melt should be disposed of at the conclusion of the outing. Contents should also be removed. Allowing liquid to remain undrained will lead to damaging mold and mildew. Food items will spoil, and some will create an odor that cannot be eliminated, even after a thorough cleaning. Spills should also be cleaned up immediately after the outing as food and drink can permanently stain the cooler. No claims are made about stain resistance, regardless of how quickly the spillage is cleaned. Damages from misuse of the cooler are not covered under warranty.



## Entertainment System

To operate your entertainment system, you must first supply power to the unit(s). Make sure the battery switch is on. If your boat is equipped with a *Power Distribution Panel*, the switches for the entertainment system components must be turned **ON** before operation.

For additional operating information, refer to the operator's manual for your stereo and accessories supplied in the new owner's packet.



The audio speakers in your Cobalt are designed to deliver maximum fidelity in a marine environment. The speakers can be damaged if struck by a sharp object or if the moving elements are restricted from movement. Do not store or place any sharp objects near the speakers or restrict the element's movement.

Some boats are also equipped with a stereo remote control at the transom. Information about its use is contained in additional material provided in the new owner's packet.



## Air Compressor—Optional

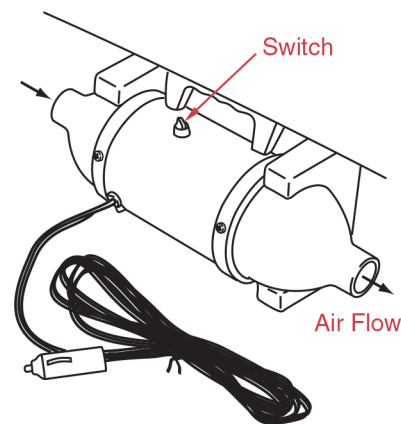

COB\_0101\_A

Where equipped, a high-volume air compressor is conveniently located in the *port-side bench seat storage compartment*. It is used to inflate your favorite water



toys. Plug into the accessory receptacle on the dash or in the air compressor area.

Avoid direct exposure to water as the air compressor is not waterproof and can be damaged. This is not covered under warranty. Keep stowed in a dry location when not in use.



## Anchor Light

To use the anchor light, insert the pole into the socket and turn clockwise until it locks into place.



**Do not put any pressure on the anchor light while it is installed as that could result in bending, breaking or otherwise damaging the light. That is not covered under warranty. Individuals could also be injured.**

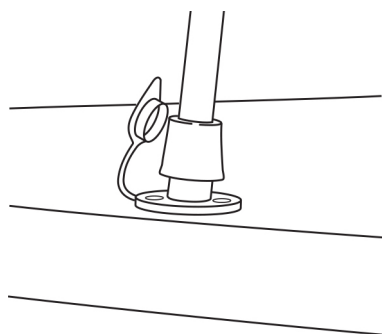

COB\_0097\_A

Close and protect the anchor light socket when the anchor light is removed by closing off the void with the attached cap.



## RGB Lighting Operation—Optional Manual Control

1. Activate the accent and underwater lights (where equipped) by using the dash switches. The dimmer switch is located on the bottom of the dash.
2. When the lights come on, push and release the dimmer switch to make the lights cycle through all the colors. To select a desired color during cycling, push the dimmer switch once to lock on the selected color.
3. To toggle through all the colors, rapidly push the dimmer switch.
4. Pushing and holding the dimmer switch will adjust the brightness of the lighting.
5. If the underwater and accent light switch is turned **OFF**, upon turning **ON** again the lights will default to white and full brightness.



## Control with Garmin

1. Open the **Shadow-Caster Lighting Control** by accessing the Garmin Menu, and swiping left from the right side of the screen. Select the **OneHelm/AV Gauge** option, followed by selecting the **Shadow-Caster** icon to bring up controls.
2. After the **Shadow-Caster** control is open on Garmin, the accent and underwater lights (where equipped) will turn **OFF**; this is normal operation. You must also leave the desired accent or underwater light switches on the dash in the **ON** position to supply power.
3. Control the light settings for the accent and underwater lights through Garmin at this point, changing colors, brightness, and other settings. If at any point the dash switches are turned **OFF** and turned back **ON**, all the lighting will default back to white.
4. If Garmin is shut off, cycling the accent or underwater light switch will change the color to white and restore manual control.



## Fresh Water—Optional

The fresh water system provides potable (drinkable) water to the sink and transom shower. Refer to *Specifications* for the capacity of the water system.



**As standard procedure, the water system is winterized from the factory and water is non-potable. DO NOT DRINK. The system must be cleaned and disinfected before the first use.**

The system is operated by a 12V DC water pump located in the engine compartment. It is necessary for the 12V DC system to be energized and the **WATER PRESSURE** switch to be turned ON to operate the water system.

The water pump works on demand. It will not automatically shut off when the fresh water tank is empty. Monitor the level of water in the tank. If the water pump

is allowed to run continuously, it may overheat. Resulting damage is not covered under warranty. Never leave water in the system between outings as mold and mildew may form in the tank and equipment.

After placing the fresh water system into use, use only potable water. Never mix with water from the boating source, such as a lake or river. To clean and disinfect the water tank, refer to *Water System* (if equipped).

Consult your authorized Cobalt dealer for winterization requirements.



### Shower Water Pressure—Optional

This switch activates the water pressure pump. Water pressure is required for the transom shower. Do not leave the switch on if the shower is not in use as it will eventually cause the pump to fail.



### Marine Toilet (Head) and Macerator—Optional Instructions

Before operating the head for the first time, refer to the marine toilet owner's manual in the new boat owner's packet.

#### Porta Potti

To operate:

1. Depress the bellows pump to fill the bowl with water.
2. To flush, pull out the slide valve handle, located on the front of the unit. Depress the bellows pump one or more times until all waste is removed.
3. Close the slide valve by pushing the handle fully in.

The marine toilet (head) has its own holding tank and can be emptied manually, or if the “pump out” option is installed, the waste can be pumped out through a deck plate fitting marked **WASTE**, or overboard with the optional macerator and where allowed.

#### NOTICE

**For storage or discharge, only liquids should be deposited in the toilet. Toilet paper, sanitary items, food, etc., should be placed in a separate container prepared for this purpose and disposed of in a proper location after the outing. Solid waste can clog the lines of the marine toilet system, causing a backup and potentially hazardous spillage. Many boating bodies of water also restrict waste discharge.**

#### NOTICE

**Overboard discharge of waste should be used only in areas where such discharge is legal. It is the boat owner's/operator's responsibility to comply with local regulations regard-**

**ing the discharge of waste. Having an operable overboard discharge system does not mean that it can be used in spite of specific regulations regarding discharge. You could be significantly fined if the system is used in an unapproved manner. To avoid misuse, lock the “Y” valve in the “pump-out” position when boating in restricted waters.**



### Electrically Operated Head

#### NOTICE

**Avoid damage to the waste system. Do not flush into a full holding tank.**

1. Make sure the inlet seacocks are open.
2. Push the button to operate.
3. Operate until the bowl is completely flushed and the discharge pump has scavenged water from the bottom of the bowl.

The electric marine toilet will provide years of trouble-free service if properly used. It will handle waste and toilet tissue. It will **NOT** handle rags, sanitary items or hard, solid objects. **See the NOTICES in the previous listing regarding restrictions.**

**TROUBLESHOOTING NOTE:** If the bowl does not pump out as it begins to fill, partially close the inlet valve until the bowl is cleared and completely pumped out. Then operate for a few seconds with both valves open to clear the entire toilet and discharge system.

#### NOTICE

**For maximum safety, when the toilet is not in use or the vessel is unattended, close both the inlet and discharge seacocks.**

To drain for winter lay-up, close the inlet valve and operate for a few seconds until all water is pumped out. Do not leave the pump in the **ON** position as it will cause damage to the pump that is not covered under warranty. All water

must be removed from the system prior to storage, particularly during cold weather when residual water could freeze and then damage the system.

After significant periods of non-use, the toilet and pump may dry out. To ease initial start-up, put about one (1) quart (1 L) of water in bowl and let stand before initial use.

With this option, your boat is fitted with a waste holding tank. It is emptied through the deck plate fitting marked **WASTE**. Waste is pumped from the head through a sanitary waste hose to the top portion of the tank. A sanitary waste hose is attached to the bottom of the tank and runs to the dockside pump-out plate. An overboard vent keeps the tank at atmospheric pressure regardless of waste levels.

The optional macerator system allows discharge from the waste tank directly overboard. For additional operating information, refer to the macerator operator's manual. (As noted above, direct discharge **MAY NOT** be allowed. Always verify before discharging.)

All components of the waste system are made of materials specially formulated to prevent odor permeation. It is strongly recommended you regularly add chemicals formulated for recreational products to your tank by flushing it through the head. The chemical helps to control odor and break down the waste. Follow the manufacturer's instructions on the chemical before using. Such chemicals are available through marine distributors, RV suppliers and, in some instances, Cobalt dealers.

**CAUTION**

Never use harsh chemicals that have not been formulated for use in a boat head, as these can cause damage that is not covered under warranty and contact with skin could result in injury.

**Dockside Waste Disposal**

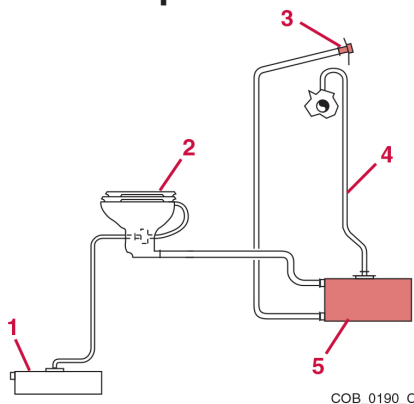

- 1 – Water Tank
- 2 – Head
- 3 – Waste Dockside Pump-out Fitting
- 4 – Vent
- 5 – Holding Tank

**Dockside Pump-Out**

This system directs all waste from the head to the holding tank. To clear the tank, use the dockside pump-out services provided at marinas or other facilities.

To empty the tank, connect the dockside pump suction hose to the **WASTE** pump-out plate. The **WASTE** pump-out plate is always located at a “high point” on the boat. For the **WASTE** pump-out connection, refer to *Water/Plumbing*.

**NOTICE**

Overboard discharge of waste should be used only in areas where such discharge is legal. It is the boat owner's/operator's responsibility to comply with local regulations regarding the discharge of waste. Having an operable overboard discharge system does not mean that it can be used outside of specific regulations regarding discharge. You could be significantly fined if the system is used in an unapproved manner. To avoid a fine, lock the “Y” valve in the “pump-out” position when boating in restricted waters.



**Macerator Pump**

**NOTICE**

Overboard discharge of waste should be used only in areas where such discharge is legal. It is the boat owner's/operator's responsibility to comply with local regulations regarding the discharge of waste. Having an operable overboard discharge system does not mean that it can be used outside of specific regulations regarding discharge. You could be significantly fined if the system is used in an unapproved manner. To avoid a fine, lock the “Y” valve in the “pump-out” position when boating in restricted waters.

**NOTICE**

Avoid damaging the macerator unit. Do not run the macerator dry. Running it when there is no waste will shorten the life of the system.



**Waste Disposal with Optional Macerator**

The optional macerator system allows the discharging of waste directly overboard. Refer to *Water/Plumbing* for component location. For additional operating information refer to the macerator operator's manual supplied with the Cobalt boat.

A “Y” valve is installed in the holding tank outlet hose and permits use of the dockside pump-out feature or to use the macerator to pump the waste from the holding tank overboard.

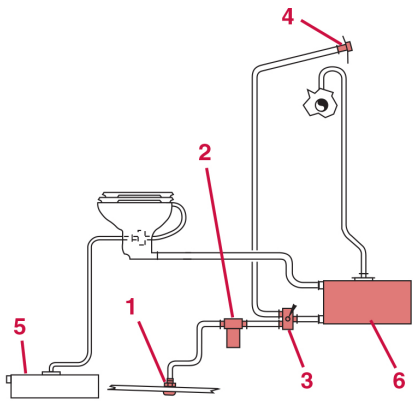

COB\_0189\_C

- 1 – Thru-Hull Discharge Fitting
- 2 – Macerator Pump
- 3 – “Y” Valve
- 4 – Waste Dockside Pump-out Fitting
- 5 – Water Tank
- 6 – Holding Tank

1. To pump out the holding tank using the macerator pump:
2. Move the “Y” valve lever to the **OVERBOARD** position.
3. Activate the macerator pump by turning the switch on.

4. Turn off the macerator pump after the pump-out is complete.
5. Move the “Y” valve lever back to the **PUMP OUT** position.

If your boat is equipped with a tank level monitor, the tank level monitor will illuminate the indicator light to monitor the tank level. If the monitor fails to work properly, seek assistance from an authorized Cobalt dealer. The monitor is critical to determining when the holding tank is becoming too full to continue using without off-loading waste.

### NOTICE

Overboard discharge of waste should be used only in areas where such discharge is legal. It is the boat owner’s/operator’s responsibility to comply with local regulations regarding the discharge of waste. Having an operable overboard discharge system does not mean that it can be used outside of specific regulations regarding discharge. You could be significantly fined if the system is used in an unapproved manner. To avoid a fine, lock the “Y” valve in the “pump-out” position when boating in restricted waters.

## CANVAS AND COVERS

### ⚠ DANGER

Arches and towers are designed to tow a wakeboarder. These components should **NEVER** be used as contact points to tow other boats, tubes, parasails, etc. Such activity could result in component failure that would result in serious injury or death.

### ⚠ WARNING

No components should be added to the Cobalt tower or arch beyond what is specified by Cobalt. Other aftermarket items may not be acceptable due to electrical, electronic, or other wiring and power-related issues. The tower or arch weight limit may also be exceeded by adding aftermarket items. Such weight limits can also cause the tower or arch to fail, which could result in damage that is not covered under warranty, as well as serious injury or death to persons onboard. Never suspend any additional items from the tower or arch. No one should ever be allowed to sit or stand on or hang from the tower or arch. The design will not support such activity and may result in serious injury or death.

### ⚠ WARNING

Never sit or allow others to sit aft of the connection point for a tow rope on a tower or pylon. When the towed individual lets loose of the ski/wakeboard rope, the tension may cause the rope and its tow handle to

snap back into the deck area. Individuals may not be able to deflect the rope, with the result that people hit by the rope and handle could be injured, especially if they are not paying attention.

### ⚠ WARNING

Secure boards and/or skis prior to operating the boat. If they are not secure, the boards and/or skis may become projectiles that could damage the boat or hurt individuals. Remove and stow items in the boat when trailering. Even if secured on the racks, highway speed can cause damage to the boards, skis, tower or boat, or even cause them to become projectiles that can hit other vehicles on the road and cause damage and/or serious injury or death.

### ⚠ CAUTION

Do not allow loose ropes to hang from the tower. In these instances, the ropes may become entangled with drivers, passengers or equipment. Inflatables should **NOT** be towed from the tower. The impact forces exerted by towed inflatables may damage the tower or the hull of the boat.



## Bow Tonneau Cover—Optional

(Before using this component, be sure to read all the **Danger, Warning** and **Caution** statements at the beginning of this section.)

*Follow these procedures to attach the bow tonneau cover:*

1. Open the walk-thru doors.
2. Starting at the forward edge of the bow, slip the tonneau's bow opening over bow, covering to the bow adjacent to the helm, and snap the cover to the boat.
3. Close the windshield center door and snap the canvas to the underside of the windshield.
4. Install the adjustable tonneau cover support pole. Make sure the pole is perpendicular to the floor and adjust to "tent" the cover.
5. Walk-thru doors may be closed, if desired.

### NOTICE

**Do not use the bow tonneau cover for extended storage. It is not designed for storage but can be used for overnight storage or trailering.**

### NOTICE

**Always double-check the snaps are secure.**

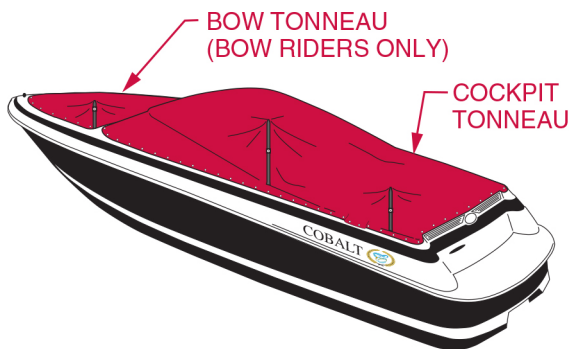

## Cockpit Tonneau Cover—Optional

(Before using this component, be sure to read all the **Danger, Warning** and **Caution** statements at the beginning of this section.)

*Follow these directions for the cockpit tonneau cover:*

1. Unroll the cover and snap to the deck, starting at the center of the windshield. Snap to the forward outside edge of the windshield only.
2. Install tonneau support pole(s) to the underside of the cover (just in front of the rear seat) using the snaps, and adjust the pole(s) to the approximate height of the windshield. Some models have two support poles. Make sure the poles are perpendicular to the floor and adjust to "tent" the cover.
3. Pull elastic cords over the discs on the transom, start-

ing in the center and working outboard (the support poles may require readjustment for proper fit).

4. Continue snapping up the sides.
5. The walk-thru doors may be closed, if desired.

### NOTICE

**Do not use cockpit tonneau cover for extended storage. It is not designed for storage, but can be used for overnight storage or trailering.**

### NOTICE

**Always double-check snaps are secure.**

## Premium Bimini Top with Easy Fold—Optional

(Before using this component, be sure to read all the **Danger, Warning** and **Caution** statements at the beginning of this section.)

### NOTICE

**Do not operate equipment that has loose or missing fasteners. Be sure all fasteners are installed and properly tightened before operating equipment.**

1. Remove the stainless adjustable arms from the storage area.
2. Unfold the top and install the stainless adjustable arms (tensioners) into the quick-disconnect fittings on the deck, forward of the windshield. Secure the forward arms to the forward cross members with the pins.
3. Tighten the Bimini by twisting the tensioners.
4. When the top is up, make sure the light wire is routed correctly and the navigation light is properly secured.

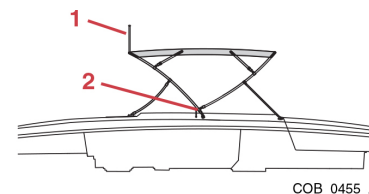

- 1 – Navigation Light
- 2 – Light Wire

5. To assist in laying the Bimini down for storage, there are four (4) knobs and lanyards in the glove box that can be installed instead of the socket-head bolts and slotted screws, if desired. Do not trailer with the Bimini top up. Store and trailer the Bimini top in the stowed position, in its canvas boot.
6. To fold down the Bimini top, release the port side lever.

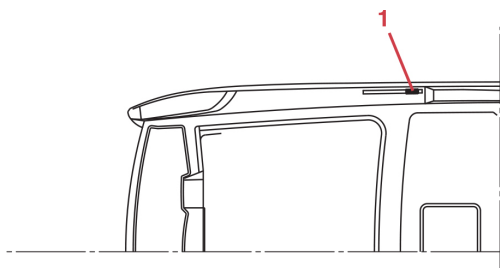

COB\_0456\_A

### 1—Port Side Lever

7. Move to the starboard side, lift up and hold the release lever and fold down the Bimini top.

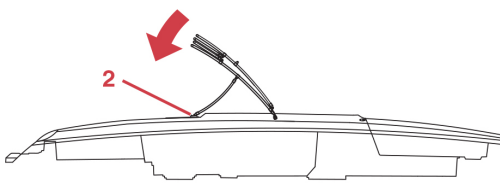

COB\_0458\_A

### 2—Release Lever

8. Once the top is folded down, secure the locking levers into the aft locking position.

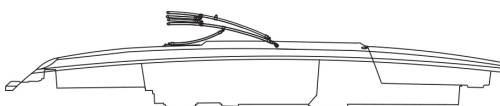

COB\_0457\_A

9. To deploy the Bimini top, reverse the above procedure.



## Arch With Bimini

(Before using this component, be sure to read all the **Danger, Warning** and **Caution** statements at the beginning of this section.)

### NOTICE

**Do not operate equipment that has loose or missing fasteners. Be sure all fasteners are installed and properly tightened before operating equipment.**

1. Fold the aft Bimini bow toward the back of the boat (aft).
2. Remove the canvas boot.
3. Unfold the canvas and deploy over the top of the arch and put the hole in the canvas over the anchor light on top.
4. Move forward the Bimini bow to top quick release position and attach the short Bimini poles to the forward bow and quick release.
5. Unzip the forward bow support pocket on the canvas, pull over the forward Bimini bow and rezip the canvas.

6. Pull the aft end of Bimini down tight, using adjustable poles to hold tight.



## Electric Arch with Bimini

(Before using this component, be sure to read all the **Danger, Warning** and **Caution** statements at the beginning of this section.)

### NOTICE

**Do not operate equipment that has loose or missing fasteners. Be sure all fasteners are installed and properly tightened before operating equipment.**

1. To raise and lower, turn on the master switch in the helm area, and raise and lower with the switch located in the aft walk-thru area.
2. Fold the aft Bimini bow toward the back of the boat.
3. Remove the canvas boot.
4. Unfold the canvas and deploy over the top of the arch and put the hole in the canvas over the anchor light on top.
5. Move the forward Bimini bow to top quick release position and attach the short Bimini poles to the forward bow and quick release.
6. Unzip the forward bow support pocket on the canvas and pull over the forward Bimini bow and rezip canvas.
7. Pull the aft end of Bimini down tight, using adjustable poles to hold tight.



## Stainless Steel/Aluminum Arch with Sunshade—Optional

(Before using this component, be sure to read all the **Danger, Warning** and **Caution** statements at the beginning of this section.)

### NOTICE

**Do not operate equipment that has loose or missing fasteners. Be sure all fasteners are installed and properly tightened before operating equipment.**

### Installation

1. Position the canvas on the top side of the sunshade tube frame. The long zipper located near the ski pylon will extend the length of the boat when installed. The three forward flaps will be positioned evenly between the framing of the sunshade.
2. Open the three forward flaps and wrap the flap around the forward tube.





3. Zip. (There is a small Velcro flap for securing the zipper pull.)
4. Ensure the long zipper on the aft end of the canvas is zipped closed.
5. Locate the flaps near the center of the underside of the canvas. These flaps will align with the tubing going side-to-side on the sunshade.
6. Wrap the flaps around the tube and secure the Velcro flaps.
7. Open the three aft flaps on the canvas and locate the two straps sewn to the inside of the center flap. Unbuckle the straps. The end, sewn to the flap, will drop down below the aft side of the tube.
8. Reattach to the end, which is sewn to the underside of the canvas. This will allow tension to be pulled on the canvas as the deployment is completed.
9. Pull the canvas tight from bow to stern by rotating the canvas around the aft tube and pulling on the two aft straps.
10. Secure the Velcro flaps.
11. After the canvas is snug bow to stern, open and secure the side flaps to the outer tube framing of the sunshade. Pull the canvas tight side-to-side by rotating the flap around the tubing and securing the Velcro flap.

### NOTICE

**The small straps/buckles located inside the aft corner flaps should be folded up and stored inside the flap when installed. These straps are for securing the sunshade in the folded position only. Any other use could cause equipment failure, which is not covered under warranty.**

#### Removal

1. Open all Velcro flaps.
2. Release the two aft buckle straps.
3. Unzip the flaps.



### Black/White Electric or Folding Arch with Sunshade—Optional

(Before using this component, be sure to read all the **Danger, Warning** and **Caution** statements at the beginning of this section.)

### NOTICE

**Do not operate equipment that has loose or missing fasteners. Be sure all fasteners are installed and properly tightened before operating equipment.**

### NOTICE

**Canvas should be stored in a protective covering to avoid damage to the canvas when not installed.**

### Installation

1. Remove canvas from protective covering. Unfold the canvas and identify the bow and stern areas of the canvas. The bow section will have three flaps with zippers.
2. Position the canvas on the top side of the sunshade tube frame. The long zipper located near the ski pylon extends the length of the boat when installed. The three forward flaps will be positioned evenly between the framing of the sunshade.
3. Open the three (3) forward flaps and wrap the flap around the forward tube.
4. Zip. There is a small Velcro flap for securing the zipper pull.
5. Ensure the long zipper on the aft end of the canvas is zipped closed.
6. Locate the flaps near the center of the underside of the canvas. These flaps align with the side-to-side tubing on the sunshade. Wrap the flaps around the tube and secure the Velcro flaps.
7. Open the three (3) aft flaps on the canvas and locate the two (2) straps sewn to the inside of the center flap.
8. Unbuckle the straps. The end, sewn to the flap, will drop down below the aft side of the tube.
9. Reattach to the end, which is sewn to the underside of the canvas. This will allow tension to be pulled on the canvas as the deployment is completed.
10. Pull the canvas tight from bow to stern by rotating the canvas around the aft tube and pulling on the two (2) aft straps.
11. Secure the Velcro flaps.
12. Once the canvas is snug bow to stern, open and secure the side flaps to the outer tube framing of the sunshade. Pull the canvas tight side-to-side by rotating the flap around the tubing and securing the Velcro flap.

### NOTICE

**The small straps/buckles located inside the aft corner flaps should be folded up and stored inside the flap when installed. These straps are for securing the sunshade in the folded position only. Any other use could cause equipment failure, which is not covered under warranty.**



### Bow Shade—Optional

(Before using this component, be sure to read all the **Danger, Warning** and **Caution** statements at the beginning of this section.)

### NOTICE

**Do not operate equipment that has loose or missing fasteners. Be sure all fasteners are installed and properly tightened before operating equipment.**



To install the bow shade, flip one the four (4) corner covers and insert the carbon fiber poles into the sockets.

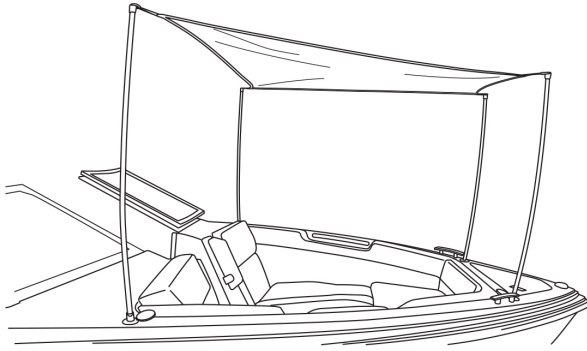

COB\_0566\_A

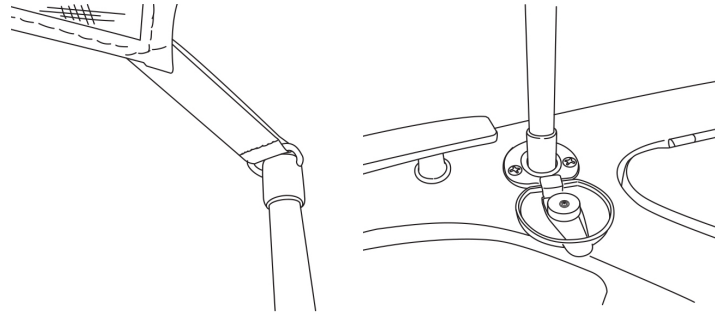

COB\_0567\_A

COB

**⚠ WARNING**

Orient the shade material with the small side toward the bow. Connect the webbing with the “D” ring at each corner to the top of the corresponding pole.

**DO NOT use the bow shade while underway. Air getting beneath the bow shade while the boat is moving, especially on plane, can upset the balance of the boat and could result in loss of control of the vessel.**





# OPERATING INFORMATION

This section is not intended to provide complete training on all aspects of boat operation. **Cobalt cannot anticipate and warn of every potential instance that could result in injury or death.** However, thorough training and education prepares boaters to more quickly and better anticipate and/or react to unusual or potentially dangerous situations.

We strongly recommend that all operators of this Cobalt boat seek additional training on boat handling and safety. Your authorized Cobalt dealer can assist boat owners and operators in the best resources for such training. Have all operators become familiar with the handling characteristics and proper steering and control system usage before attempting operation, and especially prior to high-speed operation.

## WARNING

**Improper operation can be extremely hazardous. Read and understand this manual, the propulsion unit operator's manual and any other accessory or components of your boat. Be sure that you understand all controls and operating instructions before attempting to operate the boat.**

Your safety, the safety of your passengers, and the safety of other boaters are among your responsibilities as operator of this boat. Follow the safety recommendations offered within this owner's manual, information on the U.S. Coast Guard's website regarding safety, and always follow common sense in operation and use of the boat. Your boat must be in compliance with USCG safety equipment regulations.

You should know how to react correctly to adverse weather conditions, have good navigation skills and follow the "rules of the road" as defined by the USCG and state, county and local regulations. Refer to the *Safety* section of this owner's manual for more information and details.

We cannot stress enough the importance of reading your propulsion unit operator's manual and following the manufacturer's instructions for breaking in your engine. Other information from component manufacturers may have been included in your new-boat owner's packet, and this information may also be critical to the safety and efficient operation of the boat.

During the break-in period, pay attention to any leaks. There will always be a small residue of water in the bilge, but other water leaks or fluid leaks related to the engine or fuel tank may appear. These leaks can be serious and should be addressed by an authorized Cobalt dealer.

# PRECAUTIONS

## Before You Start

- Become familiar with the location and operation of all equipment.
- Review the prelaunch requirements as outlined by the trailer manufacturer, and the preparations as required by the engine/drive-train manufacturer.
- Be sure that all onboard fire extinguishing equipment is fully charged and easily accessible.
- Have emergency plans in place.
- Be sure that a float plan or outing information has been left with someone ashore. This means that if any issues arise, there is a person to raise an alarm if you do not return as planned. (Cell phones are helpful, but sometimes service is not available, so bringing a cell phone on an outing should not be the only plan.)
- Ensure all safety requirements as outlined in the *Safety* section of this manual have been met.
- Be certain that the total number of people and gear onboard does not exceed the maximum allowed as indicated on the capacity plate.
- Be sure all gear is properly stowed. Gear that is left loose on the deck can become dislodged, move about during operation and could potentially go overboard or strike an individual onboard, resulting in potential

injury. See also *Loading* in this section.

- Check that the steering system is working properly.
- Be certain the battery is full charged and ready for operation.

## DANGER

**If it becomes necessary to re-charge a battery from an external source, DO NOT attempt to charge using automotive battery cables or use another boat battery as the source for charging. Some amounts of hydrogen gas are emitted during the charging process. This can be very dangerous. It is critical to keep all sparks, including smoking cigarettes, lighters or any type of flame, well away from a charging battery. Battery chargers for use in marine environments are available.**

## CAUTION

**Inside the battery is an electrolyte fluid that allows the chemical reaction to provide power. The fluid is comprised of several components, one of which is sulfuric acid. As with most acids, this is caustic and corrosive. If it comes in contact with skin, immediately flush the area with copious amounts of fresh, clean water. Follow up with medical assistance.**



- Double-check that sufficient fuel is in the fuel tank for the outing or have a plan for refueling.
- Check the weather forecast. Check the predicted wind and water conditions.
- Reconsider any outing that appears threatened by bad weather conditions.
- Check that the drain plugs are fully and correctly installed.
- Ensure that PFDs and other safety gear are onboard.
- Verify the shift level is in the *NEUTRAL* position.



## Fire/Explosion

Because fires can occur and spread very quickly, keep PFDs readily accessible at all times. Many fires result in abandoning ship.

Most fires are the result of fuel and oil accumulating in the bilge from careless fueling practices.

**When boating in the United States, boats of less than 26 feet in length are required to have at least one B1-rated, hand-held fire extinguisher onboard and fully charged, unless there is an automatic fire extinguishing system installed. If the boat does not have an automatic fire extinguishing system installed, the boat owner MUST purchase and install at least one B1-rated fire extinguisher. Most other countries also have some type of fire extinguishing and suppression requirements for recreational boats.**

**It is the responsibility of the boat owner and/or operator to determine the requirements for the body of water on which the boating will occur. To avoid citations and/or arrest, boaters should check with local governmental agencies regarding specific requirements and limitations for boating.**



**Whenever fire extinguishers or suppression units have**

**been used in fighting an onboard fire, a careful determination should be made whether it is safe to operate the boat. In most instances, it is advisable to have the boat towed to shore rather than risk additional fire or permanent damage to the drivetrain. The boat should be thoroughly serviced by an authorized Cobalt dealer prior to operation again. Operation prior to service could result in additional damage to the boat and may result in serious injury or death.**

Even if systems are not discharged, fire extinguishers and suppression units require periodic maintenance. Hand-held units should be examined regularly for rust, corrosion, damage, or leakage. Weigh the unit annually to be certain that it meets the minimum listed on the label. If it has been used at any time, even partially, it should be recharged by a qualified fire-extinguisher servicing company.

When purchasing fire extinguishing and suppression units, Cobalt strongly recommends buying units that are prepared specifically for the marine environment. The standards for these units have been established by the U.S. Coast Guard and the American Boat and Yacht Council (ABYC). In other countries, follow the recommendations and requirements of local jurisdictions and boating authorities.

**Cobalt recommends fire extinguishing and suppression systems that exceed the minimum requirements.**

In the event of a fire, use the fire extinguisher at the base of the flames, using a sweeping motion. Prudent and accurate use of the available chemicals should contain all but the worst fires.

Verify that the fire has been extinguished. If so, check the damage and get assistance immediately. If the fire cannot be extinguished, get out and swim at least 25 yards (23 meters) upwind from the boat and use the visual distress signals to get assistance.

Refer to the *Safety* section earlier in this owner's manual for additional information.

# LAUNCHING

Federal and local laws require certain safety equipment to be onboard at all times. In addition, responsible boaters carry other equipment in case of an emergency. Check with local boating authorities for any additional requirements over and above federal requirements.



## Boarding

When boarding the boat, always step in. Do not jump. Avoid stepping on fiberglass or other potentially slippery surfaces. Board one person at a time.

- Do not board the boat while carrying gear. Set the gear on the dock, board the boat and then pick up the gear.



## Loading

**Do not overload your boat.** The performance of your boat is dependent on load weight and distribution. Passengers should distribute themselves to maintain trim. Remember to distribute weight from right to left, and also from front to back.

- Avoid excess weight in the bow or stern.
- Securely stow all extra gear in stowage areas to prevent load shifting. Do not stow gear on top of safety equipment; safety equipment must be quickly accessible.
- In adverse weather, reduce the load in the boat. People/load

capacity ratings are based upon normal boating conditions.

- Do not use the drive unit as a boarding ramp; use the boarding ladder. To prevent injury, make sure the engine is off when swimmers, divers and skiers are boarding. Overloading of passengers, personal equipment and supplies could result in an accident, especially in rough waters. Store all gear in secure areas. Maintain a balanced load at all times.



## On the Water

Start your engine before casting off. Remember, the boat turns from the stern. Allow plenty of space between the boat and the dock before trying to move away.



**All passengers should be carefully seated while the boat is moving. DO NOT sit on the bow, bow pulpit, deck, gunwale or sundeck pads when the boat is moving.**



**DO NOT overload the boat. Overloading or uneven loading can cause loss of control, capsizing or swamping, which may lead to death or serious injury. Adhere to the load capacity plate restrictions and always account for persons, gear and all non-factory-installed ballast or other equipment.**

# GETTING UNDERWAY

There are many things to consider when planning a safe and enjoyable boating trip.

You are responsible for the safety of all passengers, the boat and any damage the boat or its wake may cause. **Keep passengers from blocking your view so that you do not run into other boats, swimmers, water skiers, personal water vehicles or aids to navigation.**



## Propulsion System



**Always check bilge and engine compartment for fuel fumes before starting the engine. If there is an odor of fuel, do not start the engine until the problem has been fixed and fumes have been eliminated. Always keep hands, feet, hair and clothing away from water intake and drive unit. Do not attempt to clear debris or perform**

**other maintenance while the engine is running. Always remove the clip from the emergency safety stop switch to prevent accidentally starting the engine while working on the propulsion system.**



**Do not exceed the posted engine rating of your boat. Boat power capacity has been rated for maximum performance and safety. Exceeding power capacity is illegal in many areas. Never use a propeller that allows the engine to exceed recommended RPM under normal wide-open throttle operation.**

*Pre-Operation:*

- Test operation of the carbon monoxide detectors.
- Open all seacocks and check for leaks.
- Check seawater strainers for leaks and accumulation of debris.
- Open windows, doors and hatches.
- Check that no fuel, oil or water is leaking or has leaked



into the bilge compartment.

- Check all hoses and connections for leaks and damage.



**DO NOT operate the boat if any problem is found during this inspection. A problem could lead to an accident when using an unsafe boat. Immediately have any issues addressed and corrected by your authorized Cobalt dealer.**

- Operate bilge blowers for at least four (4) minutes before starting engines or generators.

*During Operation:*

- Check gauges frequently for signs of abnormal operation.
- Check that steering, shift and throttle controls continue to operate smoothly.
- Check for excessive vibration.
- Monitor your fuel supply.
- Verify batteries are charged.

*After Boating:*

- Where equipped, to prevent marine growth from accumulating on the hydraulic cylinder shafts, make sure trim tabs are up and propulsion unit drives are in the full trim **DOWN** position.
- Remove the ignition keys.
- Close all water inlet seacocks.
- If possible, inspect the hull and propellers for damage.
- Clean any spills, stains or moisture from the boat. Inspect sea strainers.

- Remove any food, garbage and wet gear from the boat.
- Secure lockers, hatches and canvas, as equipped.
- Verify that bilge pumps operate properly, and pump the bilges dry by way of the manual switch.
- Clean the bilge and check for fuel, oil and water leaks.
- Stow PFDs and other safety gear and equipment dry.
- Fill fuel tanks (allowing for expansion) to prevent condensation.
- Turn battery select switches off.
- Turn off the DC breaker on the electrical panel. If not using shore power, turn off the AC breaker.
- Notify the person with whom you filed a float plan of your return.
- If the boat is removed from the water, wash the hull and deck exterior with fresh water.



### Handling Dock and Mooring Lines

Be sure to use enough fenders to protect your boat from damage. Use only good quality, double-braided nylon line. Protect your boat's finish by using chafing protectors on the lines. Use only the cleats, bow eye and stern eyes to secure your boat. Do not use the handrails or the windshield. The foredeck handrails should be used only for tying a "Jackline" in an emergency situation. If possible, tie up your boat with the bow toward the waves and leave a little slack in the lines to allow for some wave movement or tidal action.



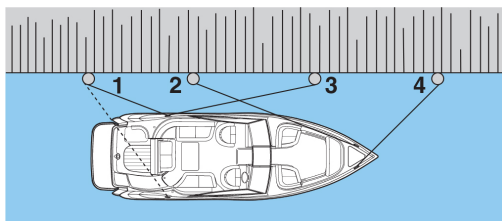

COB\_0060\_A

- 1 – Stern Line
- 2 – Forward Quarter Spring
- 3 – Aft Bow Spring
- 4 – Bow Line

Use your dock lines to help maneuver the boat near the pier and to secure it. Use the following information to secure your boat to a pile or dock cleat:

The bow line is fastened to the bow cleat and is pulled forward at about a 45° angle. This line keeps the boat from moving astern.

The stern line is fastened to an aft cleat and pulled astern to about a 45° angle. This line keeps the boat from moving forward.

The spring lines can help you control the boat when leaving a dock. Be sure to use spring lines when boating in waters where the tide movement is significant. The forward quarter spring line is fastened to a forward cleat and heads aft. The aft bow spring is fastened to a stern cleat and heads forward.



**WARNING**

**Never insert a hand, arm or other body part between the dock and the boat or attempt to keep the boat from hitting the dock. The boat could push against the dock, pinning the appendage, and causing severe injury.**

Additional docking information is included in this owner's manual.



# Care and Maintenance



# INTERIOR/EXTERIOR CARE AND MAINTENANCE

The best way to take care of your Cobalt boat is with prevention and proper care. Not all of the care methods within this section may apply to your boat.

## ON-GOING CARE

### General Cleaning

Cobalt recommends always keeping the boat clean. Immediately after an outing, the boat's exterior and interior should get a thorough rinsing with clear, fresh water, and then should be allowed to air dry prior to covering with canvas. If this is not possible, the boat's cover should be removed as soon as you arrive at your destination and allowed to dry.

#### NOTICE

**Boats must be thoroughly rinsed inside and out with clear, fresh water following all outings and then allowed to completely dry prior to storage or parking. Failure to do so could result in damage to the finishes and the development of mold or mildew, or permanent stains. Such damage is not covered under warranty.**

#### NOTICE

**Consumers should never add aftermarket waterproofing to canvas. The canvas must "breathe" to avoid mold and mildew. If any spray-on waterproofing has been added after delivery, it will void the warranty.**

If the boat will be left in water, the exposed areas should be wiped down with clear, fresh water and allowed to dry before boat covers are installed.

### Salt Water Care and Maintenance

When boating in brackish or salt water, the post-outing cleaning is critical for the protection of the finishes. The cleaning process, internally and externally, is critical to maintaining the warranty in effect and to preserving the engine components. **This is a safety matter.**

The potential for corrosion means that boats operating in this type of condition must be equipped with self-sacrificing zinc anodes. These anodes are attached in several locations. Check with your authorized Cobalt dealer to be certain that you are aware of all locations of the anodes as they will require periodic replacement. The anodes serve to significantly reduce the potential for corrosive damage to the permanent metal components on the boat.

#### NOTICE

**Failure to follow ANY of the Saltwater Care and Maintenance instructions for care and maintenance will void the warranty. Significant damage occurs to the engine and boat if proper maintenance is not followed as outlined in the manuals.**

### Stainless Steel, Chrome and Aluminum Components

While Cobalt uses quality metal components chosen for their durability as well as attractive appearance, all metal eventually reacts to water exposure. Therefore, part of the care and maintenance of metal requires that it is kept clean and dry.

Stainless steel, though highly resistant, is still capable of rusting, particularly in the marine environment. Initial signs of rust and corrosion, left untreated, may result in pitting and permanent damage to components. After an outing, rinse the metal pieces as well as the rest of the boat, allowing a thorough air drying. To avoid spotting and discoloring, drying with a soft rag or towel will keep the new boat look for many seasons to come.

Waxing these metal components helps to preserve the finish. **Do not wax powder-coated surfaces as the wax will collect in the textured surface and be extremely hard to remove.**

Keep your stainless steel looking new by cleaning monthly with a good quality stainless steel cleaner or polish. Always clean and polish in the direction of the grain and finish.

If the boat owner notices rust or deterioration of metal components below the waterline, even when the boat is operated regularly in fresh water, this should be brought to the attention of the authorized Cobalt dealer. In some instances, it is necessary to attach self-sacrificing zinc anodes, even when boating in fresh water.

#### NOTICE

**Damage that occurs to the boat because of corrosion is not covered under warranty.**

The following steps will help protect against such occurrences:

### Preventive Steps

Clean and wax metal brightwork prior to extended storage. In saltwater or other harsh environments, repeat more often as needed. High-quality stainless steel cleaners and conditioners are commercially available. Rinse with fresh water and wipe dry with a towel or chamois cloth after each use.

### Cleaning Stainless Steel

Remove rust or corrosion promptly using a good metal cleaner/polish. Delay may contribute to permanent damage to finishes. Do not use steel wool or other coarse abrasives, or clean with acids or bleach. **DO NOT** use cleaners that are not for use on stainless steel, such as glass, tile or counter cleaners, or citrus-based cleaners. These types of cleaners can damage the surface per-

manently. Apply metal or automotive wax after cleaning for additional protection. Always test a product in an inconspicuous area before applying to the complete surface.

If hardware or fasteners require replacement, be certain that replacements are rated for the marine environment. See your authorized Cobalt dealer for further information and assistance.

### DANGER

**Some solvents are highly flammable and toxic. Exercise proper care in cleaning, wear protective gear and provide adequate ventilation. DO NOT store soiled cleaning cloths onboard; store or dispose of used cleaning cloths properly ashore.**

### CAUTION

**Use caution in cleaning around stitching, wood or other decorative trim, as well as vinyl and flooring, as solvents could permanently damage these materials.**

## CORROSION PROTECTION



### CorrosionX

Regular applications of CorrosionX can protect components that are subject to damage caused by corrosion, a naturally occurring result of operating in marine environments, particularly salt water. A sample can of CorrosionX has been included with the optional salt water kit.

At a minimum, a light coat of CorrosionX should be applied to the following areas and components in the time frames specified (and remove any excess):

#### Every Month:

- Hydraulic cylinder shafts for steering and other operating mechanisms

#### Every Two Months (Salt Water):

- Rails
- Stanchions
- Cleats
- Cleat bolts
- All metal fixtures/fittings on deck
- Hinges/locks/closure mechanisms on doors and windows
- Sliding tracks on doors and windows

#### Every Two-to-Three Months:

- Light sockets

#### Every Three Months:

- Bilge pump housing and connections
- Other metal within the bilge area
- Thru-hull fittings
- Seacock fittings

#### Every Four Months (Brackish and Fresh Water):

- Rails
- Stanchions
- Cleats
- Cleat bolts
- All metal fixtures/fittings on deck
- Hinges/locks/closure mechanisms on doors and windows
- Sliding tracks on doors and windows

#### Every Six Months:

- Plumbing connections in the galley and head areas
- Entire engine, including engine mounts, unless otherwise directed by the engine manufacturer
- Fuel line fittings at the fuel tank

#### Once a Year (All Water Environment):

- Electrical connections
- Fuse panels
- Antenna bases
- Hinges/locks/sliding tracks of doors and windows



**A good rule of thumb: If a component can rust or corrode, whether it has or not, it requires application.**

For any questions about CorrosionX, check the manufacturer's website:

<http://www.corrosionx.com>

or call 800-638-7361.

**Avoid getting CorrosionX on other, non-metal surfaces, particularly vinyl seats or flooring. If this occurs, clean immediately as directed by the product's directions to avoid stains that are also not covered under warranty.**

#### NOTICE

**Failure to use CorrosionX as directed on the product label will result in the nullification of the Cobalt warranty in instances of corrosion damage. Failure to clean CorrosionX off non-metal surfaces can result in damage that is not covered under warranty.**

#### NOTICE

**Cobalt uses only marine-rated and marine-grade fasteners on all models. If, at any time, it is necessary to replace any fasteners, seek guidance from an authorized Cobalt dealer to ensure that such replacements meet the requirements for operation in a marine environment.**



### Galvanic Corrosion and Zinc Anodes

Galvanic corrosion can result in serious damage to any metal component of your Cobalt boat. Galvanic corrosion is the deterioration of metals due to the effects of electrolytic action. When dissimilar metals are immersed

in a conductive fluid such as salt water, an electric current is produced, similar to the action inside a battery.

Galvanic corrosion can occur in fresh water or salt water; however, salt, brackish and polluted waters accelerate galvanic corrosion.

When a self-sacrificing anode is installed on your Cobalt boat, it works to help prevent damage to metal components from galvanic corrosion. The anode is attached to the exterior of the boat, on the transom below the waterline. Other metal components are attached to the transom zinc anode via grounding wire. *(There may be additional anodes affixed; check with your Cobalt dealer for details.)*

The anode will require frequent inspections. If the anode shows deterioration of 50% or more, it must be replaced for continued protection. Please note that because this is a natural function of operating in certain bodies of water, the cost of replacement is not covered under warranty.

#### NOTICE

**The sacrificial zinc anodes do not totally eliminate the corrosion process from the rest of the boat and its components. It is critical for the boat to be rinsed and flushed after EACH use. Failure to do so will void the warranty.**

#### NOTICE

**DO NOT paint an anode, its fasteners or its mounting surface. Painting will reduce the anode's corrosion protection capabilities. Make sure the anode's contact to its mounting surface is clean and secure.**

Refer to the propulsion unit operator's manual and speak with your Cobalt dealer for requirements or galvanic corrosion protection for the unit.

## VINYL INTERIOR AND UPHOLSTERY

**(The following overview contains information that is applicable to canvas and other material used in production for comfort and protective elements of the boat.)**

#### NOTICE

**The performance results shown in this information are not guaranteed for all upholstery products. The evaluations are indicators after laboratory tests and may not be indicative of field performance.**



### Mold & Mildew Cause and Prevention

Mold and mildew spores are ever present in air and soil, and most will germinate when exposed to temperatures above 75° F and relative humidity of 50%, with

rapid spread occurring at 80%; however, some can grow in significantly lower temperatures and RH levels.

All fabrics will support growth but some synthetics are treated with an anti-microbial agent which adds to their growth resistance. Anti-microbial treatments protect the base surface itself, so that alone won't support spore growth. However, organic soiling on top of those surfaces will. Once a population is established on the cover, vinyl seating or gel coat, an irregular stain will appear which ranges in color from gray to black; however, yellow, orange, and red stains are possible. Sometimes UV exposure can fade them but most often they remain permanent stains.





## Treatment

*(This is very time-consuming, with limited expectations of success. Therefore, it is desirable to avoid the necessity of mold and mildew treatment.)*

- If growth is established, vacuuming with a HEPA filter unit would be the first step followed by cleaning.
- For fabric and vinyl surfaces, shampoo lightly with an upholstery shampoo.



## Focus on Prevention

The key in eliminating mold growth is controlling moisture. Remove it as a factor and growth simply will not occur, so maintaining a cool and dry condition with clean surfaces is paramount. Using a dehumidifier isn't practical for boat storage, but a simple remedy can be using desiccant bags. They must be monitored as they will absorb moisture and become ineffective, but they can be replaced, and this is a relatively inexpensive method. They are available in packs for a normal-sized boat and called Boat Dry, purchasable from Sun Solutions at [ww.sunsolutionproducts.com](http://ww.sunsolutionproducts.com).

*When the boat is ready to store, the best practices are:*

- Clean and dry the boat thoroughly.
- Place a Boat Dry set of desiccant bags throughout the boat.
- Put the mooring cover on and tightly ratchet (seal will be created at the rub rail).

Drying out a boat is difficult but the extra care you take will keep your boat looking new for a long time.



## Condensation Cause and Protection

Water vapor in the atmosphere will condense onto another surface only when that surface is cooler than the dew point temperature, or when the water vapor equilibrium in the air has been exceeded. The dew point temperature is based on the air temperature and relative humidity. A typical example is with 90°F air temperature and 50% RH, the dew point temperature is about 73°F.

Many times during the evening, dew will condense onto all outdoor surfaces like grass, cars, patio furniture, toys, bikes, and the like as the air temperature and surfaces cool below the "dew point." Once the morning sun heats the air temperature or those surfaces heat up enough, the dew will evaporate back into "humidity" and this cycle continues as long as the weather conditions permit.

When you cover your boat, you are sealing the outside air in its present state under the cover. Also, if the boat wasn't dried out, that additional moisture will add to the wetness of the trapped environment. As the air and surface temperatures cool below the dew point the water vapor in that air will condense onto all surfaces inside the boat. In the morning, it will take longer to heat the air and surfaces under the cover as it affords protection, thereby lengthening the time it takes to have the condensation evaporate. It's very possible if weather conditions change that the condensation may not return to vapor for quite some time.

This condition is often misunderstood as the cover "leaking" water through the fabric, but because of the fabric's high hydrostatic water resistance (160 cm) this is not possible. It's understandable to think that having



the cover wet underneath is somehow due to it allowing water through, but it is just condensation forming on its surface. It's like camping in a synthetic tent; if you've ever done it, you'll remember water beads form on the tent surface, and bumping the tent would cause them to "rain" on you.



## Pooling Water

Water can pool inside the deck or on a canvas cover for various reasons. If pooling is noticed, the standing water should be drained or otherwise removed as soon as possible. Pooling water accelerates the process of mold/mildew development, as well as other serious staining and potentially permanent damage.



## Current Reality

To have a mildew problem, four elements are required. For mildew to proliferate, spores, food, warmth, and moisture are necessary. Elimination of one of these elements would break the cycle, and the mildew problem would be eliminated.

The most likely element to control is moisture. Keep surfaces dry and the ambient air dry, and you can break the link. This is very difficult. Marine upholstery may be dry when one sits on it, but it is constantly exposed to rain, splashes, and wet bathing suits.

Dirt carried by the wind or a sudden shower will carry the spores or seeds to begin the process, inoculating the surface. Surface debris can easily be washed off, but what happens to the contamination that gets into a seam or stitch holes?

A closer examination reveals that a marine seat is a very complex construction. The vinyl that you look at or sit on is only a part of the total construction. The vinyl is usually attached to a fabric to give it dimensional stability and physical strength. Urethane foam of various thicknesses provides a cushion, and the whole seat is usually built on a piece of plastic.

If contaminated dirt carried by rainwater gets inside the cushion, the biological growth cycle can begin. It is quite common for soil organisms growing in the foam cushion to produce colored by-products, the most notable of which is a pink compound.

This dye is soluble in plasticizer (an ingredient in flexible PVC) and will diffuse and migrate to the vinyl surface. Even though the vinyl compound is adequately protected against mildew growth, pink staining can occur if contact is made with components of a seat which support mildew growth. This stain cannot be removed by washing.



## The Solutions

As in most complex problems, there are a variety of actions one can take to prevent microbial problems. These actions must be directed to the components of the product and the total construction. Working together, they will assure the highest probability of success in eliminating quality problems associated with mildew contamination. The solution consists of four components:

- Keep seats clean.
- Remove or kill any surface growth.
- Use materials that are treated to inhibit fungal growth.
- Keep surfaces covered, if possible, when not in use.

### NOTICE

**The vinyl used in Cobalt boats contains the biocidal product n-octyl isothiazolinone (OIT), an antifungal additive used to help maintain appearance, physical properties and prolong the service life of the vinyl.**



## Additional Information

The vinyl and interior fabric in your Cobalt boat has been specially selected to hold up under the elements and usage of an active boater. Even quality material is vulnerable to abuse, however. Cobalt upholstery requires reasonable care and treatment, and to that end users should also avoid sharp objects that may cut or tear your vinyl.



## Care and Cleaning of Vinyl

Most common everyday light soiling can be easily removed by using a solution of 10% liquid household dish soap and 90% warm water, applied with a clean, dampened cloth. Rinse with a clean cloth dampened with water and allow to dry. Moderate scrubbing with a soft-bristle brush will help loosen dirt and grime embedded in the grain of the vinyl.

See specific cleaning instructions provided by the manufacturer and located in your boat packet.

### NOTICE

**It is extremely important to clean the stained area as quickly as possible, making sure the recommended cleaning steps are followed in order.**



**Avoid open flame or spark. Some cleaning fluids contain flammable liquids, which are extremely dangerous and must be used in well-ventilated areas.**





## Spot and Stain Removal

Even with routine maintenance, stains and spots will occur. Clean up spills as quickly as possible. Watery spills should be blotted with clean cloths or paper towels. Thick jelly-like substances should be removed with a spoon or blunt scraper, and then blotted. Solids should be scraped using a blunt scraper and then swept, brushed or vacuumed to remove the material. After removal of the majority of the spilled material, it is important to complete the removal process so the spill does not have a chance to affect the flooring.

Whittaker manufactures a spotting and brushing system using Crystal Dry Spotter and Cleaning Agent and

the Whitaker Carpet Roamer™; it is effective in cleaning the stains listed below where brushing is required.

Plynyl is stain-resistant, not stainproof. To avoid lasting stains, blot and clean stains immediately. The following list shows stain-removal procedures for some common spills and other tough-to-clean areas.

### NOTICE

**The material and vinyl used in Cobalt interiors has been treated to be stain-resistant. It is not stainproof. Remove staining agents as soon as possible to improve the odds of avoiding permanent stains.**

### Removal Suggestions

#### Stain

#### Removal Procedure

*Shoe heel marks*

Use medium-bristled scrub brush and follow with mild detergent solution.

*Blood, chocolate, catsup, white glue, egg, ice cream, butter*

Spray on a mild detergent solution and allow it to dwell for 1 minute. Brush with a medium-bristled scrub brush, and then blot with paper towels. Repeat until discoloration is removed.

*Berries, fruit juices, cream, soft drinks, milk, wine, beer, coffee, tea*

Spray on a mild detergent solution and allow to dwell for 1 minute. Blot with white paper towels. Repeat until discoloration is removed.

*Excrement, vomit, urine*

Spray on a mild detergent solution and allow it to dwell for 1 minute. Brush with a medium-bristled scrub brush, and then blot with white paper towels. Repeat until discoloration is removed.

*Shoe polish, asphalt, grease, oil, ink, lipstick, crayon, wax, paint, rubber cement, seam sealer*

Remove as much residue as possible using white towels, paying attention to keeping the stain from spreading. Use a mild solvent (Bane Clene Saf-T-Solv®) placed on white towels and then applied to the stained area. Repeat the application of the solvent and gently agitate the area as much as needed. Overapplication of any solvent can dramatically affect the integrity of Plynyl. Follow solvent cleaning with a detergent rinse.

*Mercurochrome, Merthiolate, Betadine, tomato sauce, spaghetti sauce*

Spray on a mild detergent solution and allow it to dwell 1 minute. Blot with white paper towels. If discoloration is not removed, dilute household bleach to 1:10 bleach-to-water, mist on affected area and allow it to dwell for 5 minutes. Rinse thoroughly with water to remove all bleach residue.

*Chewing gum*

Freeze with compressed air and break away from material surface. Follow mild detergent and a medium-bristled brush.

*Rust*

Treat with a reducing agent and follow with a mild detergent rinse (may require professional assistance).



**Follow all cleaning procedures using common detergents with a water-only rinse in order to removal all residual cleaning agents (if Crystal Dry is used, a follow-up water rinse is not required). Allow the area to completely dry before allowing traffic in the area. **NO-TICE: Stains that cannot be removed under the listed procedures can be treated with a 1:10 bleach-to-water solution. Mist the solution on the area of discoloration and allow it to dwell for five (5) minutes. Rinse the area with water only in order to remove the bleach residue. Allow to dry completely before trafficking. Some stains may require a professional to complete the stain-removal process.****



## Leather Care

For spots and spills, wipe up excess liquid immediately with a clean absorbent cloth or sponge. If necessary, use clean lukewarm water only and let air dry naturally. If water is used, clean the entire area where the spot occurred. For example, clean the entire seat cushion or entire arm.

Do not dry wet areas with hair dryers.

For stubborn spots and stains, use a mild non-detergent cleaner such as a bar of Ivory Soap™ or Amway™ L.O.C. Apply the soap to a clean, wet sponge, wash, and then rinse well. Allow to air dry naturally.

For butter, oil or grease, wipe any excess off the leather with a clean dry cloth, then leave it alone; the spot should dissipate into the leather in a short period of time. Do not apply water or try to wash butter, oil or grease spot.

### NOTICE

**DO NOT use saddle soap, cleaning solvents, furniture polish, oils, varnish, abrasive cleaners, soaps or ammonia water.**



## Vinyl: Dark Storage Areas

Often, when a boat is stored completely covered or in a dark building, the vinyl will darken or become “dingy” looking. If this happens, simply place the boat in direct sunlight for a few hours and the vinyl will brighten up.



## Canvas



**Under no circumstance are these fabrics to be put in hot water, run through the hot drying cycle of an automatic dryer or steam pressed at a dry cleaner. Fabric should be air-dried.**

The optional bow and/or cockpit tonneau covers, Bimini top or Bimini enclosure on your Cobalt boat are manufactured from top-quality materials to provide you with years of trouble-free service when properly maintained.

The following information is provided to help maintain the appearance and ease of operation.

Cobalt uses Sunbrella®, a woven fabric made of 100% solution-dyed acrylic fiber. It is very colorfast and will withstand long-term exposure to the sun (ultra-violet) without excessive fading or deterioration.

- Do not store canvas wet or in an unventilated, moist area.
- Always roll the canvas instead of folding.
- Roll the top carefully around the bows and cover with the storage boot provided.
- Your canvas is designed and intended for short-term use only. Do not use it for storage.
- Do not tow your boat with the top in the upright position.

## Cleaning Canvas

Canvas should be cleaned regularly before substances such as dirt particles are allowed to accumulate on and become embedded in the fabric. The fabric can be cleaned without being removed from the installation. Simply brush off any debris, hose down and clean with a mild solution of natural soap in lukewarm water (no more than 100°F). Rinse thoroughly to remove soap. **DO NOT USE DETERGENTS.** Allow to air dry. Do not store canvas wet or in an unventilated, moist area as it will result in mold or mildew penetration, which is difficult to remove.

## Special Cleaning Problems

For heavily soiled fabric, remove the top from the frame. Soak the fabric for approximately 20 minutes in a solution that has been mixed to the following proportions:

- ½ cup (4 ounces) of non-chlorine bleach
- ¼ cup of mild soap like Ivory Snow, Dreft™, or Woolite™
- One gallon of lukewarm water (water should be no more than 100°F (37.8°C))

Allow the fabric to soak until the non-chlorine bleach has killed the mildew or other microbes and the stains can be brushed out with a soft scrub brush. Rinse the fabric thoroughly in cold water to remove all of the solution.

This may require rinsing several times. **Incomplete rinsing can also cause deterioration of sewing threads and prohibit the fabric from being properly retreated.** Do not soak excessively, since the non-chlorine bleach can deteriorate the sewing threads. Allow the fabric to air dry completely.

Sunbrella may also be dry cleaned. **DO NOT STEAM PRESS OR DRY IN AN ELECTRIC OR GAS DRYER.** Sunbrella is thermoplastic, or heat sensitive. Excessive heat can damage and shrink the fabric.

These methods of cleaning may remove part of the

water and stain repellency that was applied to the fabric during its manufacture. The fabric should receive an application of an air-curing treatment such as “303 HIGH TECH FABRIC GUARD” after it has been cleaned.

### NOTICE

**Failure to follow canvas care and maintenance instructions as explained in this section of the owner’s manual can result in deterioration of the product, which is not covered under warranty.**



## Other Canvas Components

### Clear Vinyl “Isinglass”

The clear vinyl “isinglass” used in side curtains, aft curtains and visors is very reactive to heat and cold. Carefully unroll the vinyl in cold weather to avoid cracking. Keep vinyl side curtains from touching the bows (tubing) to prevent burning the vinyl. If the boat is stored with top, side curtains and aft curtain in place, heat buildup inside of the boat may discolor the vinyl.

Use a soft, clean cloth with a solution of Ivory or Lux soap, liquid or flakes, and lukewarm water. Never use any harsh or abrasive cleanser; these types of cleaners will scratch the glass. To keep the vinyl soft and flexible, regularly apply a UV screening agent such as “303 PROTECTANT.”

- Do not fold or wrinkle curtains; roll smoothly when storing.
- **NEVER** store the isinglass wet or in an unventilated, moist area.
- Always roll the glass instead of folding.
- Handle the isinglass carefully. It is soft and very prone to scratching.

### Zippers

When zippers are new, they can be more difficult to zip than when “used.” Zip carefully without forcing. They will loosen with use. Keep the zippers clean. A zipper lubricant may be used to help new zippers and to maintain long service. The most vulnerable part of the zipper is the base. Use care when starting a zipper to prevent damage.

### Snap Fasteners

Fasteners should be unsnapped as close to the button as possible. Never remove canvas by pulling roughly on one edge of the material. This can damage the canvas and the fasteners. To prevent snaps from becoming difficult to unsnap, keep them clean and use lubricants such as a small amount of Vaseline®, Chapstick®, WD-40®, silicone spray, etc. The most common recommendation is to rub candle wax or paraffin around the stud or inside the socket.

Whichever method is used, clean up any excess



application so the lubricant does not stain the canvas or any other surfaces it may contact.



## Storage Compartments

### NOTICE

**Storage compartments, including the glove box, should be kept clean. Failure to do so may result in damage or permanent discoloring and/or odors that are also not covered under warranty.**

Storage compartments, including the glovebox, should be cleaned out in accordance with the Care and Maintenance instructions in this owner’s manual. At least annually, all compartments require a thorough cleaning. If anything with residual odor is placed in a storage compartment, or if anything has spilled in the compartment, cleaning should occur as quickly as possible afterwards.

Do not store any aerosol items in the glove box. These can overheat and leak, and/or rupture. Any liquid or semi-liquid material placed in the glove box may spill or overheat. Care should always be used when placing liquids such as suntan lotion in the glove box. Cobalt is not responsible for such misjudgments.

If any water intrudes into a storage compartment or the glove box, clean it out as soon as practical. Mold and mildew can result if even small amounts of water are not removed. As with any storage location, any spills should be cleaned efficiently to avoid damage and/or odors.



## Cabinetry and Wood

### Cabinetry

Clean with any water-rinseable non-abrasive cleaner.

### Wood Grain Dash

Your Cobalt boat may be equipped with a wood grain dash, which will maintain its natural beauty and high-



gloss sheen when properly maintained.

- For routine cleaning, wipe the surface with a damp, soft cotton cloth. For thorough cleaning, wash the surface with a mild solution of soap and water, and dry with a soft cotton cloth.
- Do not use cleaners or polishes containing alcohol, ammonia, abrasives, oily emollients or petroleum-based materials.
- Avoid saturating the surface with polish or wax. In some instances, foam-backed tape used in manufacturing will absorb and retain these substances and result in premature fading and/or discoloration of your wood grain dash. If cleaners or waxes come in contact with edges, clean the surface immediately with a mild solution of soap and water.

### Cedar

Wipe the surface with a dry cloth or a slightly damp cloth. Do not seal or paint cedar.



## Sea Grass Floor Covering Cleaning Instructions

### General Maintenance Instructions

Plynyl® is made with a woven vinyl fabric bonded to commercial-grade backings. Vinyl is a very tough, durable material and few household or common office chemicals affect it. Routine maintenance along with periodic cleanings and diligent attention to stain-causing spills will provide a long, useful life.

The frequency of routine maintenance depends on the application. The frequency has to be determined by the user or through consultation with the manufacturer. The methods for routine maintenance as well as cleaning methods also depend on the application. Frequency depends on the amount of soil and dirt Plynyl is exposed to. Dirt and soil will degrade any flooring, so proper maintenance will increase its natural life cycle.

Plynyl is unique among soft floor coverings because water can be used effectively in daily maintenance. Detergents and shampoos with a pH up to 11 can be used repeatedly and safely. However, it is recommended to use the lowest pH detergent that provides a satisfactory result. When using water with any of the maintenance techniques listed, be sure not to leave any standing water and keep foot traffic off the floor until it is completely dry. Also, do not over-wet areas to be cleaned.

Do not use acetone, Pine-Sol® or citrus-based cleaners, as they can damage Plynyl. Solvents containing xylene or toluene may be used in a limited fashion as a spotting agent. See *Spot and Stain Removal*.



### Carpet

Vacuum the carpet on a regular basis. Use household carpet stain removers and cleaners to clean the carpet.



### Deck and Hull Finishes

Much of the finish surface of the hull and deck is a fiberglass-reinforced resin. While the boat material is sturdy, to ensure an enjoyable experience while boating, the fiberglass and resin layers, and gel coat finish (where the paint is embedded), is very thin—only a few millimeters in depth. To keep it looking like new, it is important to keep it clean and waxed. The finishes used by Cobalt are the finest available on the market today. However, the finish is not impervious to the elements and many types of water conditions, and attention must be given to care and maintenance on a regular basis.



### Cleaning the Deck and Hull

A multi-purpose boat soap (3M carries a complete line of fiberglass care products) should be used to clean the exterior fiberglass/gel coat surfaces on your Cobalt boat after each use. Avoid all harsh cleaners as they will quickly erode the finish.

A fiberglass restorer/wax should be used to remove heavy oxidation, characterized by a chalk/faded surface as well as rust and exhaust stains. This product will not only remove the oxidation, but also leaves wax protection on the cleaned surface in one easy application.

Paste wax will help retard UV light damage. Cobalt recommends applying three (3) coats of paste wax at the beginning of the season or the end of boating season, depending on the type of mooring or winter boat storage. If the boat will be exposed to the elements during boating season, additional care and waxing may be required to



retain the finishes.

Cobalt encourages boat owners to keep the boat covered and in an enclosed storage facility during the off-season or extended periods in-season when the boat is not being used. Again in mid-season, the boat should have the three-coat paste waxing maintenance; if the boat is frequently used, additional waxing may be necessary.

To extend the life of your gel coat finish, use a Cobalt marine mooring cover totally covering the top deck of the boat for maximum protection. Additionally, if your boat is to be stored where the sun is constantly on the side(s) or transom of the boat, you should consider having some custom skirting made to support the mooring cover.

Tonneau covers will supply adequate short-term protection to the interior but will not protect the gel coat finish.

Consult with your authorized Cobalt dealer for more information about adequate protection for the boat's finishes.



## Additional Cleaning Advice

When using specified products as directed on the cleaning container, all the surfaces of the boat (in addition to the vinyl and flooring care described above) should be cleaned and protected between each use. Be certain to also clean the engine as directed by the engine manufacturer. Always rinse and wipe off the finish with a damp towel or chamois cloth.

If you choose to wash the boat at a car wash, do so with care. Stay back from the boat surface to avoid potential damage from the high-pressure sprayer, and do not use the "soap" setting as most car-wash soaps are intended to deal with highway-type debris such as salt, road tar, and similar environmental hazards. Wash the boat by hand with mild soap as noted above, and then rinse carefully.

### NOTICE

**Harsh detergents and cleaners will quickly damage the finish, and this is not covered under warranty.**



## Swim Platform Mat Care and Maintenance

### General Cleaning

Regular cleaning can be accomplished by washing the mats with mild soap and water and using a medium-to-stiff bristled brush. Although the swim platform mat is stain-resistant, some things that would be expected to stain almost anything may stain the mats if left in contact with the mats for an extended period of time. It is always best to clean or rinse away any spills as soon as possible. Work the cleaner into the stain with a medi-

um-to-stiff bristle brush, brushing with the grain texture, and rinse with a hose to finish.

*Suggested cleaners:*

- Simple Green®
- Soft Scrub®
- Fantastik®
- Formula 409®

(Bleach may be used, but avoid any acid-based cleaners like FSR.)

*Things to avoid:*

- Sharp objects such as knives or tools dragged across the surface.
- Pressure washing due to the risk of shredding or cutting the mats.
- Extended contact with petroleum-based products. This can cause a stain that may not be removed.

### Storage

The swim platform mat is very resistant to most weather conditions including sun and rain. The life of the mats will be enhanced if the boat is stored either covered or indoors. It should be treated the same way you would treat vinyl marine seats or carpet in a boat. Excessive exposure to sunlight will decrease the life of the mats and result in fading.

### Focused Refracted Light

Much like a magnifying glass, certain things on a boat can cause focused light, which can result in blushing or burning of the surface on your swim platform mat. This is a very rare occurrence when the boat is in use, but if the boat is docked, on a lift or trailer, and the sun is at the correct angle, damage can occur. The best way to avoid this is to cover the boat when you are not using it.

If discolorization happens to your mats, they likely are not ruined. The damage usually looks like a wet spot (a little darker) and over time, this will blend or weather back into the rest of the mat area and become less noticeable.

### Material Note

The swim platform mat foam has a "memory." If you notice an indent in the mats when you remove your cover from the support pole or any other area where something with some weight has been sitting for an extended period, that mat will rebound over a short period of time back to its original shape.



## Teak Swim Platform

Your Cobalt boat may be equipped with a teak swim platform. To keep teak in top condition, clean it oc-

asionally with a teak cleaner and re-oil it at least once a season. Follow the manufacturer's instructions and warnings carefully. Some cleaners and oils may damage gel coat, vinyl, stainless or aluminum. Avoid using rust-producing steel wool pads when cleaning. Materials can be purchased from your authorized Cobalt dealer.

### NOTICE

**Teak sealers and cleaners can be harmful to other materials. Make sure you thoroughly remove any spills or excess. Teak should not be varnished. The natural oils in teak will cause poor adhesion.**



**DO NOT store cleaning cloths used to treat teak onboard. Store or dispose of cleaning cloths properly ashore.**

## Swim Platform (Non-Teak)

When teak has not been used, Cobalt uses other high-quality materials to construct swim platforms. These durable boards should also periodically receive a thorough cleaning. Use only mild detergents and warm water or marine industry-based cleaners that are approved for use in wet environments.

### NOTICE

**Avoid using unapproved products in attempting to clean. These will actually accelerate deterioration of the product, rather than protecting it. Such damage is not covered under warranty.**

## Windshield

To keep the windshield clean, use a non-abrasive glass cleaner applied with a soft cloth. Do not use harsh detergents, solvents, chemicals or dry cloths. These items will scratch the surface.

All the metal hardware, frame extrusions and stanchions should be carefully maintained as well, especially when operated in salt water operations.

## Bilge

Check the bilge after every outing and keep the bilge area as clean as possible. Due to the likely presence of water, use a Shop-Vac® or similar device to remove debris from the bilge area. Oil and greasy dirt, in addition to modest amounts of water that may not fully pump on through, will accumulate over time and normally can be

removed using soap and water. If necessary, consult an authorized Cobalt dealer for recommendations on special bilge cleaning and absorption products.

## Marine Growth

Remember that in various sections of this owner's manual information has been provided about the potential ill effects that can result in damaged equipment if attention is not paid to marine growth.

If marine growth is a problem in the area in which you are boating, it may be necessary to apply anti-fouling paint to the hull to slow growth and prevent gel coat damage. Consult an authorized Cobalt dealer for recommendations on how to do this properly.

## Stationary Arch with Awlgrip Topcoat

Your Cobalt boat may be equipped with a fixed, stationary arch with Awlgrip Topcoat.

It is difficult for dirt, grime and grease to adhere to Awlgrip 2000 Topcoat; however, over time, a buildup of dirt, grease and other contaminants can cause the finish to appear dull.

Maintaining your topcoat with a combination of Awlwash and Awlcare will deliver the best results.

The mirror-like gloss can be easily maintained by following these instructions:

### DO:

1. Wash the surface regularly with Awlwash 73234 and water. Regular cleaning will avoid buildup, which can slowly attack the topcoat, prematurely aging the coating.
2. Use only mild solvents to remove stubborn stains. Awlprep T0008, mineral spirits, xylene, and kerosene are acceptable for use on Cobalt's topcoat. Be certain to use with special care any flammable items and their fumes, keeping them at distance from flame sources. Apply solvents with soft, clean cloths. Wipe up solvent quickly. Do not allow solvent to dry on the surface or puddle and soak into the surface. Wash these areas with mild detergents and water to remove solvent residue.
3. Always thoroughly rinse all surfaces with fresh water after cleaning with detergents or solvents. Latent solvent residue can attack





- the topcoat, while detergent residue will attract dirt.
- Use distilled white vinegar and hot water to remove stubborn salt stains.
  - Use Awlcare 73240 by hand only to remove stubborn diesel soot stains.

**DO NOT:**

- Do not wax.  
*General:*  
Wax buildup ages and yellows very rapidly, creating the need to maintain the wax and causing the topcoat to appear yellow. Wax buildup also attracts dirt, increasing maintenance. Because waxing will help maintain the gloss, especially those areas which have been buffed or polished, some boat owners will chose to wax. Remember, waxing leads to having to maintain the wax from the initial application onward.  
If you choose to wax, do not wax areas unless they are dull or hazed.
- Do not use abrasives, scratch pads or polishing compounds. Scratching the surface gives dirt a place to cling while wearing out the resin layer. Using abrasives of any kind will reduce the overall life of the finish and voids the Awlgrip Limited Warranty.
- Do not allow contact between the topcoat and teak cleaners. Most teak cleaners contain acids or caustic agents that stain and discolor the topcoat.
- Do not use strong solvents (e.g., lacquer thinner,

- M.E.K., acetone) to clean the topcoat.
- Do not allow wet equipment (e.g., seat cushions, coils of line, or coolers) to trap and hold moisture against the topcoat. This condition can result in blistering or delamination of the Awlgrip topcoat.
- Do not use acrylic Teflon® (*Teflon is a registered trademark of E.I. du Pont de Nemours and Company*) coatings over an Awlcraft 2000 finish. Use of these coatings voids the Awlgrip Limited Warranty.
- Do not “shrink wrap” or tightly bind the top coat surfaces with plastic wrappings.

When tarping a boat for storage, the cover system should be ventilated to allow the coating system to “breathe.” Covers and tarps, whether synthetic or natural fiber, should not be pulled tight to surfaces painted with Awlcraft 2000 Topcoat. This condition can trap and hold moisture on the surface and result in loss of gloss, blistering or delamination of the topcoat.

Caution should also be used to ensure the tarp does not chafe against the Awlcraft 2000 surface. Such chafing, especially when accompanied by airborne dirt, can abrade the surface and cause premature loss of gloss.

**NOTICE**

**Failure to follow the instructions for care of the Awlgrip Topcoat as explained in this owner’s manual will void both the product’s and Cobalt’s limited warranties.**

## SCHEDULED MAINTENANCE AND SERVICE

**Your Cobalt boat may not include all of the features described in this section based on the options available and how your boat was built. If you have questions about component care beyond what is provided here, contact your authorized Cobalt dealer.**

### Steering System Maintenance Schedule



**The Teleflex® steering system must have all attaching hardware, bolts and nuts retorqued according to the manufacturer’s specifications after a few hours of operation and at regular intervals thereafter. Loose or missing hardware may cause failure of the steering system, resulting in injury or death. Due to the specific requirements to maintaining the steering system in optimum and safe functionality, have your authorized Cobalt dealer service the steering system at regular intervals.**

### Important General Information

Use the checks and maintenance information outlined in the section along with service information contained within the individual component operator’s manuals supplied with your boat. It is extremely important that you read and understand the periodic maintenance tasks outlined in your operator’s manuals (propulsion unit, generator and other accessories) because those maintenance tasks are not repeated in this manual.

Use the following chart to establish your maintenance routine. Detailed information concerning the task is listed in this section.





Frequency	Task
Break-in	Refer to propulsion unit operator's manual and the generator operator's manual, if equipped.
Before Every Use	<p>Test operation of carbon monoxide detectors.</p> <p>Check fluid levels.</p> <p>Check seacocks for leaks and ensure handles are secure.</p> <p>Check seawater strainers for leaks and accumulation of debris.</p> <p>Check generator's fuel/water separator, if equipped.</p> <p>Check exhaust system for leaks.</p> <p>Check fuel system for leaks.</p> <p>Check fire extinguisher.</p> <p>Check battery charge.</p> <p>Check equipment fasteners.</p> <p>Check there is sufficient fuel in the fuel tank for the outing.</p>
After Each Outing	<p>Check components.</p> <p>Note how much fuel and battery charge were used.</p> <p>Give the boat a good general cleaning.</p>
Every 50 Hours	<p>Clean seawater strainers, if equipped.</p> <p>Inspect propellers for damage.</p>
Every 100 Hours	<p>Test for proper operation of the ignition safety switch.</p> <p>Clean bilge area.</p>
Monthly	<p>Test GFCI outlets, if equipped.</p> <p>Check self-sacrificing anodes.</p>
Quarterly	<p>Have your authorized Cobalt dealer perform scheduled Maintenance as outlined in this section.</p>

## Break-In

Careful break-in allows internal engine components to “seal” properly, resulting in maximum engine life and performance. Refer to the propulsion unit operator's manuals, or the engine chapter of this owner's manual, for manufacturer's break-in requirements.

If the boat is equipped with a generator, refer to its manufacturer's operating manual for information regarding the break-in requirements.



## Before Each Use

1. Test for proper operation of the carbon monoxide detector (if equipped); refer to the carbon monoxide detector operator's manual.
2. Check fluid levels of the fresh water tank (if equipped), waste holding tank (if equipped) and trim tab reservoir.
3. Check the air conditioning and generator (if

equipped) seacocks and hoses for leaks. If you notice a leak, do not operate until you can see your authorized Cobalt dealer.



- Seacocks can be replaced only when the boat is out of the water.
  - Make sure a seacock is in the CLOSED position before replacing a hose.
4. Check the air conditioning and generator seawater strainers for leaks and accumulation of debris.
    - If a hose is leaking or damaged, close the appropriate seacock. Consult your authorized Cobalt dealer for repairs.
    - If debris is seen within the container, close the appropriate seacock and remove the strainer cover. The sea strainer serves the purpose of keeping debris from entering the raw water-cooling system and causing eventual engine failure. As with any kind



of strainer, it is necessary to regularly clean it so that water can flow unimpeded. Lift the strainer from the container and thoroughly clean it. If the container is full of sediment, remove the plug at the bottom of the container and allow water to drain into the bilge. Remove the container and clean any sediment. Install the container and plug. Install the strainer in the container and secure the cover. Open the seacock and check for leaks.

 **CAUTION**

The seacock must be in the **CLOSED** position before servicing a strainer.

**NOTICE**

Continuing to operate a boat that is overheating the engine and drivetrain will result in engine failure eventually. Boat operators should routinely review the engine temperature information. Ignoring or failing to take proper steps to reduce the engine temperature, resulting in damage, is not covered under the warranty.

5. Start the engine(s) and the generator (if equipped). Check all exhaust systems for leaks. If you notice a leak, do not operate the boat until you see your authorized Cobalt dealer and have the system(s) corrected.
6. Check all fuel lines and connections at fuel tanks, engines and the generator for leaks. If you detect a fuel leak, immediately see your authorized Cobalt dealer. Never start or operate a boat in the presence of a fuel leak. Fumes can cause an explosion and/or fire, which may lead to death or serious injury.

 **DANGER**

**Avoid the risk of fire or explosion. DO NOT operate your boat if a fuel leak is detected. All fuels are combustible. A fuel leak must be repaired before starting the engine(s) or the generator (if equipped).**

7. Check the portable and automatic fire extinguishers for proper charge.
8. Check the battery charge of both engine batteries. Be sure that the batteries can start the engine(s) and the generator, if equipped, before proceeding on your outing.

**If the posts show signs of corrosion or other debris, remove the battery and clean carefully. To do so, follow these steps:**

1. Turn the engine **OFF**, as well as any systems that are operating on the boat.
2. Make sure the battery switch is in the **OFF** position.
3. **Loosen and remove the negative (-) black terminal connection first. If you are using a wrench for this**

**process, be careful to avoid touching the positive (+) red terminal connection as you may receive an electrical shock as a result.**

4. **Next, loosen and remove the positive (+) red terminal connection.**
5. **Disconnect the hold downs that are holding the battery in place.**
6. **Remove the battery.**
7. **Using a battery terminal cleaner, carefully clean the corrosion/debris from the battery posts.**
8. **Using a baking soda and water mix, clean the battery case, taking care to avoid splashing any of the solution inside the battery vents. Rinse with clear water again, avoiding the vents.**

 **CAUTION**

Inside the battery is an electrolyte fluid that allows the chemical reaction to provide power. The fluid is comprised of several components, one of which is sulfuric acid. As with most acids, this is caustic and corrosive. If it comes in contact with skin, immediately flush the area with copious amounts of fresh, clean water. Follow up with medical assistance.

- A battery terminal brush may be necessary to remove corrosion from the inside of the battery terminals. Use the same type of baking soda and water mix and rinse with fresh water. Dry with a clean rag.
- Check the box in which the battery is held to be certain that it is not showing signs of corrosion or dirt. Clean, if necessary, as with the above instructions for cleaning the battery. Be sure that the holding box is dry prior to reinstalling the battery.
- Repeat the steps with the second battery.
- After placing the battery back in the holding box, reconnect the hold down. Then reconnect the positive (+) red battery cable connection first. Follow with the negative (-) black battery cable connection.
- Tighten both terminals and then coat with a thin covering of marine dielectric grease. Be sure that the positive terminal rubber boot completely covers the terminal.

 **DANGER**

**If it becomes necessary to re-charge a battery from an external source, DO NOT attempt to charge using automotive battery cables or use another boat battery as the source for charging. Some amounts of hydrogen gas are emitted during the charging process. This can be very dangerous. It is critical to keep all sparks, including smoking cigarettes, lighters, or any type of flame, well away from a charging battery. Use an optional battery charger sold by authorized Cobalt dealers, or a similar aftermarket battery charger. Using the wrong type of**



**charging procedure or improperly charging a battery can result in an explosion and/or fire that could lead to serious injury or death.**

9. Check equipment for loose or missing fasteners. Be sure all fasteners are installed and properly tightened before operating the equipment.
10. Fuel levels should be noted prior to an outing. Cobalt recommends starting all outings with a full tank and returning to shore to refuel regularly during a full-day's recreation as allowing fuel to fall too low in the tank can adversely affect the propulsion operation or could potentially strand the boat if fuel runs out.



### After Each Use Check Components

This is a common-sense approach. If you've been boating in dirty water, cleaning out the sea strainer now instead of waiting until the debris inside it has dried (and therefore becomes more difficult to remove) makes sense. You want to check the propeller to make sure it appears intact, too, especially if you suspect that you may have struck something submerged during the outing. This is an easy check after the boat has been loaded on the trailer and removed from the water.

Check anything else on the boat that did not function as expected during the outing and seek assistance from your authorized Cobalt dealer about any concerns and issues prior to the next outing.

### Note How Much Fuel and Battery Charge Were Used

Cobalt recommends keeping a chart or binder with information from your outing. If you note the conditions during the outing, the length of time, and the final readings, you'll have a much better idea of normal operations. That gives you the clues you need when readings are different, or you are anticipating an outing that will be different and you need to prepare for those conditions.

### Give the Boat a Good General Cleaning

*(Outlined in the Care information that precedes this section.)*

As noted earlier, ongoing care is important. Read that section to determine the normal expectations regarding routine care. Read the salt water maintenance information that appears earlier in this chapter. Even boating in "clean" water, you add protection and quality care for your boat by following the cleaning requirements. The same components that need added protection from salt/brackish water will also retain their luster and live longer if the same attention is applied to them after operation in fresh water.

### Every 50 Hours

1. Be sure to clean the seawater strainers as described in *Before Each Use, Step 4*, above.
2. Check the propellers for damage. If bends, cracks or other damage is found, consult your authorized Cobalt dealer for service. Do not continue to use damaged propellers as they may damage the drive unit(s) over time.



### Every 100 Hours

Clean the bilge area. Make sure all drain passages are clear. Refer to *Bilge* in the Care information earlier in this section of the owner's manual.



### Monthly



**The emergency safety switch and lanyard prevent the boat from becoming runaway if the operator is accidentally thrown from the helm. To test the system, with the engine(s) running, pull the lanyard off the emergency safety switch. The engine(s) must stop running. If the engine or engines do not stop running, immediately see your authorized Cobalt dealer for service. Never run your boat with an improperly operating emergency safety switch.**

1. Test the FGCI outlet circuit breaker feature, if equipped. Push the TEST button on each outlet. Power should be interrupted to all the outlets onboard. Press the RESET button to restore power. If power is not interrupted, consult your authorized Cobalt dealer.
2. Check the condition of all self-sacrificing anodes. If an anode shows deterioration of 50% or more, it must be replaced. Refer to the propulsion unit operator's manual for additional information, as well as the salt water care and maintenance information provided earlier in this section of the owner's manual.

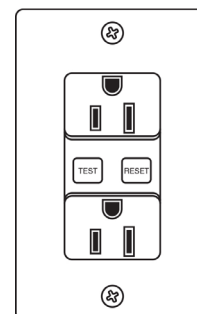

### Quarterly

Have your authorized Cobalt dealer perform the following scheduled maintenance (in addition to the two steps listed above under *Monthly*):

1. Clean the fresh water filter (if equipped).

2. Fill, pressurize and inspect the fresh water system (if equipped) for leaks and proper component operation.
3. Inspect the steering, shift and throttle systems for proper operation.
4. Check all batteries for proper electrolyte level.
5. Check the trim tab pump fluid level.



## Unscheduled Maintenance

Issues can arise with components at any time. Do not ignore malfunctions, collisions with debris or groundings, or anything occurring that is outside the normal operating range or expectations. Any matter that occurs requires your immediate attention; your authorized Cobalt dealer also stands ready to help identify and correct your concerns.



## Engine/Propulsion/Cooling System

If an unexpected issue occurs with the engine, propulsion unit or the cooling system between the scheduled maintenance cycles, immediately notify your authorized Cobalt dealer. Do not allow such situations to go unattended. What may be a minor repair if ignored could become a major repair.



## Electrical System

Have an authorized Cobalt dealer repair all electrical problems. Due to the complexity of a boat's wiring and the necessity of a properly functioning electrical system to ensure the propulsion system works properly and does not strand a boat, every electrical concern should be taken seriously.



**Whenever checking for electrical problems, use extreme caution. An electrical spark could ignite fuel fumes and cause a fire or explosion.**



## Fuel System

**DO NOT** operate a boat if you suspect or detect a fuel system issue. Upon discovery of a fuel system concern, immediately notify an authorized Cobalt dealer for repair. Never operate a boat if you suspect a potential fuel/fume issue exists.



**DO NOT** operate your boat when a fuel leak is detected. **All fuels are combustible. A fuel leak must be repaired before starting the engine(s) or the generator (if equipped.)**



## Water System (if equipped)

### Fresh Water

Before departing on a cruise, check the level of fresh water onboard. Fill the fresh water tank and the proper operation of the fresh water system. If a problem is found, have it repaired at your earliest convenience.

### Cleaning and Disinfecting the Fresh Water System

For potable (drinking) water, follow these steps to disinfect the water tank and system before the first use and prior to the boating season every year. Repeat the process as often as needed.

These steps involve filling the fresh water tank with a solution of household bleach and water (see below) and running the solution through each faucet, and then letting it stand for at least three (3) hours.

Finally, flush the system once or twice to remove any residual taste and smell of bleach.

1. Start with a nearly full fresh water tank.
2. Turn the water heater off (if applicable) and let the water cool.
3. Dilute four (4) tablespoons of household bleach for each ten (10) gallons of tank capacity into one (1) gallon of water.
4. Add the chlorine/water solution to the water tank. **(Never pour straight bleach into the fresh water tank.)**
5. One faucet at a time, let the chlorinated water run through them for one (1) or two (2) minutes. (Hot water will take longer due to added time to run through the hot water tank.) You should be able to smell the chlorine. (To be sure that you are circulating the cleansing water throughout the fresh water system, be certain you are using the water pump and not an external water supply.)
6. Top off the fresh water tank and let stand for at least three (3) hours. Overnight is better.
7. Completely drain the system by flushing the faucets for several minutes each. Open the fresh water tank drain valve to speed up emptying the tank, and open the hot water tank drain plug (if applicable) and drain until it is empty.
8. Close all valves and faucets and install all drain plugs.
9. Fill the water tank with fresh water.
10. Flush the faucets for several minutes each, repeating until the tank is again empty. (As noted above, be sure you are using the water pump and not an external water supply.)
11. Fill the tank again. The water should now be safe to drink. If you are uncertain or if the chlorine odor is too strong, you can repeat the freshwater flush.

## Gray Water

Periodically check the level of waste water in the waste tank. Have your waste tank pumped out when

needed and be sure that the waste system is always operating properly. Additional details appear elsewhere in this owner's manual.

# STORAGE AND WINTERIZATION

## Lifting the Boat

To prevent structural damage to your Cobalt boat, the proper procedure must be used when lifting your boat. Remove boats from the body of water only by way of a trailer that has been designed for your boat or by lifting slings. Incorrect trailer fit or any lift that is not properly rated for the weight of the boat means that there will be undue stress on the boat's structural unit. Over time, these components could potentially fail, which would not be covered under warranty.

### NOTICE

**Never use the tower or arch as part of the lifting process. These components are not designed to be utilized at any time or any point in the lifting process. Never lift the boat with any water in the ballast or bilge systems of the boat. The additional weight could cause failure also, and such resulting damage is not covered under the limited warranty.**



## Using Lifting Slings

When using slings, an appropriately rated capacity overhead hoist is required. Slings must be the flat, wide-belt type. Do not use cable-type slings. The spreader bars used with the slings must be wide enough to avoid pressure to the gunwales. Multiple slings at least six (6) inches wide by twenty (20) feet should be used.

If your Cobalt boat has sling location decals on each side of the hull to indicate where each sling should be located, use them to position the slings. If your boat does not have decals, contact your authorized Cobalt dealer to identify the proper location for slings. Slings may need to be adjusted forward or aft for your particular boat.

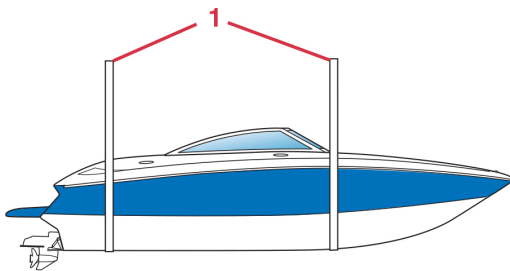

1 – Flat, wide-belt sling

COB\_0080\_A

## Storage Cradle

Use only a storage cradle (or the trailer designed for your boat) to store your boat when it is not in the water. A storage cradle or your boat's trailer will provide proper support and prevent stress on the hull.

A storage cradle must provide proper support to the boat, meaning the boat cannot be supported by resting the hull on the keel. There can be no gaps between the hull and the cradle supports. Support of at least five hundred (500) square inches is required on boats of less than twenty-five feet (25'), and at least six hundred (600) square inches on boats greater than twenty-five feet (25').

Position the storage cradle as close to the sling tag locations as possible. Use caution not to damage any underwater fittings.

Protect all underwear gear protruding from the boat hull from damage. None of these components is rated to support any of the boat's weight. The storage cradle must completely touch the hull for proper support. Avoid any gaps between the cradle and the hull.

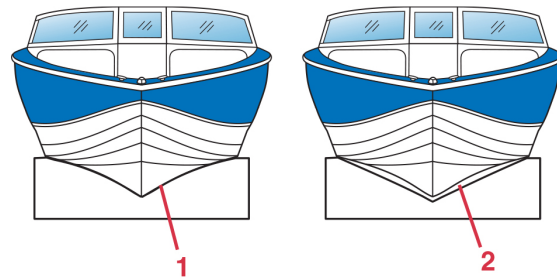

1 – Hull completely on cradle — right  
2 – Gap between hull and cradle — wrong

COB\_0081\_A

Store your Cobalt boat on a storage cradle with the bow slightly elevated, the same attitude as if the boat were floating at rest. If the boat is stored with the bow down, moisture will not be able to move to the engine bilge area and out of the boat.

Remove the transom drain plug. (Cobalt suggests placing drain plugs in a clear, plastic bag and storing at the steering wheel or driver's helm to help remember to reinstall the plugs when the boat is recommissioned.)

Be sure that all compartments in the bilge completely drain. Mold and mildew may form as a result of the inability of moisture to escape. In certain geographic regions, particularly when boats are stored in unheat-

ed areas, water can freeze inside the lines or bilge and cause damage that is not covered under warranty.



## Storage/Winterization General Information

Preparing for winter lay-up is important. In frigid zones, be particularly attentive to items that can be damaged by freezing. Freeze damage is not covered by warranty.

The following items require special attention for winterization. Your Cobalt boat may not include all the features described. Have your authorized Cobalt dealer perform winterization procedures for the following:

- Engine cooling and exhaust systems (review storage and winterization requirements as noted in the engine/ propulsion unit's owner's manual)
- Fuel system
- Batteries
- Air conditioning
- Generator and muffler (review storage and winterization requirements as noted in the propulsion unit's owner's manual)
- Waste water system
- Fresh water system
- Gray water system
- Cockpit heater

After the boat has been properly positioned on a storage cradle, thoroughly wash the hull, deck and interior compartments. Allow a couple of days of air drying before covering the boat, store all cushions in the **OPEN** position and open all storage areas. This will help prevent mold/mildew from forming. Perform preventive maintenance to the interior and exterior of your boat, following the information in this section of the owner's manual.

Cover the boat with the mooring cover. If a temporary poly cover, such as shrink wrap, is used, your authorized Cobalt dealer must install several vents to provide adequate ventilation to prevent mold or mildew.

### NOTICE

**For stowage, Cobalt recommends an optional mooring cover of 100% SharkSkin™ polyester. DO NOT use your tonneau cover for long-term storage. These canvases were not designed for long-term storage and do not provide good extended protection for your boat. Adequate ventilation is not possible, and mold/mildew will form. For more information on appropriate covering for long-term storage, see your authorized Cobalt dealer.**



## Reactivating the Boat After Storage

Have your authorized Cobalt dealer prep your boat for the upcoming boating season. There are many systems that require special attention to ensure your boat is in proper operating condition.

- Carbon monoxide detector(s), if equipped
- Fuel and exhaust systems
- Engin's cooling exhaust and lubrication systems
- Air conditioning
- Generator and muffler
- Fresh water system
- Waste water system
- Gray water system
- Batteries

It is very important that all fuel systems and exhaust systems be thoroughly inspected and repaired, if necessary, before operating the boat. Also, any accessory exhaust systems must be in proper operating condition.

Be sure to check all onboard equipment for loose or missing fasteners. Do not operate the equipment if the fasteners are loose or missing.



**Inspect and repair the fuel system as necessary. Failure to inspect the fuel system, which could allow fuel leaks to go undetected, can contribute to a fire or explosion hazard.**



**Exposure to carbon monoxide (CO) can cause severe injury or death. CO is a naturally occurring by-product of gasoline engines. CO is colorless, odorless and quickly dangerous. Direct and prolonged exposure to CO will cause brain damage or death, among many adverse effects. Signs of exposure to CO include nausea, dizziness and drowsiness. Avoid exposing your passengers or yourself to carbon monoxide.**





# Warranty Statements



# COBALT CERTIFICATE OF LIMITED WARRANTY

Subject to the terms, conditions, and exclusions in this warranty, Cobalt Boats, LLC, a Delaware limited liability corporation doing business as Cobalt Boats ("Cobalt"), warrants to the original retail purchaser (and any subsequent owner) ("Owner") of a new Cobalt boat purchased from an authorized Cobalt dealer for personal, non-racing and non-commercial use, as follows:

**Ten (10) Year Limited Transferable Warranty on Hull and Deck.** Cobalt warrants to the Owner that the hull and deck, including floor, stringers, bulkheads, motor mounts, transom and deck/hull joints of a new Cobalt boat are free from structural defects in material and workmanship under normal, non-racing and non-commercial use for a period of ten (10) years from the date of delivery to the original retail purchaser.

**Five (5) Year Limited Transferable Bow to Stern Component Warranty.** Cobalt warrants that the upholstery, canvas, components (excluding hull and deck structural components), where purchased or manufactured by Cobalt, with respect to a new Cobalt boat are free from structural defects in material and workmanship under normal, non-racing and non-commercial use for a period of five (5) years from the date of delivery to the original retail purchaser.

**Three (3) Year Limited Transferable Warranty on Gelcoat Finish.** Cobalt warrants that the gelcoat finish, with respect to a new Cobalt boat is free from defects in material and workmanship under normal, non-racing and non-commercial use for a period of three (3) years from the date of delivery of such Cobalt boat to the original retail purchaser. Because local area operating conditions and customer care have an effect on gelcoat finishes, the gelcoat finish warranty does not cover (1) damage or deterioration (for example: fading, oxidation, discoloration) due to in-water storage or improper care of the gelcoat surface; or (2) deterioration (for example: fading, oxidation, discoloration) to the gelcoat finish of any Cobalt boat with colored (non-white) gelcoat located below the static waterline; or (3) blisters due to in-water storage without the proper application of a marine barrier coating to the bottom of the hull.

**THERE ARE NO EXPRESS WARRANTIES OTHER THAN THE ABOVE LIMITED EXPRESS WARRANTIES. TO THE EXTENT APPLICABLE, ANY IMPLIED WARRANTIES, INCLUDING ANY IMPLIED WARRANTIES OF MERCHANTABILITY OR FITNESS FOR PARTICULAR PURPOSE, WILL NOT**

## **EXTEND BEYOND THE DURATION OF THESE EXPRESS WRITTEN WARRANTIES.**

Some states do not allow limitations on how long an implied warranty lasts, so the above limitation may not apply to you.

**Exclusions.** The above described limited warranties do not apply (1) if such Cobalt boat has been used at any time commercially, industrially, for racing or other competition or for revenue producing purposes; (2) to engines, outdrives, propellers, controls (each of which may be separately warranted by the engine manufacturer thereof); (3) engines, outdrives, propellers, controls, batteries, trailers, equipment or accessories installed by persons or parties other than Cobalt or an authorized Cobalt dealer; (4) windshield leakage, rainwater leakage, windshield or window damage or breakage; (5) deterioration or damage, fading or shrinkage of upholstery, carpet or canvas; (6) damage related to the alteration or modification of such Cobalt boat with any structurally affecting addition, component or accessory not specifically in accordance with Cobalt's specifications or offered as an option by Cobalt; (7) damage, deterioration (for example: fading, oxidation, corrosion) of surface finishes, vinyls, fabrics, aluminum and stainless steel finishes; (8) damage or failures caused by operation of the Cobalt boat outside of the maximum horsepower specifications recommended by Cobalt; (9) damage or failure related to repairs made by any service provider not approved by Cobalt; (10) damage (for example: scratches, fading, oxidation, discoloration) to the gelcoat finish; (11) deterioration (for example: fading, oxidation, discoloration) to the gelcoat finish of any Cobalt boat with colored (non-white) gelcoat located below the static waterline; or (12) damage or failure related to alteration, modification, misuse, neglect, negligence, accident or failure to provide reasonable care and maintenance of such Cobalt boat.

## **Remedies.**

**General.** During the applicable limited warranty period, as set forth above, covered warranty repairs shall be made and any replacement parts or components used as part of such warranty repairs shall be provided without charge by an authorized Cobalt dealer or, at the option of Cobalt, by Cobalt at its plant in Neodesha, Kansas, or at a facility specifically authorized by Cobalt. All warranty repairs and replacement parts or components shall be subject to the authorization of factory trained

personnel of Cobalt. Transportation to and from an authorized Cobalt dealer, and/or to and from the Cobalt plant in Neodesha, Kansas, for warranty repairs, shall be at Owner's expense.

**Service Assist Service Agreement (see Addendum A).** Service Assist is not covered under this limited warranty. Service Assist is covered under the separate Service Assist Service Agreement.

The rights and benefits granted under the above described limited warranty extend to (1) the original retail purchaser of a new Cobalt boat, and (2) any owner of such Cobalt boat during the applicable warranty period, commencing with the date of delivery of such Cobalt boat to the original retail purchaser, provided that such limited warranty is validated, as set forth herein.

**COBALT'S ONLY RESPONSIBILITY, AND THE OWNER'S ONLY REMEDY, IS AS DESCRIBED IN THIS WARRANTY. COBALT SHALL NOT BE LIABLE FOR INCIDENTAL, CONSEQUENTIAL, INDIRECT OR SPECIAL DAMAGES.**

Some states do not allow the exclusion or limitation

of incidental or consequential damages, so the above exclusions may not apply to you. This warranty gives you specific legal rights, and you may also have other legal rights which vary from state to state.

**How to Obtain Warranty Service.** To validate the above described limited warranty, (1) the authorized Cobalt dealer must complete the warranty registration process with Cobalt Boats at 1715 N. 8th Street, Neodesha, KS 66757, within ten (10) days after purchase of a new Cobalt boat, and (2) any subsequent owner of a Cobalt boat during the applicable limited warranty period must give written notice of the acquisition of a Cobalt boat to Cobalt within ten (10) days after such purchase. Notification of any warranty claim arising within the applicable warranty period, as set forth above, must be made in writing by the owner of such Cobalt boat or by an authorized Cobalt dealer to Cobalt within thirty (30) days after the discovery of the alleged basis for any warranty claim. With respect to any condition for validating a limited warranty or obtaining any remedy, the authorized Cobalt dealer is Owner's agent, and Owner is solely responsible for and bears the risk for the authorized Cobalt dealer's failures.

## ADDENDUM A—SERVICE ASSIST SERVICE AGREEMENT

In consideration of the purchase of a new Cobalt boat from an authorized Cobalt dealer for personal, non-racing, and non-commercial use, for the term of this agreement Cobalt Boats, LLC ("Cobalt") agrees to provide to the original retail purchaser or any subsequent owner (each an "Owner") of such Cobalt boat, for which the registration process under Cobalt's Certificate of Limited Warranty has been completed, the services described in this agreement.

**Obligation.** Subject to the conditions and limitation of this agreement, if (1) Owner makes a valid claim under either the Cobalt Five (5) Year Bow to Stern Component Warranty or any express warranty made by the engine manufacturer with respect to the engine or powertrain of such new Cobalt boat (the "Applicable Warranties"); (2) Owner incurs costs for on-water towing, hoist/lift-out, haul-out, or dockside repair call ("Covered Services") in association with such claim; and (3) the Applicable Warranties claim is made and Covered Services costs are processed through an authorized Cobalt dealer ("Dealer"), then Cobalt will reimburse Owner for or pay such costs.

**Conditions.** As a condition for Cobalt's obligations under this agreement, if Covered Services are provided by anyone other than a Dealer, Owner must provide the following documentation (as applicable) to the Dealer prior to the time the Dealer submits the Applicable Warranty claim:

- Copy of Towing, Hoist/Lift Out, Haul-Out or Dockside Repair bill
- Copy of warranty claim to the engine manufacturer

**Limitations.** Cobalt's liability under this agreement will not exceed a maximum of \$100 per claim. **EXCEPT AS PROHIBITED BY APPLICABLE LAW, COBALT MAKES NO WARRANTIES, EXPRESS OR IMPLIED, UNDER THIS AGREEMENT OR REGARDING THE SERVICES, INCLUDING WITHOUT LIMITATION, THE IMPLIED WARRANTIES OF MERCHANTABILITY OR FITNESS FOR A PARTICULAR PURPOSE. COBALT WILL NOT BE LIABLE FOR INCIDENTAL, CONSEQUENTIAL, INDIRECT OR SPECIAL DAMAGES.** Some states do not allow the exclusion or limitation of implied warranties or limitation of remedies for their breach, so the above provision may not apply to you. This agreement gives you specific legal rights, and you may also have other legal rights which vary from state to state.

**Term.** This agreement begins on the original purchaser delivery date of the new Cobalt boat and is effective through the end of the warranty periods for the Applicable Warranties.

**Assignment.** This agreement is transferable to subsequent Owners within the term of this agreement. Other-

wise, Owner may not transfer or assign any of Owner's rights, title, or interest under this agreement.

**General.** This agreement embodies the entire understanding of the parties. This agreement cannot be changed or modified except in writing signed by an authorized officer of Cobalt. This agreement is governed

by the laws of the State of Kansas, ignoring the rules on conflicts of law. No failure or delay by Cobalt to exercise any right or remedy will operate as a continuing waiver. Headings used in this agreement will have no legal significance. This agreement will not be construed against a party simply because the party may have drafted such provision.

## CALIFORNIA EVAPORATIVE EMISSIONS CONTROL SYSTEM WARRANTY STATEMENT

### Your Warranty Rights and Obligations

The California Air Resources Board is pleased to explain the evaporative emission control system's warranty on your Cobalt Boat. In California, new spark-ignition marine watercraft (SIMW) must be designed, built, and equipped to meet the State's stringent anti-smog standards. Cobalt Boats, LLC must warrant the evaporative emission control system on your boat for the period listed below provided there has been no abuse, neglect or improper use of your SIMW.

Your evaporative emissions control system may include parts such as: canisters, carburetors, clamps, connectors, filters, fuel caps, fuel lines, fuel tanks, valves, vapor hoses, and other associated evaporative emissions control system components.

### MANUFACTURER'S WARRANTY COVERAGE:

This evaporative emission control system is warranted for two years. If any evaporative emission-related part on your SIMW is defective, the part will be repaired or replaced by Cobalt Boats, LLC.

### OWNER'S WARRANTY RESPONSIBILITIES:

- As the boat owner, you are responsible for performance of the required maintenance listed in your owner's manual. Cobalt Boats, LLC recommends that you retain all receipts covering maintenance on your boat, but Cobalt Boats, LLC cannot deny warranty solely for the lack of receipts.
- As the boat owner, you should however be aware that Cobalt Boats, LLC may deny you warranty coverage if your spark-ignition marine watercraft or a part has failed due to abuse, neglect, or improper, maintenance or unapproved modifications.

- You are responsible for presenting your boat to a Cobalt Boat, LLC distribution center or service center as soon as the problem exists. The warranty repairs should be completed in a reasonable amount of time, not to exceed 30 days. If you have a question regarding your warranty coverage, you should contact Cobalt Boats, LLC at 1-(620) 325-2653.

The California evaporative emissions control system warranty covers the following list of components:

- (1) Canister Mounting Brackets
- (2) Carbon Canister
- (3) Carburetor Purge Port Connector
- (4) Clamps\*
- (5) Control Cables\*
- (6) Control Linkages\*
- (7) Control Solenoids\*
- (8) Control Valves\*
- (9) Electronic Controls\*
- (10) Fuel Cap
- (11) Fuel Line
- (12) Fuel Line Fittings
- (13) Fuel Tank
- (14) Liquid/Vapor Separator
- (15) Pressure Relief Valves\*
- (16) Purge Valves
- (17) Vacuum Control Diaphragms\*
- (18) Vapor Hoses
- (19) All other parts not listed that may affect the evaporative emissions control system

*\*Your craft may or may not be equipped with these components.*

**The following warranty statements for Monsoon Engines apply to ONLY those brands of engines. Applicable warranty statements for other brands will be provided separately by the manufacturers. Boats**

**equipped with the Mercury Outdrive will also have the warranty statement as provided by Mercury separately from this document.**

# MONSOON ENGINES LIMITED WARRANTY STATEMENT

## **Section 1: Certain Limitations and Disclaimer of Implied Warranties**

THE LIMITED WARRANTY SET FORTH HEREIN IS IN LIEU OF ALL OTHER WARRANTIES AND REPRESENTATIONS, EXPRESS OR IMPLIED, AND TO THE MAXIMUM EXTENT PERMITTED BY APPLICABLE LAW. MALIBU BOATS, LLC DISCLAIMS, AND THE PURCHASER HEREBY EXPRESSLY WAIVES, ANY AND ALL OTHER WARRANTIES OR REPRESENTATIONS OF ANY KIND OR NATURE, INCLUDING, BUT NOT LIMITED TO, IMPLIED WARRANTIES OF MERCHANTABILITY AND FITNESS FOR A PARTICULAR PURPOSE, OTHER THAN THOSE WARRANTIES WHICH ARE IMPLIED BY, AND ARE INCAPABLE OF EXCLUSION, RESTRICTION OR MODIFICATION UNDER APPLICABLE LAW. THERE ARE NO WARRANTIES WHICH EXTEND BEYOND THE DESCRIPTION OF THE FACE HEREOF. ANY IMPLIED WARRANTY THAT IS FOUND TO ARISE BY STATE OR FEDERAL LAW, INCLUDING ANY IMPLIED WARRANTY OF MERCHANTABILITY OR ANY IMPLIED WARRANTY OF FITNESS, IS LIMITED IN DURATION TO THE DURATION SET FORTH IN THIS LIMITED WARRANTY OR THE DURATION SET FORTH BY APPLICABLE STATE OR FEDERAL LAW, WHICHEVER IS SHORTER.

PERFORMANCE OF REPAIRS AND NEEDED ADJUSTMENTS IS THE EXCLUSIVE REMEDY UNDER THIS LIMITED WARRANTY, WITHOUT EXCLUSION, MODIFICATION OR RESTRICTION, OTHER THAN UNDER APPLICABLE LAW. MALIBU BOATS, LLC SHALL NOT BE LIABLE FOR INCIDENTAL OR CONSEQUENTIAL DAMAGES, SUCH AS, BUT NOT LIMITED TO, LOST WAGES, SLIP FEES, TRANSPORTATION TO OR FROM REPAIR, OR RENTAL EXPENSES, RESULTING FROM BREACH OF THIS WRITTEN WARRANTY OR ANY IMPLIED WARRANTY, OR OTHERWISE, EVEN IF MALIBU BOATS, LLC HAS BEEN ADVISED OF OR SHOULD HAVE FORESEEN THE POSSIBILITY OF SUCH DAMAGES, AND EVEN IF ANY MALIBU BOAT OR COMPONENT PART THEREOF FAILS OF ITS ESSENTIAL PURPOSE. THIS EXCLUSIVE REMEDY SHALL NOT BE DEEMED TO HAVE FAILED OF ITS ESSENTIAL PURPOSE AS LONG AS MALIBU BOATS, LLC IS WILLING AND ABLE TO REPAIR OR REPLACE ANY DEFECTIVE GOODS SUBJECT TO THE TERMS PROVIDED HEREIN. UNDER ANY CIRCUMSTANCE, THE ENTIRE LIABILITY OF MALIBU BOATS, LLC IS LIMITED TO THE LESSER OF THE REPAIR OR REPLACEMENT OF ANY DEFECTIVE COMPONENT OR AFFECTED PORTION OF THE MONSOON ENGINE, OR THE ACTUAL PRICE PAID FOR THE MONSOON ENGINE.

**SOME STATES DO NOT ALLOW LIMITATIONS ON TIME LIMITS OR EXCLUSIONS OF INCIDENTAL OR CONSEQUENTIAL DAMAGES, SO THE ABOVE LIMITATIONS MAY NOT APPLY TO YOU. THIS LIMITED WARRANTY GIVES YOU SPECIFIC LEGAL RIGHTS WHICH MAY VARY FROM STATE TO STATE, BY JURISDICTION, AND COUNTRY. TO THE EXTENT THAT YOUR STATE DOES NOT ALLOW ANY EXCLUSION OR LIMITATION EXPRESSED HEREIN, SUCH EXCLUSION OR LIMITATION WILL NOT APPLY TO YOU. ALL OTHER ALLOWABLE LIMITATIONS OR EXCLUSIONS SHALL APPLY TO YOU.**

## **Section 2. The Limited Warranty Application and Terms; Transferability**

Malibu Boats, LLC (“Malibu Boats”), warrants to the original user or purchaser, whoever comes first (hereafter the “Purchaser”), that each new and unused Monsoon Engine, where applicable (“Monsoon Engine”), shall under normal authorized use remain free from defects in craftsmanship and materials during the applicable warranty periods, in accordance with and subject to the terms, conditions and limitations as described in this Limited Warranty. Any and all references to Monsoon Engines within this document refer to only those engines, complete or component, which are manufactured by Malibu Boats, LLC, parent company for Monsoon Engines. Cobalt Boats equipped with drive trains, complete or component, manufactured by outside suppliers are covered under, and subject to, limitations and time duration as described within the limited warranty statements provided by the supplier.

Subject to all other terms, conditions, and limitations, 1) original Purchaser(s) of the Monsoon Engine and, 2) second owners of the Monsoon Engine who purchase the boat within five (5) years of the earlier of (a) the date the boat was purchased by the first retail purchaser through an authorized Cobalt Boats Sales facility, or (b) the date the boat was first put into service as a demonstrator or other use except for commercial purpose (from which there is no transferability of the limited warranty), and qualify for and complete a warranty transfer as explained below, are provided coverage under the Monsoon Engines Limited Warranty.

**Note: This Limited Warranty is expressly conditioned upon the timely completion and return of the warranty registration card to Cobalt Boats. Although not obligated to and without creating such an obligation, this will enable Cobalt Boats to notify you of any necessary**



**performance or safety modifications to your Monsoon Engine, and to verify ownership in case a warranty claim is filed on your Monsoon Engine.**

The Limited Warranty is expressly subject to the following terms, conditions, and limitations. All warranty applications are dependent upon the Purchaser following the guidelines established for appropriate and reasonable care and maintenance of the Monsoon Engine and operating his or her Monsoon Engine reasonably and as directed in this Owner’s Manual, and as directed in any additional directions and/or owner’s manuals relating to any specific component part or parts of the Monsoon Engine (the “Guidelines and Directions”). **Purchaser’s failure to follow such Guidelines and Directions shall void this Limited Warranty.**

All repairs performed by Cobalt Boats, or its authorized service facilities, will be performed using either new or re-manufactured parts. Cobalt Boats and/or Monsoon Engines may, at their option, install parts which have substantially similar or greater performance characteristics if an identical replacement part is no longer available.

No person or entity is authorized to make any additional or revised statement or warranty, express or implied, on behalf of Monsoon Engines or any component supplier beyond what appears within this Limited Warranty.

**Limited Warranty Summary:**

<b>Coverage Type</b>	<b>Coverage Period (from date of original retail purchase or initial use of the Monsoon Engine, whichever first occurs)</b>
<b>Engine Limited Warranty</b>	<b>Earlier of Sixty (60) Months or 500 hours—fresh water boats</b> <b>Earlier of Thirty-six (36) Months or 300 hours—salt water boats</b>

The repair and/or replacement of components or parts under warranty does not extend the warranty period beyond the original expiration date.

For a period of sixty (60) months or 500 hours, whichever is earlier, for fresh water boats, and thirty-six (36) months or 300 hours for salt water boats, beginning on the date of the original retail purchase or the initial use of the Cobalt Boat, whichever occurs first, Monsoon Engines will repair or replace materials or workmanship supplied by it during construction of the Cobalt Boat, including parts and labor, which are determined by Monsoon Engines to contain substantial manufacturing defects.

This Limited Warranty does not provide coverage for any

component part that is at any time covered by any warranty provided by any third party, other than Monsoon Engines, including, but not limited to the manufacturer of the component part. Component parts shall include, but are not necessarily limited to, any items that are fastened to the boat through either mechanical means (screws/bolts) or chemical means (adhesives), which may or not be manufactured by Monsoon Engines. In the event that any warranty coverage for any component part is rendered or deemed void due to actions of the Purchaser or any third party other than Monsoon Engines, this Limited Warranty will not provide warranty coverage for the component part.

**Section 3: Limited Warranty Exclusions and Limitations**

In addition to any prior limitations and exclusions, the following are **NOT** covered under this Limited Warranty:

- normal maintenance of the Monsoon Engine or any component thereof;
- normal wear-and-tear of the Monsoon Engine or any component thereof;
- damages or needed adjustments caused by items that are added, altered or changed after the Monsoon Engine leaves the possession of Cobalt Boats;
- modification, alteration, unauthorized repair or replacement of components, including but not limited to damages resulting from such installations, on the Monsoon Engine;
- damages caused by accident (including impacts and collisions with any object), abuse, misuse, neglect, negligence, mishandling or alteration, including any damages caused by or during trailering or towing;
- damages caused by heat, fire, explosion or freezing (including the failure to perform proper winterization or preparations for storage or lack of use for periods in excess of thirty [30] days);
- damages caused by atmospheric fallout, chemical treatments, tree sap, salt, ocean spray, mold, or animal droppings, lightning, hail, rain, flooding, wind, sand, floods or other environmental or natural conditions or Acts of God;
- damages caused by vandalism or theft;
- **failure to follow the instructions within this Owner’s Manual regarding corrosion prevention and operation in salt or brackish water may result in or contribute to damage and are not covered under the Limited Warranty;**
- damages caused by aftermarket cleaning products or additives not specifically approved by Monsoon Engines;
- damages due to insufficient or improper maintenance, lack of maintenance, or delay of repair

(unless specifically and directly authorized by Cobalt Boats warranty department in writing);

- damage or contamination resulting from leaking or spilled fluids including, but not limited to, fuel or drive train fluids;
- conditions resulting from use of the boat for anything other than recreational purposes (Note: Commercial use as described in this owner's manual will affect the length of warranty coverage. Please refer to *Section 5: Commercial Use Exclusions / Restrictions* for specific details);
- manufacturing variations or imperfections in cosmetic, convenience or aesthetic components or features which have no effect on use or safety;
- damages caused by improper weight distribution or excessive weight combinations of persons aboard, ballast or simulated ballast and gear;
- any material, component or part of the boat that has a warranty period and/or conditions as specified by the producing entity which differs from this Limited Warranty unless such warranties are administered directly by the producing entity;
- damages caused by water intrusion into any part of the Monsoon Engine where water circulation is not part of the normal operation;
- performance characteristics, such as speed, acceleration, fuel or oil consumption, etc., as they are estimated and can vary as dictated by individual conditions;
- any and all consequential damages including, but not limited to, costs incurred for haul-out, launching, towing, storage charges, telephone, expedited shipping of replacement parts, or rental charges of any type (including slip fees), inconveniences, or loss of time or income;
- damage or injury resulting from failure to comply with recall notices, service bulletins and advisories, or requests from Cobalt Boats and/or Monsoon Engines to repair the boat or its components;
- damage or injury resulting from speeding, demonstration or any type of racing;
- damages resulting from the failure to properly maintain and care for the Monsoon Engine and its components in accordance with the instructions found within this Owner's Manual;
- shop supplies used in correction work, such as, but not limited to, sealants, lubricants, cleaning supplies;
- minor adjustments to the drive train, such as, but not limited to, investigation of components, cleaning or adjusting spark plugs, verification of fluid levels and lubricants, controls for the drive train;
- damage to water pump impellers, or any component of the cooling system that Monsoon Engines determines at its sole discretion could have been avoided

either through reasonable boating operation and practices or by maintenance as required and directed in this Owner's Manual;

- damage to the engine starter motor or other assemblies and components determined by Monsoon Engines at its sole discretion are the result of excessive attempts to start the engine, or by condensation/submersion of these and similar components;
- damage resulting from water intrusion in the intake or exhaust system;
- damage resulting from the use of lubricants, gasoline, or other fluids other than those specified in this Owner's Manual or by subsequent approval by Monsoon Engines following publication of this Owner's Manual;
- damage to the drive train resulting from a lack of sufficient cooling or the drive train operation outside a sufficient body of water to provide adequate cooling, or cooling failure resulting from blockage by foreign objects;
- damage resulting from erroneous service by the customer or technician not authorized by Cobalt Boats and/or Monsoon Engines to perform service or corrections;
- damage that cannot be traced to material defects in materials or workmanship, as determined by Monsoon Engines.

#### **Section 4: International Exclusions/ Requirements**

Importing or exporting any Monsoon Engine ("US Monsoon Engine") manufactured in the United States into Australia or New Zealand immediately and completely voids any and all coverage provided under this Limited Warranty and any and all obligations owed by Monsoon Engines relative to the US Monsoon Engine. This Limited Warranty does not provide coverage to any Monsoon Engine purchased from a dealer in another country where the primary use of the Monsoon Engine will require the Monsoon Engine to cross an international border. The Limited Warranty will not be honored by Monsoon Engines that is acquired by the Purchaser through an international cross-border purchase. All repairs that are covered under this Limited Warranty must be performed in the country where the Monsoon Engine was originally purchased.

#### **Section 5: Commercial Use Exclusions/ Restrictions**

The use of any Monsoon Engine for commercial purposes, including but not limited to as a demonstrator, or in connection with any promotional program, ski, wakeboard, or surf school or show ("Commercial Purposes") shall alter the Limited Warranty as set forth herein. The Limited Warranty applicable to any Monsoon Engine



used for any Commercial Purpose may not be transferred to any subsequent owner of the Monsoon Engine. The Limited Warranty coverage periods for any Monsoon Engine that has been used for Commercial Purposes, while owned by the original purchaser, are as follows:

**Limited Warranty Summary:**

<b>Coverage Type</b>	<b>Coverage Period (from date of original retail purchase or initial use of the Monsoon Engine, whichever first occurs)</b>
----------------------	---

<b>Engine Limited Warranty</b>	<b>Earlier of twelve (12) months or 300 hours</b>
--------------------------------	---

The repair and/or replacement of components or parts under warranty does not extend the warranty period beyond the original expiration date.

**Section 6: Warranty Voiding Events**

The following events will automatically void and discharge Monsoon Engines from its obligations under this Limited Warranty and discharge Monsoon Engines from any obligations herein:

- the unauthorized disconnection, tampering with, or altering of Monsoon Engine’s hour meter;
- the unauthorized disabling of any warning device or system installed in any Cobalt Boat and/or Monsoon Engine;
- the unauthorized disconnection, disturbance or compromise of any wires, hoses, tubes, cables, looms or other components of the Cobalt Boat’s and/or Monsoon Engine’s electrical or fuel systems;
- the use of the Monsoon Engine installed in a Cobalt Boat in any criminal enterprise or to perform any criminal acts; and
- the determination by any state or federal entity or private insurance carrier that the Monsoon Engine is a total loss or fit only for salvage.

**Section 7: Other Matters Related to the Limited Warranty**

In addition to the Limited Warranty terms and exclusions noted above, the following are additional important considerations regarding the Limited Warranty:

**Section 7.1. Pre-Delivery**

Defects and/or damage to the finish surfaces on the Monsoon Engine may occur during production. These items are usually detected and corrected prior to shipment to the dealership or by the retail dealer prior to delivery to the retail customer. Nonetheless, consumers are encouraged to inspect the Monsoon Engine for this

type of damage prior to taking delivery, and all such defects or damage must be reported to the retail Cobalt Boat dealer at the time of delivery to have any items covered by this Limited Warranty addressed, and to have any covered defects repaired at no cost to the Purchaser.

**Section 7.2. Operation, Care and Maintenance**

To ensure the maximum benefit from ownership of this engine, Monsoon Engines requires that you follow all of the instructions in this Owner’s Manual, including all accompanying maintenance or service schedules and support material. Because questions may sometimes arise relating to the cause of a particular failure, Monsoon Engines strongly recommends keeping detailed records of any and all maintenance or service performed on the engine to assist, if necessary, in the determination of whether a failure is covered under this Limited Warranty. Damages to a Monsoon Engine caused by improper operation, care and maintenance are not covered by this Limited Warranty.

**Section 7.3. Design and/or Manufacturing Changes**

Monsoon Engines reserves the right to implement changes in the construction or components of any Monsoon Engine at any time, without incurring any obligation to make the same or similar changes on Monsoon Engines previously built and/or sold.

**Section 7.4. Other Warranties**

Some manufacturers of component parts included in a Monsoon Engine may provide limited warranties. Please refer to component part manufacturer’s limited warranty disclosures, if any, for details, including their terms, conditions, and limitations, of which Monsoon Engines makes no representations or warranties. Among other warranties, note that certain items are among those components covered by individual, separate warranties, which are explained and set forth in materials supplied by the component part manufacturer. Any and all claims or defects should be submitted directly to the manufacturers of those particular component parts.

**Section 7.5. No Other Warranties**

No oral or written information, advice, or communication of any nature by or from Cobalt Boats and/or Monsoon Engines or their representatives, employees, dealers, agents, distributors or suppliers shall create a warranty or in any manner increase or modify the scope of this Limited Warranty. The repair and/or replacement of components or parts under warranty does not extend the warranty period beyond the original expiration date.

## **Section 8: Customer Satisfaction Procedure**

### **Section 8.1. Warranty Claim Procedure**

To obtain warranty service and/or repairs, the following steps are required:

- (a) Notify a service facility or dealership authorized by Cobalt Boats/Monsoon Engines to perform service or repairs to Monsoon Engines ("Authorized Service Dealer") or Cobalt Boats/Monsoon Engines of the substantial defect in materials or workmanship attributable to Monsoon Engines, within thirty (30) days of discovery of the defect (which must be in the applicable Coverage Period);
- (b) Promptly schedule an appointment with and deliver the Monsoon Engine to an Authorized Service Facility for repairs. Warranty service must be performed by Cobalt Boats or an Authorized Service Dealer. For assistance in locating an Authorized Service Dealer, please call Cobalt Boats at (800) 468-5764.

*\* Monsoon Engines reserves the right to require further evaluation and/or information regarding a warranty claim against a Monsoon Engine prior to its repair as well as designate the place of repair.*

Subject to the terms of this Limited Warranty, any covered Monsoon Engine or component part with a substantial defect in materials or workmanship that is returned to an Authorized Service Dealer during the appropriate Limited Warranty period will be repaired or replaced, in Monsoon Engine's sole discretion, without charge to the Purchaser for parts and labor. This provision is subject to the following terms and conditions:

- (a) Monsoon Engines shall be obligated only to repair or replace those items that prove defective, in Monsoon Engines' sole discretion, upon examination by a qualified representative of an Authorized Service Dealer or by Monsoon Engines' own personnel, as applicable;
- (b) Monsoon Engines warrants authorized repairs or replacements made by or on behalf of Monsoon Engines only for the remainder of the applicable Coverage Period;
- (c) The Purchaser shall be responsible for all costs associated with the transportation of the Cobalt Boat with the applicable Monsoon Engine, towing bills, trailer, or component part(s) to Cobalt Boats' facility and/or to the Authorized Service Dealer, as well as for any return transportation.

Note that Authorized Service Dealers, generally, are independently owned and operated businesses. Monsoon Engines does not control the scheduling of service work. However, if you encounter any material delays in obtaining service at one of Cobalt Boats' Authorized Service Dealers, please call Cobalt Boats for assistance at (800) 468-5764.

## **Section 8.2. Direct Contact Information for Warranty Issues**

Cobalt Boats  
1715 North 8th Street  
Neodesha, Kansas 66757  
(800) 468-5764

### **Section 8.3. Procedure Regarding Concerns with Covered Warranty Repairs**

Concerns related to a Monsoon Engine can normally be addressed by an Authorized Service Dealer. If concerns are not satisfied, the following steps should be followed:

- (a) Ask to discuss concerns with a member of the Authorized Service Dealer's management. Ordinarily this will be the Authorized Service Dealer's service manager or service foreman. If resolution of the issue is not achieved, request to speak with the Authorized Service Dealer's general manager or owner.
- (b) If concerns are not resolved by the representatives of the Authorized Service Dealer, contact Cobalt Boats' Customer Service Department at the address noted above. Be prepared to provide the customer service representative with your name, address and phone number, your boat's hull identification number, the Authorized Service Dealer(s) at which the boat has been serviced, and the nature of the concerns with the boat or the service. Cobalt Boats will thereafter provide assistance to the boat owner and the Authorized Service Dealer, as necessary, to attempt to resolve the matter.

### **Section 8.4. Dispute Resolution**

**EXCEPT TO THE EXTENT PROHIBITED BY ANY APPLICABLE STATE OR FEDERAL LAW, PRIOR TO INITIATING ANY LEGAL ACTION AGAINST MALIBU BOATS, (1) YOU ARE REQUIRED TO PROVIDE MALIBU BOATS WRITTEN NOTICE, AT THE ADDRESS ABOVE, OF ANY SUBSTANTIAL DEFECT IN MATERIALS OR WORKMANSHIP THAT REMAINS UNRESOLVED TO YOUR SATISFACTION UNDER THE TERMS OF THE LIMITED WARRANTY; AND (2) TO THE EXTENT PERMITTED BY ANY STATE OR FEDERAL LAW, YOU MUST FIRST USE AN AVAILABLE DISPUTE SETTLEMENT MECHANISM OR ARBITRATION.**

## **Section 9: Warranty Transfer**

Upon the first sale of a Monsoon Engine that has not been utilized for any Commercial Purpose by the original, non-commercial, retail purchaser, within the first sixty (60) months, beginning on the date of the original retail purchase or the initial use of the Monsoon Engine, whichever occurs first, any unexpired Limited Warranty coverage can be transferred to a second, non-commercial

cial, owner and remain in effect for the unexpired period. The Limited Warranty on all other components is as previously identified within this Limited Warranty Statement. This provision is pursuant to the requirements set forth in the Warranty Transfer information provided within this Owner's Manual. Only one transfer of the Limited Warranty within the applicable time period(s) established will be honored. All coverage under the Limited Warranty Statement will become null and void in totality with any subsequent conveyance of ownership of the Monsoon Engine or transfer of the Monsoon Engine's title to any third party.

The Monsoon Engine must be fully inspected by an authorized Cobalt Boats dealer. The dealer will complete a warranty transfer specific to that engine. The transfer must be signed by the second private owner. The transfer forms are available through the dealership only.

Consumer payment must be made to the dealer directly in the amount of \$1,000.00. *Payment cannot be made directly to Cobalt Boats.* The dealer will complete the warranty transfer process on behalf of the seller and buyer.

## MALIBU TRAILERS LIMITED WARRANTY STATEMENT

### **Section 1: Certain Limitations and Disclaimer of Implied Warranties**

THE LIMITED WARRANTY SET FORTH HEREIN IS IN LIEU OF ALL OTHER WARRANTIES AND REPRESENTATIONS, EXPRESS OR IMPLIED, AND TO THE MAXIMUM EXTENT PERMITTED BY APPLICABLE LAW. MALIBU BOATS, LLC DISCLAIMS, AND THE PURCHASER HEREBY EXPRESSLY WAIVES, ANY AND ALL OTHER WARRANTIES OR REPRESENTATIONS OF ANY KIND OR NATURE, INCLUDING, BUT NOT LIMITED TO, IMPLIED WARRANTIES OF MERCHANTABILITY AND FITNESS FOR A PARTICULAR PURPOSE, OTHER THAN THOSE WARRANTIES WHICH ARE IMPLIED BY, AND ARE INCAPABLE OF EXCLUSION, RESTRICTION OR MODIFICATION UNDER APPLICABLE LAW. THERE ARE NO WARRANTIES WHICH EXTEND BEYOND THE DESCRIPTION OF THE FACE HEREOF. ANY IMPLIED WARRANTY THAT IS FOUND TO ARISE BY STATE OR FEDERAL LAW, INCLUDING ANY IMPLIED WARRANTY OF MERCHANTABILITY OR ANY IMPLIED WARRANTY OF FITNESS, IS LIMITED IN DURATION TO THE DURATION SET FORTH IN THIS LIMITED WARRANTY OR THE DURATION SET FORTH BY APPLICABLE STATE OR FEDERAL LAW, WHICHEVER IS SHORTER.

PERFORMANCE OF REPAIRS AND NEEDED ADJUSTMENTS IS THE EXCLUSIVE REMEDY UNDER THIS LIMITED WARRANTY, WITHOUT EXCLUSION, MODIFICATION OR RESTRICTION, OTHER THAN UNDER APPLICABLE LAW. MALIBU BOATS, LLC SHALL NOT BE LIABLE FOR INCIDENTAL OR CONSEQUENTIAL DAMAGES, SUCH AS, BUT NOT LIMITED TO, LOST WAGES, SLIP FEES, TRANSPORTATION TO OR FROM REPAIR, OR RENTAL EXPENSES, RESULTING FROM BREACH OF THIS WRITTEN WARRANTY OR ANY IMPLIED WARRANTY, OR OTHERWISE, EVEN IF MALIBU BOATS, LLC HAS BEEN ADVISED OF OR SHOULD HAVE FORESEEN THE POSSIBILITY OF SUCH DAMAGES, AND EVEN IF

ANY MALIBU BOAT OR COMPONENT PART THEREOF FAILS OF ITS ESSENTIAL PURPOSE. THIS EXCLUSIVE REMEDY SHALL NOT BE DEEMED TO HAVE FAILED OF ITS ESSENTIAL PURPOSE AS LONG AS MALIBU BOATS, LLC IS WILLING AND ABLE TO REPAIR OR REPLACE ANY DEFECTIVE GOODS SUBJECT TO THE TERMS PROVIDED HEREIN. UNDER ANY CIRCUMSTANCE, THE ENTIRE LIABILITY OF MALIBU BOATS, LLC IS LIMITED TO THE LESSER OF THE REPAIR OR REPLACEMENT OF ANY DEFECTIVE COMPONENT OR AFFECTED PORTION OF THE MALIBU TRAILER, OR THE ACTUAL PRICE PAID FOR THE MALIBU TRAILER.

SOME STATES DO NOT ALLOW LIMITATIONS ON TIME LIMITS OR EXCLUSIONS OF INCIDENTAL OR CONSEQUENTIAL DAMAGES, SO THE ABOVE LIMITATIONS MAY NOT APPLY TO YOU. THIS LIMITED WARRANTY GIVES YOU SPECIFIC LEGAL RIGHTS WHICH MAY VARY FROM STATE TO STATE, BY JURISDICTION, AND COUNTRY. TO THE EXTENT THAT YOUR STATE DOES NOT ALLOW ANY EXCLUSION OR LIMITATION EXPRESSED HEREIN, SUCH EXCLUSION OR LIMITATION WILL NOT APPLY TO YOU. ALL OTHER ALLOWABLE LIMITATIONS OR EXCLUSIONS SHALL APPLY TO YOU.

### **Section 2. The Limited Warranty Application and Terms; Transferability**

Malibu Boats, LLC ("Malibu Boats"), warrants to the original user or purchaser, whoever comes first (hereafter the "Purchaser"), that each new and unused Malibu trailer ("Malibu Trailer"), shall under normal authorized use remain free from defects in craftsmanship and materials during the applicable warranty periods, in accordance with and subject to the terms, conditions and limitations as described in this Limited Warranty. Any and all references to Malibu Trailers within this document refer to

only those complete trailers or trailer component, which are manufactured by Malibu Boats. Trailers manufactured by outside suppliers are covered under, and subject to, limitations and time duration as described within the limited warranty statements provided by the supplier.

Subject to all other terms, conditions, and limitations, 1) original Purchaser(s) of the Malibu Trailer and, 2) second owners of the Malibu Trailer who purchase the trailer within sixty (60) months or 500 hours [and twelve (12) months for the trailer paint], of the earlier of (a) the date the trailer was purchased by the first retail purchaser through an authorized Cobalt Boats Sales facility, or (b) the date the trailer was first put into service as a demonstrator or other use except for commercial purpose (from which there is no transferability of the limited warranty), and qualify for and complete a warranty transfer as explained below, are provided coverage under the Malibu Trailers Limited Warranty.

**Note: This Limited Warranty is expressly conditioned upon the timely completion and return of the warranty registration card to Cobalt Boats. Although not obligated to and without creating such an obligation, this will enable Cobalt Boats to notify you of any necessary performance or safety modifications to your Malibu Trailer and to verify ownership in case a warranty claim is filed on your Malibu Trailer.**

The Limited Warranty is expressly subject to the following terms, conditions, and limitations. All warranty applications are dependent upon the Purchaser following the guidelines established for appropriate and reasonable care and maintenance of the Malibu Trailer, and operating his or her Malibu Trailer reasonably and as directed in this Owner's Manual, and as directed in any additional directions and/or owner's manuals relating to any specific component part or parts of the Malibu Trailer (the "Guidelines and Directions"). **Purchaser's failure to follow such Guidelines and Directions shall void this Limited Warranty.**

All repairs performed by Cobalt Boats, or its authorized service facilities, will be performed using either new or re-manufactured parts. Cobalt Boats and/or Malibu Trailers may, at their option, install parts which have substantially similar or greater performance characteristics if an identical replacement part is no longer available.

No person or entity is authorized to make any additional or revised statement or warranty, express or implied, on behalf of Malibu Trailers or any component supplier beyond what appears within this Limited Warranty.

### Limited Warranty Summary:

Coverage Type	Coverage Period (from date of original retail purchase or initial use of the Malibu Trailer, whichever first occurs)
---------------	--

**Trailer Limited Warranty Sixty (60) Months**

**Trailer Paint Limited Warranty Twelve (12) Months**

The repair and/or replacement of components or parts under warranty does not extend the warranty period beyond the original expiration date.

#### Section 2.1 Trailer Limited Warranty

For a period of sixty (60) months beginning on the date of the original retail purchase or the initial use of the Malibu Trailer, whichever occurs first, Malibu Trailers will repair or replace materials or workmanship supplied by it during construction of the Malibu Trailer, including parts and labor, which are determined by Malibu Trailers to contain substantial manufacturing defects.

This Limited Warranty does not provide coverage for any component part that is at any time covered by any warranty provided by any third party, other than Malibu Trailers, including, but not limited to the manufacturer of the component part. Component parts shall include, but are not necessarily limited to, any items that are fastened to the trailer through either mechanical means (screws/bolts) or chemical means (adhesives), which may or not be manufactured by Malibu Trailers. Some examples of component parts include brake actuator, brakes, axles, lights, etc. In the event that any warranty coverage for any component part is rendered or deemed void due to actions of the Purchaser or any third party other than Malibu Trailers, this Limited Warranty will not provide warranty coverage for the component part.

#### Section 2.2. Trailer Paint Limited Warranty

*Note: Trailer paint maintenance is the Purchaser's responsibility.* Conditioned on the Purchaser having provided and performed all trailer paint maintenance and care described in this Owner's Manual, for a period of twelve (12) months, beginning on the date of the original retail purchase or the initial use of the Malibu Trailer, whichever occurs first, Malibu Trailers will repair materials, or workmanship supplied by it, in applying the paint finish to the trailer, which are determined by Malibu Trailers to contain substantial manufacturing defects. This Trailer Paint Limited Warranty shall not include or provide coverage for scratches and other damage caused by trailering, including normal usage.

### **Section 3: Limited Warranty Exclusions and Limitations**

In addition to any prior limitations and exclusions, the following are **NOT** covered under this Limited Warranty:

- normal maintenance of the Malibu Trailer or any component thereof;
- normal wear-and-tear of the Malibu Trailer or any component thereof;
- damages or needed adjustments caused by items that are added, altered or changed after the Malibu Trailer leaves the possession of Cobalt Boats;
- modification, alteration, unauthorized repair or replacement of components, including but not limited to damages resulting from such installations, on the Malibu Trailer;
- damages caused by accident (including impacts and collisions with any object), abuse, misuse, neglect, negligence, mishandling or alteration, including any damages caused by or during trailering or towing;
- damages caused by heat, fire, explosion or freezing;
- damages caused by atmospheric fallout, chemical treatments, tree sap, salt, ocean spray, mold, or animal droppings, lightning, hail, rain, flooding, wind, sand, floods or other environmental or natural conditions or Acts of God;
- damages caused by vandalism or theft;
- failure to follow the instructions within this Owner's Manual regarding corrosion prevention and operation in salt or brackish water may result in or contribute to these types of damage and are not covered under the Limited Warranty;
- damages caused by aftermarket cleaning products or additives not specifically approved by Malibu Trailers;
- damages due to insufficient or improper maintenance, lack of maintenance, or delay of repair (unless specifically and directly authorized by Cobalt Boats warranty department in writing);
- damage or contamination resulting from leaking or spilled fluids including, but not limited to, fuel or drive train fluids;
- conditions resulting from use of the trailer for anything other than recreational purposes (Note: Commercial use as described in this owner's manual will affect the length of warranty coverage. Please refer to *Section 5: Commercial Use Exclusions / Restrictions* for specific details);
- manufacturing variations or imperfections in cosmetic, convenience or aesthetic components or features of the trailer which have no effect on use or safety;
- damages caused by improper weight distribution or excessive weight combinations of persons aboard, ballast or simulated ballast and gear left onboard during trailering;
- any material, component or part of the boat that has a warranty period and/or conditions as specified by

the producing entity which differs from this Limited Warranty unless such warranties are administered directly by the producing entity;

- damages caused by water intrusion into any component of the trailer;
- any and all consequential damages including, but not limited to, costs incurred for haul-out, launching, towing, storage charges, telephone, expedited shipping of replacement parts, or rental charges of any type (including slip fees), inconveniences, or loss of time or income;
- damage or injury resulting from failure to comply with recall notices, service bulletins and advisories, or requests from Cobalt Boats and/or Malibu Trailers to repair the boat or its components;
- damage or injury resulting from speeding, demonstration or any type of racing;
- damages resulting from the failure to properly maintain and care for the trailer and its components in accordance with the instructions found within this Owner's Manual;
- shop supplies used in correction work, such as, but not limited to, sealants, lubricants, cleaning supplies;
- damage resulting from erroneous service by the customer or technician not authorized by Cobalt Boats and/or Malibu Trailers to perform service or corrections;
- damage that cannot be traced to material defects in materials or workmanship, as determined by Malibu Trailers.

### **Section 4: International Exclusions/ Requirements**

Importing or exporting any Malibu Trailer manufactured in the United States by Malibu Trailers ("US Malibu Trailer") into Australia or New Zealand immediately and completely voids any and all coverage provided under this Limited Warranty and any and all obligations owed by Malibu Trailers relative to the US Malibu Trailer. This Limited Warranty does not provide coverage to any Malibu Trailer purchased from a dealer in another country where the primary use of the Malibu Trailer will require the Malibu Trailer to cross an international border. The Limited Warranty will not be honored by Malibu Trailers for any Malibu Trailer that is acquired by the Purchaser through an international cross-border purchase. All repairs that are covered under this Limited Warranty must be performed in the country where the Malibu Trailer was originally purchased.

### **Section 5: Commercial Use Exclusions/ Restrictions**

The use of any Malibu Trailer for commercial purposes, including but not limited to as a demonstrator, or in con-



nection with any promotional program, ski, wakeboard, or surf school or show (“Commercial Purposes”) shall alter the Limited Warranty as set forth herein. The Limited Warranty applicable to any Malibu Trailer used for any Commercial Purpose may not be transferred to any subsequent owner of the Malibu Trailer. The Limited Warranty coverage periods for any Malibu Trailer that has been used for Commercial Purposes, while owned by the original purchaser, are as follows:

**Limited Warranty Summary:**

<b>Coverage Type</b>	<b>Coverage Period (from date of original retail purchase or initial use of the Malibu Trailer, whichever first occurs)</b>
----------------------	---

<b>Trailer Limited Warranty</b>	<b>Twelve (12) Months</b>
---------------------------------	---------------------------

The repair and/or replacement of components or parts under warranty does not extend the warranty period beyond the original expiration date.

**Section 6: Warranty Voiding Events**

The following events will automatically void and discharge Malibu Trailers from its obligations under this Limited Warranty and discharge Malibu Trailers from any obligations herein:

- the unauthorized disconnection, disturbance or compromise of any wires, hoses, tubes, cables, or other components of the Malibu Trailer’s systems;
- the use of the Malibu Trailer in any criminal enterprise or to perform any criminal acts; and
- the determination by any state or federal entity or private insurance carrier that the Malibu Trailer is a total loss or fit only for salvage.

**Section 7: Other Matters Related to the Limited Warranty**

In addition to the Limited Warranty terms and exclusions noted above, the following are additional important considerations regarding the Limited Warranty:

**Section 7.1. Pre-Delivery**

Defects and/or other observable cosmetic components of your Malibu Trailer may occur during production. These items are usually detected and corrected prior to shipment to the dealership or by the retail dealer prior to delivery to the retail customer. Nonetheless, consumers are encouraged to inspect the Malibu Trailer for this type of damage prior to taking delivery, and all such defects or damage must be reported to the retail Cobalt Boat dealer at the time of delivery to have any items covered

by this Limited Warranty addressed, and to have any covered defects repaired at no cost to the Purchaser.

**Section 7.2. Boat Operation, Care and Maintenance**

To ensure the maximum benefit from ownership of this boat, Malibu Trailers requires that you follow all of the instructions in this Owner’s Manual, including all accompanying maintenance or service schedules and support material. Because questions may sometimes arise relating to the cause of a particular failure, Malibu Trailers strongly recommends keeping detailed records of any and all maintenance or service performed on the trailer to assist, if necessary, in the determination of whether a failure is covered under this Limited Warranty. Damages to a Malibu Trailer caused by improper operation, care and maintenance are not covered by this Limited Warranty.

**Section 7.3. Design and/or Manufacturing Changes**

Malibu Trailers reserves the right to implement changes in the construction or components of any Malibu Trailer at any time, without incurring any obligation to make the same or similar changes on Malibu Trailers previously built and/or sold.

**Section 7.4. Other Warranties**

Some manufacturers of component parts included in a Malibu Trailer may provide limited warranties. Please refer to component part manufacturer’s limited warranty disclosures, if any, for details, including their terms, conditions, and limitations, of which Malibu Trailers makes no representations or warranties. Among other warranties, note that certain items are among those components covered by individual, separate warranties, which are explained and set forth in materials supplied by the component part manufacturer. Any and all claims or defects should be submitted directly to the manufacturers of those particular component parts.

**Section 7.5. No Other Warranties**

No oral or written information, advice, or communication of any nature by or from Cobalt Boats and/or Malibu Trailers or their representatives, employees, dealers, agents, distributors or suppliers shall create a warranty or in any manner increase or modify the scope of this Limited Warranty. The repair and/or replacement of components or parts under warranty does not extend the warranty period beyond the original expiration date.

**Section 8: Customer Satisfaction Procedure**

**Section 8.1. Warranty Claim Procedure**

To obtain warranty service and/or repairs, the following steps are required:

- (a) Notify a service facility or dealership authorized by Cobalt Boats/Malibu Trailers to perform service or repairs to Malibu Trailers (“Authorized Service Dealer”) or Cobalt Boats/Malibu Trailers of the substantial defect in materials or workmanship attributable to Malibu Trailers, within thirty (30) days of discovery of the defect (which must be in the applicable Coverage Period);
- (b) Promptly schedule an appointment with and deliver the Malibu Trailer to an Authorized Service Facility for repairs. Warranty service must be performed by Cobalt Boats or an Authorized Service Dealer. For assistance in locating an Authorized Service Dealer, please call Cobalt Boats at (800)468-5764.

*\* Malibu Trailers reserves the right to require further evaluation and/or information regarding a warranty claim against a Malibu Trailer prior to its repair as well as designate the place of repair.*

Subject to the terms of this Limited Warranty, any covered Malibu Trailer or component part with a substantial defect in materials or workmanship that is returned to an Authorized Service Dealer during the appropriate Limited Warranty period will be repaired or replaced, in Malibu Trailers’ sole discretion, without charge to the Purchaser for parts and labor. This provision is subject to the following terms and conditions:

- (a) Malibu Trailers shall be obligated only to repair or replace those items that prove defective, in Malibu Trailers’ sole discretion, upon examination by a qualified representative of an Authorized Service Dealer or by Malibu Trailers’ own personnel, as applicable;
- (b) Malibu Trailers warrants authorized repairs or replacements made by or on behalf of Malibu Trailers only for the remainder of the applicable Coverage Period;
- (c) The Purchaser shall be responsible for all costs associated with the transportation of the Malibu Trailer, towing bills, trailer, or component part(s) to Cobalt Boats’ facility and/or to the Authorized Service Dealer, as well as for any return transportation.

Note that Authorized Service Dealers, generally, are independently owned and operated businesses. Malibu Trailers does not control the scheduling of service work. However, if you encounter any material delays in obtaining service at one of Cobalt Boats’ Authorized Service Dealers, please call Cobalt Boats for assistance at (800) 468-5764.

**Section 8.2. Direct Contact Information for Warranty Issues**

Cobalt Boats  
 1715 North 8th Street  
 Neodesha, Kansas 66757  
 (800) 468-5764

**Section 8.3. Procedure Regarding Concerns with Covered Warranty Repairs**

Concerns related to a Malibu Trailer can normally be addressed by an Authorized Service Dealer. If concerns are not satisfied, the following steps should be followed:

- (a) Ask to discuss concerns with a member of the Authorized Service Dealer’s management. Ordinarily this will be the Authorized Service Dealer’s service manager or service foreman. If resolution of the issue is not achieved, request to speak with the Authorized Service Dealer’s general manager or owner.
- (b) If concerns are not resolved by the representatives of the Authorized Service Dealer, contact Cobalt Boats’ Customer Service Department at the address noted above. Be prepared to provide the customer service representative with your name, address and phone number, your boat’s hull identification number, the Authorized Service Dealer(s) at which the boat has been serviced, and the nature of the concerns with the boat or the service. Malibu Boats will thereafter provide assistance to the boat owner and the Authorized Service Dealer, as necessary, to attempt to resolve the matter.

**Section 8.4. Dispute Resolution**  
**EXCEPT TO THE EXTENT PROHIBITED BY ANY APPLICABLE STATE OR FEDERAL LAW, PRIOR TO INITIATING ANY LEGAL ACTION AGAINST MALIBU BOATS, (1) YOU ARE REQUIRED TO PROVIDE MALIBU BOATS WRITTEN NOTICE, AT THE ADDRESS ABOVE, OF ANY SUBSTANTIAL DEFECT IN MATERIALS OR WORKMANSHIP THAT REMAINS UNRESOLVED TO YOUR SATISFACTION UNDER THE TERMS OF THE LIMITED WARRANTY; AND (2) TO THE EXTENT PERMITTED BY ANY STATE OR FEDERAL LAW, YOU MUST FIRST USE AN AVAILABLE DISPUTE SETTLEMENT MECHANISM OR ARBITRATION.**

**Section 9: Warranty Transfer**

Upon the first sale of a Malibu Trailer that has not been utilized for any Commercial Purpose by the original, non-commercial, retail purchaser, within the first sixty (60) months, beginning on the date of the original retail purchase or the initial use of the Malibu Trailer, whichever occurs first, any unexpired Limited Warranty coverage



can be transferred to a second, non-commercial, owner and remain in effect for the unexpired period (Trailer Paint Limited Warranty, which is twelve [12] months. The Limited Warranty on all other components is as previously identified within this Limited Warranty Statement. This provision is pursuant to the requirements set forth in the Warranty Transfer information provided within this Owner's Manual. Only one transfer of the Limited Warranty within the applicable time period(s) established will be honored. All coverage under the Limited Warranty Statement will become null and void in totality with any subsequent conveyance of ownership of the Malibu Trailer or transfer of the Malibu Trailer's title to any third party.

The Malibu Trailer must be fully inspected by an authorized Cobalt Boats dealer. The dealer will complete a warranty transfer specific to that trailer. The transfer must be signed by the second private owner. The transfer forms are available through the dealership only.

Consumer payment must be made to the dealer directly in the amount of \$1,000.00. Payment cannot be made directly to Cobalt Boats or Malibu Trailers. The dealer will complete the warranty transfer process on behalf of the seller and buyer.





# Engine Option

# MONSOON ENGINES FOR COBALT BOATS

If your new Cobalt boat has a Monsoon engine installed, please note that it has been constructed to meet or exceed all U.S. Coast Guard and National Marine Manufacturers Association requirements at the time of its manufacture.

Prior to operating the boat for the first time, you must read and familiarize yourself with all the material in this owner's manual. **Note that this chapter covers only a Monsoon engine.** If your boat is equipped with another brand of engine, there will be a separate engine and/or propulsion manual provided by the manufacturer. You must follow the instructions in that manual(s) rather than this chapter.

All information within this chapter is accurate at the time of print; however, specifications and requirements are subject to change at any time. Always use caution and common sense when operating and maintaining your engine and boat.

## CAUTION

Cobalt boats can be equipped with a variety of drive train options, some built by manufacturing partners. The boat will ship with a separate engine owner's manual in those instances. All engine care and maintenance requirements should be followed in that manual. Failure to do so may void the warranty.

If your boat is equipped with a Monsoon® Engine, it was produced in-house as a division of Malibu Boats LLC (referred to in this manual as "Monsoon Engines").

Boats equipped with a Monsoon Engine also require proper care and maintenance attention to adhere to

warranty policy. Note that these instructions should be followed even after the warranty period has expired. The instructions developed for Monsoon Engines function as the guidelines to a long-term, positive boating experience.

## CAUTION

Failure to follow engine operation, care and maintenance instructions as provided in this manual can result in damage to the engine that is not covered under warranty. Under some circumstances, this could result in the boat becoming inoperable, stranding boaters and/or placing those on board in situations that could result in potential danger.

## CAUTION

Owners/operators must follow the instructions and must pay particular attention to the Saltwater Care and Maintenance instructions. Using the flush kit is essential to ensuring a long life for the Monsoon engine. Failure to follow those instructions can void the warranty, as well as adversely affect the operation of the engine and power train.

Monsoon Engines has teamed with General Motors to produce the ideal engine for the expected usage of the boat. Because the Monsoon line of engines were created to further enjoyment of watersports, the power curve and maximum performance of the packages were designed to enhance every aspect of the experience.

**THE FOLLOWING INFORMATION IS PROVIDED FOR THE MONSOON LINE OF ENGINES. UNLESS OTHERWISE DIRECTED, THE INSTRUCTIONS ARE APPLICABLE TO ALL MONSOON ENGINE MODELS AVAILABLE ON COBALT BOATS.**

## SAFETY

Significant safety information appears within this owner's manual. **It is critical to read the entire manual, with particular attention to the safety information.** All boat owners and operators must adhere to the safety requirements as described. It is also the responsibility of these individuals to be aware of U.S. Coast Guard regulations when boating in U.S. waterways, or the governing body(ies) of any waterway system in which the boat is operated.

**Failure to read and follow this information will NOT exempt or excuse boaters from the requirements.** This information also materially impacts the boat and engine warranty coverage. It is the owner's and/or operator's responsibility to perform all inspections and required maintenance prior to the

operation of the boat, **without exception.**

In addition to the boat owner's manual, the following engine-specific, safety-related material is provided. Please review and follow these guidelines to ensure the safety of yourself, boat operators, passengers and others who may be in the area.



### Prior to Operation

## DANGER

**To prevent a possible explosion, in boats equipped with an automatic blower system, always operate the blower**

until it automatically shuts off. For boats not equipped with an automatic blower system, operate the blower for at least four (4) minutes, prior to starting the engine. Improper ventilation can lead to accumulation of gasoline or exhaust fumes in the compartment. This can lead to a fire or explosion, either of which can result in serious injury or death!

**! DANGER**

Never start the engine in the presence of fumes or signs of gasoline leakage. Always avoid smoking or open flame near the engine compartment.

## Other Safety Double Checks

Throughout this section of the owner's manual, additional safety issues are reiterated. Always follow these instructions. Repeating checks and inspections is far superior to ever skipping any of these requirements and suggestions.

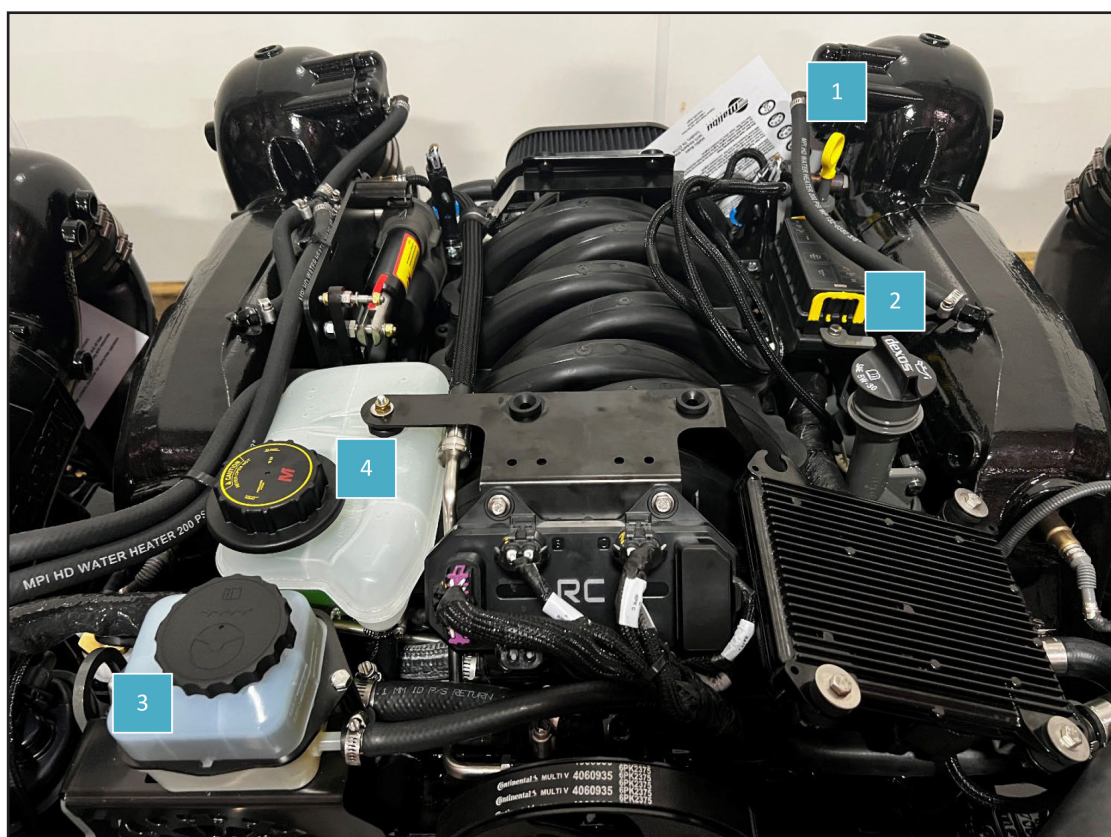

General overhead view of engine showing various components, such as the 1) oil dipstick; 2) oil fill; 3) power steering fluid reservoir, and 4) coolant reservoir.

## GENERAL INFORMATION

### Serial Numbers

Each engine is assigned a unique serial number that is different from the Hull Identification Number (HIN) found on the transom of the boat. The engine serial number can be found in two locations on the engine: the bank one engine lifting eye, and the front of the oil pan.

It is extremely rare that an engine requires replacement in a boat; however, if this occurs, **the replacement**

**engine's serial number must be reported to the Monsoon Engines warranty department, even if the warranty statement effective dates have expired.** In the event of a safety matter or recall, serial numbers often alert the factory to which boats may be affected and allow the company to contact consumers.

Engine serial numbers that do not match factory records may lead to questions of legality also.

## Engine Specifications

Engine Descriptor	M5Di	M6Di
Type/Aspiration	4 Cycle – Naturally Aspirated	4 Cycle – Naturally Aspirated
Engine Configuration	90-degree V8	90-degree V8
Displacement (cc)	5,300cc (327 CID)	6,200cc (383 CID)
Borespacing (mm)	111.76	111.76
Bore x Stroke (mm)	96.01 X 92	103.25 X 92
Compression Ratio	11:1	11:1
Fuel Compatibility	Gasoline	Gasoline
Engine Rotation (Front)	CW	CW
Block / Head Material	Cast Aluminum	Cast Aluminum
Block Structure	Deep Skirt	Deep Skirt
Main Bearing Caps	6 Bolt	6 Bolt
Valvetrain Configuration	OHV-CIB	OHV-CIB
Valves per Cylinder	2V	2V
Valve Lifter / Lash Adjuster	Roller Hydraulic	Roller Hydraulic
CAM Drive	3/8" Roller Chain	3/8" Roller Chain
Firing Order	1-8-7-2-6-5-4-3	1-8-7-2-6-5-4-3



### Engine Coolant

All Monsoon Engines feature a hybrid of raw water cooling and closed cooling. **The closed cooling must have a 50/50 mix of marine-grade, propylene glycol coolant (such as Peak Sierra brand) and clean, distilled water. DO NOT USE ANY EHTYLENE-BASED PRODUCTS.**

From an empty engine (no coolant in engine or expansion tank) to the proper amount of coolant/water mix will require approximately 2.5 gallons. If equipped with a heater option, additional coolant will be required.

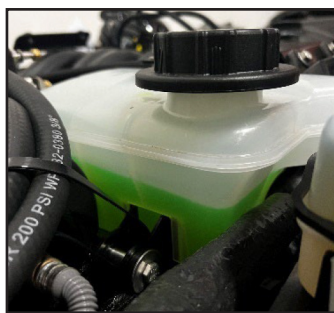

Directions for maintaining proper levels are provided in the *Care and Maintenance* chapter. Maintaining proper levels is required to keep the warranty in effect, and the instructions should continue to be followed for the life of the boat/engine. Boat owners should also carefully follow the raw water cleaning information provided in the *Care and Maintenance* section, especially when operating in salt water or brackish water conditions. Failure to do so will void the warranty. Also see the

*Salt Water* information provided in the *Care and Maintenance* chapter.



### Engine Oil

In M-Series engines (M5—5.3 liter engine and M6—6.2 liter engine), use on 5W30 full synthetic dexos™Gen2 Engine Oil. Use **ONLY Mobil 1**, per General Motors specifications. The use of any other oils or



fluids are not approved and may void the warranty.

The engine requires approximately nine (9) quarts to fill from empty. (Never overfill the engine oil, nor run the engine without sufficient oil as indicated on the oil dipstick.)



**Be sure to check the engine oil level before each use.**



## Power Steering

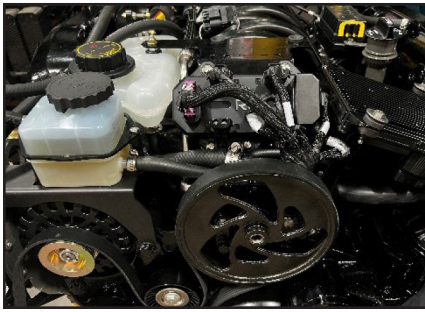

The Monsoon Engine may be equipped with a power steering pump that works in conjunction with the boat manufacturer's steering system and/or the Mercury outdrive. If the power steering option was selected, the fluid levels will need to be checked at a regular interval. The reservoir tank on the top of the engine has a removable cap that has a fluid level indicator (also known as a dipstick) underneath. Verify the fluid level is at the **FULL** mark as indicated on the fluid level indicator.

### CAUTION

**Be sure to check the power steering fluid level before each use.**

Steering cables are another important component of the Mercury Marine engine-assisted steering system in your boat. Maintenance of these steering cables—especially lubrication—is vital to ensuring the longevity of your boat's steering system. Please refer to the instructions below provided by Mercury Marine for the proper lubrication of the steering cables.



## Serpentine Belt

Inspect your Monsoon Engine's serpentine belt at every oil change interval, i.e., every 50 hours of operation. If the serpentine belt shows signs of abnormal wear, immediately have it replaced by an authorized dealer technician. In addition to this regular inspection, you must also be sure to replace the serpentine belt at every 300 hours of operation. Refer to the *Maintenance Schedule* included in the *Care and Maintenance* information provided later in this section of the owner's manual for an overview of service intervals.

## Fuel Filter



Monsoon Engines are equipped with a Smart Fuel Filter that separates water from the boat's fuel, and it alerts the operator—via the dash—when an unacceptable level of water is detected in the fuel system. **DO NOT** ignore such alerts from the Smart Fuel Filter, as continued operation of the boat with water in the fuel system can lead to engine damage and/or failure.

### DANGER

**Boat owners or any person who is not an authorized dealer technician should never attempt to work on the fuel systems within the boat. These systems require specialized tools not available to the public. Any alteration to or attempt to alter these systems will void the warranty. It is also highly likely that serious injury or death could occur to unauthorized persons attempting to access these systems.**



## Mercury Marine Outdrive

A Monsoon Engine is paired with a Mercury Marine outdrive system. Please consult your Mercury Marine Outdrive's warranty information as the outdrive has a specific break-in procedure in addition to that of the engine.

Shown below is a summary of Mercury Marine's recommended outdrive break-in cycle. However, if you have a separate outdrive-specific owner's manual provided by Mercury Marine, the outdrive break-in procedure instructions provided therein supersede the outdrive break-in instructions provided in this owner's manual.

Again, consult your Mercury Marine outdrive warranty information as the current recommendation from Mercury is that the outdrive gear lube be changed at 20 hours of operation, then again at 100 hours of operation. After the first 100-hour gear lube change is complete, it is recommended the gear lube be changed every 100 hours going forward.

Recommended Mercury Marine Outdrive Break-In Procedure		
IMPORTANT: Perform all steps while underway.		
ENGINE SPEED (RPM)	TIME (MINUTES)	INSTRUCTIONS
IDLE	5	SHIFT 5 TIMES (F-N-R-N-F)
2000	15	
IDLE	1	SHIFT 5 TIMES (F-N-R-N-F)
3000	15	
IDLE	1	SHIFT 5 TIMES (F-N-R-N-F)
4000	15	
IDLE	1	SHIFT 5 TIMES (F-N-R-N-F)

# Lubrication of the Steering System

**⚠ WARNING**

Incorrect cable lubrication can cause hydraulic lock, leading to serious injury or death from loss of boat control. Completely retract the end of the steering cable before applying lubricant.

*NOTE: If the steering cable does not have a grease fitting, the inner wire of the cable cannot be greased.*

1. If the steering cable has grease fittings, turn the steering wheel until the steering cable is fully retracted into the cable housing. Apply approximately three pumps of grease from a typical hand-operated grease gun.

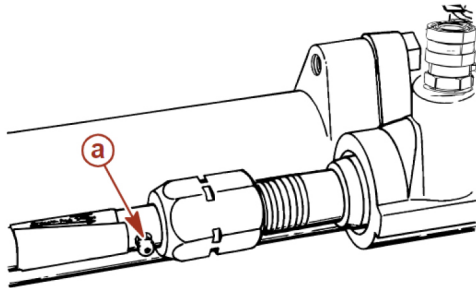

a - Steering cable grease fitting

Description	Where Used	Part No.
2-4-C with PTFE	Steering cable grease fitting	92-802859A 1

2. Turn the steering wheel until the steering cable is fully extended. Lightly lubricate the exposed part of the cable.

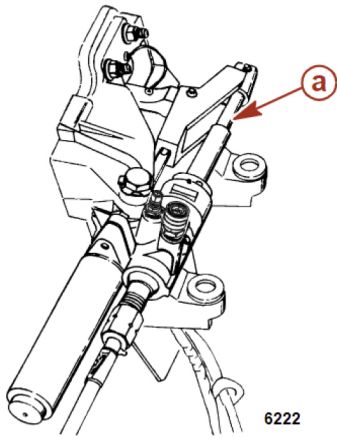

a - Extended steering cable

Description	Where Used	Part No.
2-4-C with PTFE	Steering cable	92-802859A 1

3. Lubricate the steering pin.

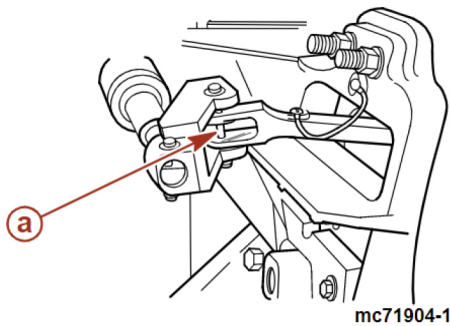

a - Steering pin

Description	Where Used	Part No.
Mercury 25W-40 Synthetic Blend 4-Stroke Engine Oil	Steering pin	92-8M0078629

# CALIFORNIA EMISSIONS INFORMATION

Monsoon Engines works with the state of California to ensure that emissions from our products remain in compliance with California's legal requirements. This means attention to aspects of the warranty statement and process, with particular attention to providing this

information in clear, written style. Within the *Warranty* section of this owner's manual, specific detail on California Emissions requirements is included. If you have any questions regarding this matter, contact your authorized dealer.

## MONSOON ENGINE SUPPORT SYSTEMS

### Monsoon Fuel System

The Monsoon Engine is equipped with an engine-mounted fuel pump, which means the engine fuel system is under high pressure. Under normal operation the fuel lines will have a significant pounds-per-square-inch (PSI) pressure. As such, no one can or should ever attempt to access any portion of the fuel system without proper training and proper equipment. The prefera-



ble method is to have an authorized Cobalt dealer's trained service technician do so and verify that no damage has been done to the fuel pump, lines or other equipment.

The fuel system from tank-to-plumbing-to-engine meets or exceeds U.S. Coast Guard requirements (Sec. 183.540 *Recreational Boating*). Because of the potential for a dangerous, even catastrophic event if any part of the system fails, Monsoon Engines strongly encourages all owners/operators

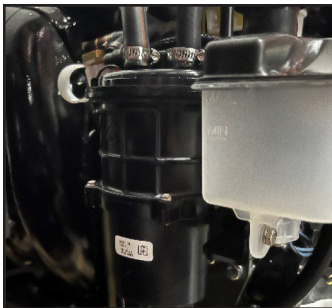

always be aware of proper operation. Follow operational directives, maintenance requirements and remain alert for visual signs or odors that indicate the presence of fuel outside the contained fuel system. Never replace any part of the fuel system except with approved parts, and Monsoon Engines recommends always using your authorized Cobalt dealer for checks, service and repair of the fuel system.

Normally, if there is any issue arising from damage or leakage in the fuel system, a strong odor of gasoline will be present and signifies that the engine should not be started due to the danger of explosion from fumes. Even in the absence of a gasoline odor, owners and operators should always visually check the fuel system prior to operation.

#### DANGER

**The fuel system, including the fuel lines and fuel pump, should never be serviced by any person other than an authorized Cobalt dealer's trained service technician. Special tools and training are required to safely service the fuel system on all models.**

#### DANGER

**The flammability of gasoline and its explosive properties must always be respected. At the first odor of gasoline, the engine should be shut off and remain off until the source of the odor has been identified, and the issue has been rectified. Never start the engine if the odor of gasoline is present or if gasoline is seen anywhere in the boat other than the fuel system!**

#### DANGER

**Never smoke or operate any spark-producing object within a fifty-foot (50') range of the boat when fueling. Fumes from gasoline are more likely to produce an explosion and/or fire than the actual fuel. Be sure that the fueling area is well-ventilated.**

#### DANGER

**If fuel is spilled, always clean up with dry rags and dispose properly on-shore.**

#### DANGER

**Replacement parts in any portion of the fuel system must be with Monsoon Engines-authorized parts only! Use of unapproved parts could result in a failure that creates a potentially explosive situation or the potential for on board fire.**

#### WARNING

**Avoid inhaling or ingesting gasoline and/or fumes. If gasoline gets on skin, immediately flush with copious amounts of fresh water on-shore; if gasoline gets on clothing, immediately change clothing and do not store gasoline-infused cloth on board the boat.**

Monsoon Engines recommends returning to shore and refueling whenever the fuel gauge indicates that the fuel load has fallen below one-quarter (1/4) of a full tank. **It has also been determined that continuous operation with ballast significantly loaded either port or starboard (rather than evenly distributed) can result in damage to the fuel pump as it attempts to compensate.** Even with the best of care, some water may get into the fuel tank or separate from the fuel that is pumped into it. If there is water present, it will settle on the bottom of the tank. If the pump begins to reach any water, it may cause malfunctioning in the engine.

### CAUTION

**Do not overfill the fuel tank. Doing so can cause spillage, which is an environmental hazard. Fuel tanks also expand and contract slightly to adjust to ambient air temperature.**

### NOTICE

**Use of incorrect fuel can result in damage to the engine that is not covered by Monsoon Engine's Limited Warranty. Failure to follow maintenance requirements may also void the warranties.**



## Fuel Information

**The minimum octane requirement for M-Series engines is 87 (R+M)/2 or 92 Euro RON. When possible, use 93 octane, if available, as this will ensure the best performance possible from the engine. (Boaters outside the U.S. and Canada should confer with their authorized dealer to determine the correct fuel grading, as it is often graded differently from how it was designated in the U.S. and Canada, which is described herein.)**

**Lower-octane fuel may cause deposits on the fuel injectors and intake valves, among engine components. Continued over a period of time, the lower-octane fuel could damage the engine, and such damage is not covered under warranty.**

One of the first signs of improper fueling is a knocking noise resulting from spark plug misfire. Knock misfire will damage the engine over time. Because the engine is equipped with a knock sensor, operators may be alerted when the sensor triggers a warning. **Do not ignore such warning!**

The engines are designed to run smoothly. If there are any symptoms of misfire, hesitation, poor idling or if the engine becomes hard to start, such indications should not be ignored. If the gasoline has been in the boat's tank for an extended period (in excess of two weeks), particularly without a stabilizer, the issue sometimes may be addressed by properly replacing the fuel with new gasoline.

### DANGER

**Always dispose of unused fuel properly on-shore. Check with local authorities to determine the proper manner in which fuel can be off-loaded from a boat. NEVER dump fuel into the water. It is illegal to do so as well as environmentally damaging. Allowing fumes to be vented can also cause a situation in which a spark or open flame could cause a fire, which is extremely dangerous and could result in serious injury or death.**

**Never add diesel fuel to the fuel tank!** Diesel fuel and regular gasoline do not mix. Diesel fuel will cause permanent damage to the engine, and such damage is not covered under warranty. If diesel fuel is accidentally pumped into the fuel system, all contents of the fuel tank must be properly disposed of on-shore, and the engine should not be started until the system is thoroughly cleared and the correct fuel pumped into the fuel tank.



## When Fueling

**When pumping fuel, do not leave the nozzle unattended in the fuel fill.** Although the fuel system has been manufactured to avoid spit-back of fuel, and most gasoline dispensers will shut off if removed from the fuel fill, it is always a wise consideration to provide full attention to the process.

Monsoon Engines strongly recommends using 93 octane TOP TIER detergent gasoline. The additives and detergents in these fuels can reduce the amount of build-up in engines that adversely affects performance and shorten the life of an engine. Retailers selling TOP TIER gasoline can be found at [www.toptier.com](http://www.toptier.com).

**Never use E-85 or other E- fuels.** This type of fuel does not contain sufficient additives to protect the engine nor perform to expected standards.

**Never use leaded fuel.** Monsoon Engines are designed and constructed to run properly **ONLY** on unleaded gasoline. If finding unleaded gasoline is an issue for a boat owner, check with your authorized Cobalt dealer to locate unleaded gasoline.

**Never use gasoline containing higher than ten percent (10%) ethanol.** Use of gasoline containing 15 percent (15%) ethanol is prohibited in recreational boats and will void the warranty. Some fuel contains MBTE (methyl butyl tertiary ether) as a blend to enhance octane. Blended fuel is permissible as long as it is blended and does not exceed the percentage allowed.

**Never use gasoline that contains any methanol.** This type of fuel can cause corrosion to some of the engine parts, and such damage would not be covered under warranty.



**CAUTION**

Always verify that the fuel fill access is closed when the engine is running. Failure to do so may allow water to enter into the fuel system. Such intrusion could result in damage to the engine and is not covered under warranty.

When fueling the boat outside the United States or Canada, verify the chemical components of the available gasoline. You must use only approved fuel. Work with your authorized Cobalt dealer to locate appropriate gasoline for use.



### When the Boat Is Not in Operation (Fuel)

When properly maintained, boats can reasonably be expected to be ready for operation when they are not used for a period of two (2) weeks or less. Longer than two (2) weeks requires particular attention to fueling, among other operations. If the engine does not start and run smoothly, it is likely that there are issues involving gasoline.

When allowed to sit for extended periods of time, fuel components can begin to separate or deteriorate. Any water that has intruded into the fueling system will separate, and because it is heavier than gasoline, will settle to the bottom of the tank. The current fuel system should not allow significant amounts of water into the system, but operators should always verify that the fuel filler cap is closed any time the boat engine is on.

**Any time the boat is not going to be used for a period in excess of two (2) weeks, Monsoon Engines recommends adding STA-BIL® fuel stabilizer to the fuel tank. Although there are other anti-degrading stabilizers on the market, Monsoon Engines has found that STA-BIL®, when used properly, protects engines and fueling systems from the harmful effects of storage in most instances. Note, however, that even stabilized fuel can cause an engine to idle poorly and run less effectively until the older fuel has been used up. This kind of damage is not covered under warranty.**

Even with the use of STA-BIL®, long-term storage with fuel in the tank and fueling system can result in degradation of the fuel. This can cause the engine to perform poorly until the fuel is used, but in some instances can cause permanent damage to the fuel system and/or engine. Such damage is not covered under warranty.

If the boat will be stored for a significant period of time, such as an entire off-season, Monsoon Engines recommends filling the fuel tank full and adding STA-BIL®. Because STA-BIL® will eventually degrade, boat owners should follow the instructions provided by STA-BIL® regarding storage period, temperatures, amount of

mix, and any other information provided by the manufacturer of STA-BIL®.

**NO ADDITIVE OTHER THAN STA-BIL® IS APPROVED; USE OF ANY OTHER ADDITIVE MAY VOID THE WARRANTY.**



### Electrical System

**It is important that operators/owners review the boat's entire owner's manual to properly understand and identify information provided regarding the engine.**

Sensors will alert the boat operator when the oil pressure and engine temperatures are outside acceptable parameters. All alarms should be taken seriously, and boats should return to shore as soon as possible. Seek assistance from your authorized Cobalt dealer to determine the cause and solution to any problems that have been indicated.



### Alarms

**Note:** Audible alarms are a function through the instrument panel and/or the stereo system. The alarm system is equipped on all boats regardless of optional equipment. In general, an alarm sound is an indication that a potentially serious issue exists.

The low-voltage alarm functions when the battery system charge has fallen to a level that could result in the boat becoming unable to continue the outing.



### Cooling System

**All Monsoon Engines feature a hybrid of raw water cooling and closed cooling. Peak Sierra Brand, 5-year, 100,000-mile, Marine Grade Coolant (propylene glycol) in a 50/50 mix with distilled water is strongly recommended.**

From an empty engine (no coolant in engine or expansion tank) to the proper amount of coolant/water mix will require approximately 2.5 gallons. Directions for maintaining proper levels are provided in the *Care and Maintenance* section.

Without the need for a radiator such as used by land-based engines, the functionality of the cooling system is dependent upon operation within a body of water or maintaining the appropriate level of coolant/water in the system. Reducing operational heat from the engine is critical to ensuring the engine continues to perform. As Monsoon Engines are configured, temperatures in excess of 200°F (93°C) are considered to be overheating situations.



**CAUTION**

**NEVER run the boat engine with the boat out of a body of water! Even in closed cooling systems, some external**

water is used in the cooling process. Without water to circulate in the system, the engine will quickly overheat and can cause permanent damage that is not covered under warranty!

 **CAUTION**

Be certain to read the Care and Maintenance section of this owner's manual for important information regarding routine and regular functions that must be performed. Some of these tasks overlap engine and boat component attention and should never be skipped. Failure to perform care and maintenance can result in damage to the boat and engine that is not covered under warranty.

 **CAUTION**

Regularly review the engine temperature information provided on gauges or video screen. Warning lights and alarms also are part of the system to provide early warning when engine temperatures begin to exceed acceptable levels. Continuing to operate a boat that is overheating the engine will result in engine failure eventually. Ignoring or failing to take proper steps to reduce the engine temperature, resulting in damage, is not covered under the warranty.

If an engine overheats, consider several factors before shutting down. **(Turning off the engine when it is overheated may not provide immediate relief, and in some instances can actually cause additional harm.)**

If the boat has been idling for a prolonged period of time and the engine becomes overheated, attempt to reduce the temperature by operating the boat at a higher speed, preferably at normal running speed. This will increase the speed of water flowing through the cooling system, *assuming there is sufficient fluid.*

If the boat has been running at a higher rate of speed for a prolonged period of time and overheats, reduce speed for a few minutes to see if the temperature goes down. Running at wide-open-throttle (WOT) for too long can challenge the cooling system.

If there is no immediately discernible cause for overheating, or if the temperature does not begin to descend back to the normal range, turn off the engine and carefully open the engine compartment **(but never if there is an odor of fuel)**. Ambient air should eventually cool the engine, but if there is resulting damage to the engine from overheating, it may not restart, and the boat may need to be towed to shore.

 **WARNING**

**Never directly touch an overheated engine. Temperatures can exceed 200° Fahrenheit (93° Celsius), which would cause instant and serious burns, even through gloves or clothing.**

The water pumps on the engine that circulate water and coolant throughout the engine during operation are essentially inaccessible to the consumer. The circulation pump, which circulates coolant, is located on the bottom of the front-end accessory drive. If it requires attention, that should be done by a service technician at an authorized dealership.

Another pump, the raw water intake pump, is utilized to draw and circulate water from the body of water in which the boat is operating to increase the cooling effect for the engine. Water is brought into the cooling system through the outdrive water pickup. Please consult your outdrive owner's manual for the specific location.

As part of the routine annual maintenance, the raw water pump should be inspected, with particular attention to the impeller. The process for inspection is explained in the *Care and Maintenance* section. **If the boat is operated in shallow or brackish water, or if the boat is run aground, the impeller should be checked regularly. Silt, sand, dirt and weeds can accelerate the deterioration of the impeller.**

**Monsoon Engines are equipped with a flush kit. The process for properly using a flush kit is explained in the Care and Maintenance section.**

**NOTICE**

**Verify that the flush cap is tight before each outing, or it will suck in air and could damage the cooling system. Such damage is not covered under warranty.**

Most often, the cause of overheating is either marine growth clogging the raw water intake or insufficient coolant/water. If there is debris, even in small amounts, in the body of water during usage, it is likely that some of the marine growth can accumulate in the cooling system.

 **CAUTION**

**Except for the raw water impeller, consumers should not attempt to inspect or repair components of the cooling system. Most are inaccessible. All can be inadvertently damaged if not properly accessed, often necessitating specialized tools. Attempting unauthorized inspection or repair can void the warranty.**



## Coolant Requirements

In the closed cooling system, verify that there is sufficient coolant/water in the system. (Coolant and water may be required to be mixed, depending on the brand of coolant, most likely in a 50/50 mix.) Because a closed cooling system retains and recirculates coolant, an additional step prior to every outing is necessary: Before

starting the engine, while it is still cool to the touch and does not burn skin, check the coolant reservoir level. The instructions for this critical step are explained in the *Care and Maintenance* section.

### NOTICE

**NEVER use ethylene glycol or Dex-Cool antifreeze coolant. Such coolants are not formulated for the requirements of the Monsoon Engine. NEVER mix the approved propylene glycol coolant with any other type of coolant, including ethylene glycol or Dex-Cool, even in small amounts. These different formulations do NOT mix and will not provide the required cooling protection for the Monsoon brand engine. Mixing coolants may damage the cooling system.**

**Monsoon Engines recommends using Peak Sierra Brand, 5-Year, 100,000-mile Marine Grade Coolant in a 50/50 mix with distilled water to keep the warranty in effect.** Peak Sierra is an environmentally friendly coolant.

While some evaporation occurs naturally, it should not occur at an accelerated rate. If a closed cooling tank has significantly lost coolant, especially if it is nearly empty, a potentially serious issue exists. Present the boat to an authorized Cobalt dealer for analysis and correction, prior to starting the engine.

### NOTICE

**Coolant should be flushed from the system and fully replaced every two (2) years on the engine, and the cooling system should routinely be checked for proper fluid level and any leaks.**



## Exhaust System



**Always operate the blower for several minutes (at least four [4] minutes) prior to starting the engine. Failure to perform this necessary function could result in an explosion of the accumulated fumes within the compartment, resulting in serious injury or death.**

Always operate the blower for the required four (4) minutes prior to starting the engine. This allows the dispersing of fumes that otherwise allowed to accumulate could result in an explosion.

Although the fuel system works very efficiently, there will always be some gaseous by-product as a result of operating an internal-combustion engine. These gases, along with the water used to cool the engine (in addition to the closed cooling system) are routed out of the boat

by way of the exhaust manifolds on each side of the engine, and it is expelled out of the system at the transom.



**Never allow anyone to be on the swim platform, transom seating or sun pads when the engine is running. Carbon monoxide fumes are colorless and odorless. Illness and death can result from breathing fumes, even before a person is aware of breathing them.**

Although much of the exhaust is dispersed into and through the water, fumes still reach the swim platform and transom area of the boat, including the sun pads, and should be avoided.

Always allow the exhaust manifolds to cool before touching them. (The manifolds are on the upper part of the engine on both sides.) Engine operation will result in the manifolds becoming very hot, and touching could result in burns.

### NOTICE

**Engines equipped with catalyst exhaust manifolds may produce an unusual odor. This is typical of engines with a catalytic converter exhaust system. If you are uncertain about any odor, do not hesitate to contact an authorized Cobalt dealer for assistance in determining the cause and potential for concern.**

The boat is also equipped with an air ventilation system that uses at least one natural air intake vent to help protect people onboard from dangerous fumes. Vent location(s) vary by model.



**DO NOT allow the ventilation intake to be covered up by towels, swim paraphernalia or any other item that potentially restricts the inflow of air for the proper ventilation of the blower system. Such restrictions can result in the accumulation of toxic fumes, which can lead to an explosion under certain circumstances. All types of restrict ventilation are dangerous and can lead to serious injury or death!**



**The State of California has determined that the engine exhaust contains chemicals that have been known by the State to cause birth defects, cancer or other reproductive harm. Never operate the boat if you or anyone onboard suspects that the exhaust or fuel system is not performing as designed.**

# BREAK-IN PERIOD

Breaking in marine engines is a different process from land-based vehicles. The first ten (10) hours of operation for your Monsoon Engine is critical for long life and enjoyable operation. When done properly, the break-in period will ensure peak performance.

The first hours of boat operation have critical requirements for engine break-in. Pay close attention to the gauge package for proper operation. Pay particular attention to the oil pressure and engine temperature information as these are the earliest warnings when something is not operating correctly. Alarms will sound if serious problems are encountered.

Also, check carefully for leaks. The break-in period is the most-likely time for leaks to appear, whether fuel, oil, water or exhaust. Verify that fluid levels are at the required levels. Listen for abnormal noises and pay attention to vibrations.

Any part of the operation that seems to be different from expectations should be checked with your authorized Cobalt dealer, especially during this break-in period.



## Break-In Procedure

All Monsoon Engines undergo a general pre-test run at the factory before shipping. The customer-based break-in period takes place for the first ten (10) hours of operation. Pay close attention to your boat's hour meter and follow the below listed break-in procedure.



The break-in procedures, which should be followed for the first ten (10) hours of operation as measured by the integrated hour meter, allow the engine components to properly seat and function in the usage thereafter. These procedures are as follow:

- Always allow the engine to warm up after it is started. The length of time varies depending upon conditions, but it is especially critical when operating in colder weather. Oil viscosity thickens at these times. Failure to allow it to warm up can cause severe damage to the engine, which is not covered under warranty. **This is time in addition to the four (4) minutes venting the engine compartment.** Engine temperature information is available on the gauge package at

the console. Always verify that the engine feedback information is within acceptable limits and no alarms show or sound before leaving the dock. Often, symptoms of potentially stranding issues will be noticeable at the beginning of the outing.

- **Vary engine speed every 10-15 minutes, but DO NOT EXCEED 3,500 RPM with a light load for the first (1) hour.**
- **After the first hour, higher RPMs are allowable up to, but not exceeding, 5,000 RPM, but operators must avoid operating at one continuous speed (RPM) for more than 15 minutes at a time. Varying the speed is important! NEVER RUN AT WIDE OPEN THROTTLE (WOT) DURING THE BREAK-IN PERIOD!**
- Never operate at idle speed for extended periods during the break-in period. Occasionally return the shifter/throttle to **NEUTRAL** for a cool-down period, but do not operate at idle speed for extended periods. It is better to turn **OFF** the engine than to idle indefinitely.
- Operate above 1,500 RPM carefully. If the body of water is choppy or if there are other challenges present, operate at lower RPM. Boating conditions can add strain to engine operation.
- Always shift and accelerate smoothly during break-in. Avoid rapid operational changes. Plane the boat quickly as lower speeds can put more strain on the engine.
- **DO NOT complete the first oil change before fifty (50) hours.**

## NOTICE

Failure to have the initial, 50-hour oil change performed by an authorized Cobalt dealer may result in the voiding of the engine portion of the warranty if it is determined that engine issues could have been analyzed and/or prevented through the dealer's inspection at that 50-hour service interval.

- **DO NOT load the boat to its maximum load capacity until after the ten (10) hour break-in procedure is completed. Maintain the correct oil level as measured on the dipstick during the break-in period.**
- Monitor the gauges closely as these are your first line of defense.
- Abnormal vibrations or unusual noises could be symptomatic of additional problems that are not registered by the gauges.
- **The boat must be returned to an authorized Cobalt dealer for the first service/scheduled maintenance.** The purpose is to allow a trained technician to interpret any signs of malfunction or anomaly that may have occurred. Early symptoms are critical to avoiding potentially damaging events that might not be covered under warranty.

- The dealer will change oil as well as check the cooling fluid.
- Verify that the propeller remains properly mounted and undamaged.

**CAUTION**

Never operate at wide open throttle (WOT) continuously, even after the break-in period. WOT allows boat operators to quickly get the boat out of potentially dangerous situations and is intended for only brief use. WOT places exceptional stress and strain on the engine components. It can also test the boat operator's ability to control the vessel. Loss of control not only could cause an accident that damages the boat but could also potentially injure persons onboard.

**NOTICE**

Check the engine oil level frequently during the break-in process. It is normal for the engine to use oil at this time, often at a greater rate than will occur later. The dipstick is located mid-block on the starboard side of the engine, between the intake and manifold. It has a circular yellow

handle. Add only full-synthetic 5W30 engine oil for M-Series engines. **DO NOT USE ENGINE ADDITIVES AT ANY TIME. ENGINE ADDITIVES WILL VOID THE WARRANTY.**

At fifty (50) hours the engine oil and oil filter **MUST** be changed. Monsoon Engines strongly recommends that this procedure be done by the authorized Cobalt dealer as the service technicians are trained to look for the difference between acceptable signs of engine wear as differentiated from abnormal signs. This can make the difference in ensuring a long life for your engine.

If your dealer is not conveniently close by, instructions for oil and filter change procedures has been provided for oil changes **AFTER** the break-in, 50-hour oil change. After the break-in period, follow the instructions provided.

**NOTICE**

Failure to follow break-in instructions can result in long-term performance issues or damage to critical components of the engine. Such failure is not covered under warranty.

## CARE AND MAINTENANCE

### Flush Kit



Monsoon Engines are equipped with an inline flush kit that can be used to clean out the operational areas of the engine.

Open the fixture, then attach a water hose with a fresh water

source (without water running) to the fixture. When it is secured, fully turn on the hose (less water flow will be inadequate to flush the system and could result in damage to the system that is not covered under warranty).

Start the engine to allow the water pumps to flush the system. **At no time should you ever exceed 1,100 RPM.** The water flow is insufficient to cool the engine via the flush kit if the RPM exceeds 1,100. Water will exit through the exhaust system in approximately 20-30 seconds.

**Run clean water through the system for approximately 8-10 minutes.**

After running clean water through the system as prescribed, turn the engine **OFF**. Turn off the water source for the hose. Disconnect the hose and reinstall the flush kit cap securely. If the cap is not secure, air will be introduced into the system that will adversely affect the boat's cooling system.

**NOTICE**

Inspect that the flush cap is tight before every outing or it will suck in air and could damage the cooling system. Such damage is not covered under warranty.



### Salt Water Care and Maintenance

**NOTICE**

Throughout this section, instructions directing you to "rinse" the engine should be interpreted as "lightly spray or mist with clean, fresh water." Do not apply water to any engine component with direct, high-pressure water, especially electrical components such as the starter and the alternator. Also, it is important to avoid wetting certain components such as the flame arrestor, as doing so can introduce water into parts of the engine that should never have water. Damage that occurs to the engine in this way is not covered under warranty.

## NOTICE

**Failure to follow ANY of the Saltwater Care and Maintenance instructions for care and maintenance will void the warranty. Significant damage occurs to the engine and boat if proper maintenance is not followed as outlined in this owner's manual. Damage that occurs to the engine because of corrosion is not covered under warranty.**

While Monsoon Engines uses quality metal components chosen for their durability as well as attractive appearance, all metal eventually reacts to water exposure. When boating in brackish or salt water, cleaning the engine internally and externally after every outing is critical to preventing rust, corrosion, and/or deterioration of engine components and maintaining warranty coverage. Because such damage can affect engine performance and function, proper care and maintenance is also a safety matter.

Monsoon Engines are equipped with a closed cooling system that reduces the amount of water utilized from the body of water during operation. However, some water is necessary to be drawn on board and circulated throughout the engine, which exposes some engine components to salt or brackish water. To prevent corrosion from brackish or salt water in the cooling system, you should flush the engine after every outing; the explanation of how to properly flush the engine appears in this section.

If you notice rust or deterioration of metal components below the waterline, even when operated regularly in fresh water, this should be brought to the attention of an authorized Cobalt dealer as the engine may also be affected.



## Routine Salt Water/Brackish Water Protection

*After every outing:*

1. Rinse and thoroughly air dry all exterior metal engine components; and
2. Flush the engine with clean water.

Additionally, it is recommended to apply Corrosion Block or WD-40 Long-Term Corrosion Inhibitor at least monthly and prior to any long-term storage.



## WARNING

**Engines operated in salt water, brackish water, or polluted fresh water must be thoroughly rinsed after EACH outing. The corrosive properties of these types of water will cause damage that is not covered under warranty! Hardware—even hardware chose for its anti-corrosive properties—that is damaged by salt/brackish/polluted water may eventually fail, which could result in serious injury or death to persons on board.**

Monsoon Engines has determined that the use of Corrosion Block is necessary to ensure long life for metal components. The use of Corrosion Block (available at [www.corrosionblock.com](http://www.corrosionblock.com)) as directed on the bottle or can is required to keep the warranty in force. *(While Corrosion Block is the recommended product, WD-40 Long-Term Corrosion Inhibitor may be used. Regular WD-40 cannot be used as it does not contain all the protective ingredients of the Long-Term Corrosion Inhibitor.)*

Avoid getting Corrosion Block on other, non-metal surfaces, particularly avoiding vinyl seats or soft-grip flooring. If this occurs, clean immediately as directed by the product's directions to avoid stains that are also not covered under warranty.

## NOTICE

**Failure to use Corrosion Block as directed on the product label will result in the nullification of Monsoon Engine's Limited Warranty for instances of corrosion damage. Monsoon Engines uses only marine-rated and marine-grade fasteners on all models. If, at any time, it is necessary to replace any fasteners, seek guidance from an authorized dealer to ensure that such replacements meet the requirements for operation in a marine environment.**

To properly protect and ensure long life for vulnerable components, following the operation in salt or brackish water provide extra attention to the cleaning process. You will need microfiber towels and Corrosion Block or WD-40 Long-Term Corrosion Inhibitor.

All metal areas should always receive special attention when cleaning after boating in salt/brackish/polluted water.

- **Components requiring extra attention:** Any metal seacocks or ball valves, stainless steel hose clamps, starter, engine mounts, and alternator.

**Be especially careful to avoid getting Corrosion Block or WD-40 Corrosion Inhibitor on the areas of the pulleys that make contact with the belt. Corrosion Block and WD-40 Corrosion Inhibitor could cause belt slippage.**



## Corrosion in Fresh Water

While fresh water is far less corrosive than salt or brackish water, there can still be a level of corrosion associated due to the water composition. Therefore, even when using the engine in fresh water it is recommended that a regular inspection for corrosion of engine components be made, and the use of Corrosion Blocker or WD-40 Corrosion Inhibitor applied monthly or as needed.



## Engine Oil Maintenance

Replacing the oil filter and engine oil is an important part of the engine maintenance. Due to environmental concerns, Monsoon Engines recommends having an authorized Cobalt dealer complete this important function. For those who feel confident they can complete this maintenance step with guidance, the following steps must be followed:

The engine oil must be replaced every fifty (50) hours of operation. While there is a break-in procedure for the first ten (10) hours of operation, an engine oil change will not be required until the first fifty (50) hour mark, and subsequently every fifty (50) hours or annually (whichever comes first).

### NOTICE

**Have nine (9) quarts of 5W30 full-synthetic engine oil available for the 5.3L or 6.2L M-Series engines. The use of any other oil or fluid may void the warranty.**

### NOTICE

**The engine oil level should be checked before every outing to ensure the proper fluid level. A lack of oil prevents proper lubrication and causes substantial damage to the engine.**

Whenever possible, run the engine for approximately five (5) minutes. This will heat up the oil to a better viscosity for draining.

### Draining the Oil

- Have a drain pan or container ready. Never pour used oil on the ground or into the water. This is illegal in most instances and has a negative environmental impact. The oil drain line is located on the side of the engine oil pan through a fitting, and it is approximately four (4) feet long.
- If a siphon pump is not available for use in this process, run the drain hose through the transom drain plug location with the boat out of the water (removing the transom drain plug while in the water could result in the boat taking on water and sinking). Because the line will not feed through the drain plug with the line cap on, raise the line above the oil pan. This creates a P-Trap at the end of the drain hose, which is fed through the transom drain plug to allow the gravitational flow of used oil.
- If a siphon pump is available, remove the drain line cap, create a seal on the siphon hose and start the pump. About eight-to-nine (8-9) quarts of used oil should drain into the catch container. (Typically, engines burn a small amount of oil used between oil changes.)

### Replacing the Oil Filter

- Oil filters are located on the front of the engine.
- Remove the oil filter housing cap.
- Use a tool designed for removal or installation of only oil filters. Other tools may crush the filter and release used oil into the engine compartment, the boat or the work area. Remove the cap by turning counterclockwise, and replace by turning in the opposite direction. Never force the oil filter housing cap. It should be on the engine securely, but it should release with only hand force when using tools. Some small amount of residual used oil may be inside the filter. Keep a shop rag or similar catch under the filter as it is removed from the boat.
- Inspect the oil filter to examine for any evidence of metal shavings or other unwanted signs of engine wear. Be sure to do so over a container. Clean up any oil that ends up spilled.
- Also examine the o-ring on the cap. If it is damaged, it should be replaced.
- Secure the oil filter housing cap in place on the engine. Tighten securely by hand, but do not force the filter as it may damage or break the seal if over-tightened.

### Adding New Oil

- Replace the drain line cap on the drain line and thread the drain line back to the location adjacent to the oil pan.
- Remove the oil fill cap on top of the valve cover.
- Place a clean funnel within the oil fill cap.
- Pour approximately eight (8) quarts of oil in the engine through the funnel, allowing time for the fill to occur. (Having nine [9] quarts on hand allows you to top off as needed as the system could hold this much when all the lines are filled). As you approach the eighth (8th) quart, slow down. It takes a little time for the oil to move through the system. Start watching the fill line on the dipstick. Always clean the dipstick between readings to ensure accuracy.
- **Stop filling oil into the system when you reach the FULL mark on the dipstick, regardless of how much oil has been added. Over-filling can damage the system. NEVER REUSE OIL. ONLY NEW OIL SHOULD BE USED.**



### How to Check the Engine Oil Level

- With the engine **OFF** for several minutes (allowing oil to drain back to the oil pan), remove the engine oil dipstick from the top side of the engine.
- With a clean, dry cloth, wipe the dipstick free of residual oil and reinsert it into the engine.
- Withdraw the dipstick and note where the measurement reaches on the dipstick.

- If the engine oil level is at or below the fill line, add new oil as described above. Never reuse oil or overfill as either can damage the engine, and that is not covered under warranty. Use only the oil specified for your installed engine.



## How to Check the Engine Coolant Level



**WARNING**

Never open the coolant reservoir when the engine has been running. This check should be done prior to starting the engine. During operation, pressure builds up in the reservoir. Opening it before the cooling system has had time for pressure relief likely will result in an eruption of fluid. It will also be sufficiently hot to seriously burn skin. Always allow sufficient time for the fluid to cool and return to pre-operation levels.

The coolant must be propylene glycol coolant

**only. Never use ethylene glycol or Dex-Cool, nor ever attempt to mix coolants as they will not mix properly. Use of unapproved coolant will void the warranty.**

With the engine turned off and cool, open the engine compartment hatch and locate the coolant reservoir. The reservoir will be located on the engine between the manifold and the intake diagonally behind the alternator. The reservoir features a **FULL** marking. Do not fill above this level. The reservoir requires expansion room while in operation. Therefore, the **FULL** marking is slightly lower than the top of the tank.

It may be necessary to periodically add coolant as a small amount of evaporation occurs naturally. When adding coolant, use only a 5-year, extended warranty antifreeze (propylene glycol), either a premixed 50/50 mix or create a mix of 50 percent (50%) extended warranty antifreeze plus 50 percent (50%) distilled water. Do not use tap or other types of water as other elements in the water can cause build-ups or deposits within the closed cooling system. This can interfere with proper operation and resulting damage is not covered under warranty.

## WINTERIZING THE ENGINE

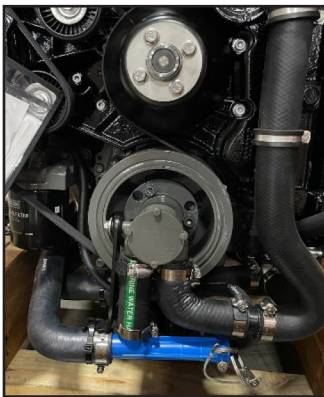

To winterize a Monsoon Engine, begin by performing a normal flushing of the engine. See instructions in *Flush Kit*, earlier in this section of the owner's manual.

After flushing the engine, open the drain plug (see *images*) and allow water to drain

With the boat shifter in



- **DO NOT EXCEED 1,100 RPM;**
- **DO NOT TAKE THE BOAT OUT OF NEUTRAL GEAR;**
- **DO NOT RUN THE BOAT FOR MORE THAN THIRTY (30) SECONDS.**

Run until there is no longer water coming out of the drain plug, then stop the engine. Leave the drain plug open for the duration of storage/non-use.

### NOTICE

When recommissioning the engine, be sure to close the drain plug. Running the engine with the drain plug open will allow water to enter the engine compartment, which may damage the engine. Such damage is not covered under warranty.

### NOTICE

Failure to properly perform regular maintenance, plus storage/winterization procedures as described in this manual, is likely to result in damage to the engine. Such damage is not covered under warranty.

**NEUTRAL**, start the engine and allow it to idle for about 5-10 seconds.

During this process:

# MONSOON ENGINE MAINTENANCE SCHEDULE

Component	Service	Annually*	First 10 Hrs	First 50 Hrs	Every 150 Hrs	Every 300 Hrs	Every 2 Yrs
Oil & Filter **	Change	X**		X**			
Raw Water Impeller	Change	X***		X			
Coolant	Inspect	X	X				
Coolant	Change						X
Serpentine Belt	Inspect	X****		X**			
Serpentine Belt ****	Change					X	
Air Filter	Inspect	X	X				
Air Filter ****	Change						X
Fuel Filter*	Change	X*			X		
Spark Plugs	Inspect					X	
Spark Plugs	Change						X
Shaft Alignment	Inspect	X	X		X		
Heat Exchanger	Inspect	X					
Sacrificial Anodes	Change	As Needed					

- \* *Whichever comes first.*
- \*\* *It is recommended to 1) change oil and oil filter; and 2) inspect the serpentine belt, every 50 hours or annually (whichever comes first).*
- \*\*\* *First of the season.*
- \*\*\*\* *Replace sooner if regular inspection indicates wear or damage.*

**It is always recommended that these requirements be performed by an authorized Cobalt dealer. Authorized dealer technicians have proper equipment, training and resources to best meet the service requirements. Please note that routine maintenance costs are not covered by Monsoon Engines Limited Warranty.**

# RECOMMENDED MERCURY MARINE OUTDRIVE MAINTENANCE SCHEDULE

Component	Service	After Every Outing	First 20 Hrs	Every 100 Hrs
Drive Gear Lubricant	Change		X	X
Coupler	Lubricate			X
Alignment	Inspect			X
Drive U-Joint Spline	Lubricate			X
Drive U-Joint O-Rings	Inspect			X
Drive U-Joint O-Rings	Lubricate			X
Propshaft Splines	Lubricate			X
Propshaft Spline Nut Torque	Inspect			X
Trim Pump	Inspect	X		
Power Steering Fluid	Inspect	X		
Steering System	Lubricate			X

## WARNING

**Operating, servicing, and maintaining a recreational marine vessel can expose you to chemicals including engine exhaust, carbon monoxide, phthalates, and lead, which are known to the State of California to cause cancer and birth defects or other reproductive harm.**

**To minimize exposure, avoid breathing exhaust, service your vessel in a well-ventilated area, and wear gloves or wash your hands frequently when servicing this vessel. For more information go to [www.P65warnings.ca.gov/marine](http://www.P65warnings.ca.gov/marine).**



154 • ENGINE OPTION



# Trailer Option



# COBALT TRAILERS

Cobalt Boats now offer company-built tow trailers as an option. Cobalt Trailers are engineered and constructed specifically for Cobalt Boats. Trailers designed for our models feature an incomparable fit. Properly loaded, the weight of the boat is fully supported, relieving stress to key compo-

nents in the boat hull.

Information follows that offers significant safety information, as well as the care and maintenance required to keep the trailer warranty in effect, and to ensure the boat's protection over the long life of both the boat and trailer.

## REPORTING SAFETY DEFECTS

**If you believe that your vehicle has a defect which could cause a crash or could cause injury or death, you should immediately inform the National Highway Traffic Safety Administration (NHTSA) in addition to notifying Cobalt Boats.**

**If NHTSA receives similar complaints, it may open an investigation, and if it finds that a safety defect exists in a group of vehicles, it may order a recall and remedy campaign. However, NHTSA cannot**

**become involved in individual problems between you, your dealer, or Cobalt Boats and Malibu Trailers.**

**To contact NHTSA, you may call the vehicle Safety Hotline toll-free at 1-888-327-4236 (TTY:1-800-424-9153); go to <http://nhtsa.safercar.gov>; or write to: Administrator, NHTSA, 1200 New Jersey Avenue SE, Washington, DC 20590. You can also obtain other information about motor vehicle safety from <http://www.safercar.gov>.**

## Legal Requirements for Towing

Be aware that many state and local jurisdictions in North America have specific laws and/or ordinances regarding towing. It is the operator's responsibility to research and become familiar with specific requirements that are in effect in the areas in which you will be towing. Information is often available online, but you can also contact your area's motor vehicle office for directions and details.

If you will be taking your boat and trailer on vacation or to an outing in another jurisdiction in which you do not regularly tow, it is necessary to determine the appropriate laws for that area. Law enforcement officers will expect you to have knowledge of applicable laws and ordinances.

Laws can cover, but are not limited to, such components and matters as lights, brakes, safety cables, driver's license requirements, trailer licenses and permits, and overall size. Some areas may also have insurance requirements. Determine whether you must carry liability insurance specifically for towing. If you have financed your boat and/or trailer, your lender may also require full coverage. This is also your responsibility to determine and to secure as needed. **Cobalt Trailers does not assume any responsibility for your knowledge and confirmation that the requirements have been met.**

## Basic Safety Rules

Make sure you understand all of the operating instructions prior to attempting to operate this trailer. Accidents are generally caused by the operator's failure to follow basic safety rules or written precautions. Most accidents can be avoided if the operator is completely familiar with the trailer and its operation, follows recommended practices, and is able to recognize and avoid potentially hazardous situations.

Failure to observe the safety recommendations contained in this manual may result in severe personal injury or death to you or to others. Use caution and common sense when trailering. Don't take unnecessary chances! Some basic safety rules are outlined in this section of the manual.

**Cobalt strongly encourages people towing, including non-owners of trailers who are towing, to first read all safety material available and to become familiar with laws and ordinances pertaining to towing and driving within applicable jurisdictions. It is advisable to also pay attention to insurance requirements and to fully insure the trailer and boat and be prepared for any potential liability. Review the tow vehicle's owner's manual as well, prior to operation and towing.**



# CONNECTION TO THE TOW VEHICLE

## Preparation



**WARNING**

The Gross Vehicle Weight Rating (GVWR) is the total estimated weight that a road vehicle loaded to capacity (including the vehicle weight itself) can be expected to tow safely. This includes the trailer, boat engine, any liquids including fuel, and items carried on and in the tow vehicle and the boat. This is a maximum established by federal mandate and enforced by law enforcement authorities. Overloaded capacity can cause the trailer to disengage from the hitch, which could result in serious injury or death, in addition to damage that is not covered under warranty.



Never tow the trailer and contents, including the boat, behind a vehicle that is not rated to tow this weight. Also, be certain that the tow hitch is correct. Additional information follows regarding this important factor.

On the left front side of the trailer is a certification label that shows the maximum load-carrying capacity of the trailer. The GVWR will be indicated on this label.

Many truck stops offer complimentary weigh scales. If you are not able to locate scales, nor compute the total GVWR from the individual components being towed, contact your DMV for assistance in finding scales in your area.

Never tow the trailer and contents, including the boat, behind a vehicle that is not rated to tow this weight. Also, be certain that the tow hitch is correct. Additional information follows regarding this important factor.



**WARNING**

Remove wakeboards and skis from above the boat deck (i.e., from the tower) before towing. Even with careful attachment to the racks, these paraphernalia can disconnect and become projectiles that threaten other vehicles following.



**WARNING**

Never tow with water in the ballast or bilge systems! All water must be released prior to loading the boat on the trailer. Water on board can cause an imbalance on the trailer that further heightens the likelihood of an accident due to loss of control when there is insufficient percentage of weight at the tongue and hitch.



## Trailer Hitch

A weight-carrying hitch should be used for towing a Cobalt trailer. No other hitch type meets the requirements for safely operating the trailer. The tow vehicle may have requirements regarding an acceptable hitch, so verify by reading the tow vehicle's owner's manual for direction. A weight-distributing hitch can be used in an emergency, but if the trailing arms are used, the Cobalt trailer's brakes will not operate.

Hitch up with the trailer in a level position to the tow vehicle. Note that attempting to tow with a trailer that is not level across the length of the trailer could either cause the brakes to prematurely activate or not activate at all, potentially causing a loss of control.

If the hitch height is incorrect and does not allow the trailer to be level, it may be necessary to install air-pressure adjustable shock absorbers on the tow vehicle. If a weight-distributing hitch is installed, change out to a weight-carrying hitch instead. Or consult with the tow vehicle manufacturer's authorized dealer for other assistance.

In general, for Class 4 rigs, (5,000-10,000 lbs.) a ball of 2" or 2-5/16" is required.



## Safety Cables

The safety cables can prevent a trailer from totally disengaging from the hitch. If it becomes necessary in



the future to replace the cables, ensure that the replacement cables meet the Society of Automotive Engineers (SAE) J684 standard for trailer hitching and coupling. The cables must match or exceed the trailer's GVWR.

Cables must be as centrally attached as possible to the bumper or frame of the tow vehicle. The hitch should provide a location through which the safety cables can be attached. Holes or rings should be on both sides of the hitch ball.

Most states require that the safety cables be criss-crossed under the trailer tongue prior to being attached to the other hole or ring location. If the trailer disengages, these cables should prevent the trailer tongue from falling onto the tow surface.

The cables should be attached as tautly as possible but still allow for turning, including close quarters turns.

The trailer also is equipped with a surge brake breakaway cable. This cable, explained further in this section of the owner's manual, must also be attached to the tow vehicle frame, securely but allowing for turns.

A truck or van with a step bumper requires eyebolt or equivalent safety cable attachment, which meets the Society of Automotive Engineers: SAE J684 Standard. Refer to the tow vehicle's owner's manual for additional details. This is critical as some tow vehicle's safety cable attachments may be too small.

### **WARNING**

**Safety cables and the breakaway cable must be securely attached to the tow vehicle, while allowing for turns. Failure to do so could result in serious injury or death, as well as property damage to other persons and vehicles on the road if the trailer becomes disengaged from the tow vehicle.**



### **Breakaway Cable**

If the cable clip is missing, or it has been broken by the cable being pulled, first check and attempt to release the emergency brake mechanism by pressing up on the brake release tab under the actuator nose, right behind the tow ball insert location. Press up on the brake release tab, and if a metallic clunk or sound of a spring releasing is heard, that means the emergency brake mech-



anism had previously been engaged. When pressing up on the brake release tab, if it moves up and down freely with just the resistance of its spring, then the emergency brake system was likely not previously engaged.

Be sure the emergency brake mechanism is not engaged prior to towing. If the cable was pulled hard enough to break the clip on the cable, the cable and clip must be replaced, and the actuator checked for proper function. Your authorized Cobalt dealer can obtain a cable replacement kit that is specific to the actuator model used on your trailer.



### **Weight Distribution**

A range between 5 to 10 percent (5%-to-10%) of the total weight on the trailer must rest at the coupling ball when the tongue is parallel to the ground. This determination can be made with a bathroom scale, provided you know the total weight of the trailer, boat, and items onboard.

Some vehicle manufacturers limit tongue weight to a maximum of two hundred (200) pounds when using certain types of weight-carrying, bumper-mounted hitches. Check the tow vehicle's owner's manual to determine the correct distribution.

### **WARNING**

**Failure to properly distribute weight in the boat and across the trailer can result in the trailer fishtailing (swaying from side-to-side) in a dangerous fashion that puts not only the total rig at risk but also other vehicles and persons on the road. Adequate download on the hitch ball is critical!**

## **HOW TO CONNECT TO THE TOW VEHICLE**

### **Attaching to the Tow Vehicle**

- Open the coupler mechanism. (*Instructions below*).
- If necessary, use the trailer jack to have the trailer at the proper height, which is just above the height of the ball on the tow vehicle.
- Hitch **ONLY** to a ball that is sized properly for the coupler.

- Back up the tow vehicle **SLOWLY** to the trailer. Many tow vehicles now have a backup camera that makes this process easier, but it will still require practice. If you do not have a backup camera, having a second person to offer hand signals can be helpful.



### **WARNING**

When using a second person to assist in the backing up process to hitch the trailer to the tow vehicle, always watch in your mirror. Do not allow the person to stand between the tow vehicle and the trailer as they can be struck by the vehicle or caught between the tow vehicle and the trailer. Such activity requires common sense and care to avoid injury.

### **NOTICE**

Never move the trailer toward the tow vehicle. When the trailer is not fully hitched up, the brakes are not operational.

- Release the coupler latch. The hitch pin should fit easily into the hole. If it does not, this means that the latch is not completely closed. It will not close unless the coupler fits snugly over a properly sized ball. If the hitch pin is damaged or lost, it must be replaced prior to operating the rig.

### **WARNING**

The hitch pin must be properly installed and secure prior to operation. If it is damaged or missing, you can operate temporarily with a 1/4" or 5/16" shank padlock. Never operate without the hitch pin or padlock as the trailer and contents can become disengaged from the tow vehicle, which may result in an accident or damage that causes serious injury or death.



### **To Open the Coupler**

- Remove the hitch pin from the hole in the side of the coupler.
- While holding the button, raise the handle.



### **To Close the Coupler**

- Place the coupler over the ball.
- Lower the coupler.
- Close the handle. An audible sound will be heard. If the handle does not close easily, the ball is not fully within the socket. **DO NOT FORCE** the handle to close as it is likely that the ball is the wrong size and should be replaced.

### **CAUTION**

Never tow with the coupler handle open or partially open. If the handle will not remain closed, go back through the steps to ensure that it will close and stay closed. If you are unable to get the system to perform correctly, see an authorized Cobalt dealer for assistance. Failure to get the coupler secure could result in the trailer disengaging, which could lead to serious injury or even death.

### **NOTICE**

Cobalt trailers require a seven-pin connector. Some older tow vehicles may have a five-pin connector instead of a seven-pin connector. An adapter is available through the tow vehicle's manufacturer. This is required to allow the back-up lights and solenoid to operate correctly. Failure to ensure that the entire lighting system on the trailer is operating correctly can mean that other vehicles following or in the vicinity of your tow equipment may not be alerted when you shift into reverse. This could lead to vehicle damage or injury.



### **WARNING**

As part of the hitching-up process, late model tow vehicles are usually equipped with a sensor that reports when the trailer lights have been connected to the tow vehicle's connector. However, the LED light utilized on Cobalt trailers sometimes does not pull a sufficient load on the tow vehicle's electrical system to register. This situation can be simply remedied by the tow-vehicle's dealership.



### **Unhitching**

The coupler should easily unlatch, but if it does not, check to see if the ball is correctly sized, or if the trailer is parked on a hill, which will inhibit the ability to successfully open the coupler.



### **Hitching**

- After securing the coupler to the hitch ball, double-check that the hitch pin is properly installed, and the coupler handle secure.
- Cross the safety cables under the coupling, allowing only enough slack to enable turning when the rig is in operation.
- Attach the breakaway cable to the tow vehicle.

- Connect the trailer's seven-wire connector to the seven-wire connector of the tow vehicle and check that the lights are working correctly. (More information

follows in the *Trailer Components and How They Function* section of this chapter).

## CONNECTING TO THE BOAT

### Trailer Winch

The trailer winch is a manually operated device to assist loading the boat onto the trailer and maintaining it in position for proper towing. The following information is important in assuring control and protection for you and the boat:



- **Inspect the winch prior to every use.** Never use the winch if there is any sign of damage. Your authorized Cobalt Trailer dealer can assist you in repairs.
- **Firmly grip and hold on to the winch handle when the handle is not locked!** Letting go can cause the handle to spin wildly out of control if there is tension on the line. Lock the ratchet lever on the winch any time you will not be using it to load or unload the boat.

#### **WARNING**

**Failure to lock the ratchet lever on the winch when the boat is being loaded or unloaded or when there is tension on the line, can result in loss of control, with the handle spinning. This could result in serious injury. Also, the boat could slip off the trailer, causing damage that is not covered under warranty.**

- **The winch will have a rated capacity, which must not be exceeded.** This includes the weight of all items onboard. Water in the ballast and bilge systems should be released prior to loading to avoid exceeding weight limits.
- **The winch should not be fully extended prior to loading.** To operate properly, leave at least a couple of turns of strap on the winch.
- **The boat should be partially loaded on the partially submerged trailer by engine power.** More on this technique is explained later in this section. Using the winch as the sole method for loading puts undue strain on the winch strap and results in excessive wear.
- **Check the straps prior to each loading.** The straps

will wear with age, use, and exposure to the elements. Because of the importance in holding the boat secure for loading, unloading, and towing, never use worn straps. Replace with Cobalt-approved straps only.

- **As part of the maintenance program, the gears should be greased with a heavy-duty, marine-grade grease regularly.** This allows for continued proper operation and will help in the ease of operating the handle as well.
- **Attach the winch to the bow eye on the boat for loading.** The winch should never be attached to any other component of the boat.
- **Do not rely on the winch to be the only manner in which the boat is held on the trailer.** Use all other tie-downs as described in this section. The winch is insufficient to hold the boat in place.

#### **WARNING**

**Attaching the winch to any component of the boat other than the bow eye, and attempting to load the boat, can result in damage to the boat, which may result in serious injury or death. This is not covered under warranty.**



### Tie-Downs

As part of the security for towing, the boat is equipped with tie-downs fore and aft on the boat and optionally on the trailer. Seek assistance from an authorized Cobalt Trailer dealer to determine the location on your boat model and trailer as they vary by model. Also seek instruction for the proper way in which to tie or hitch the lines for both a secured boat, and ease of unlatching the hitches when you arrive at your destination.



# TRAILER COMPONENTS AND HOW THEY FUNCTION

## Trailer Jack

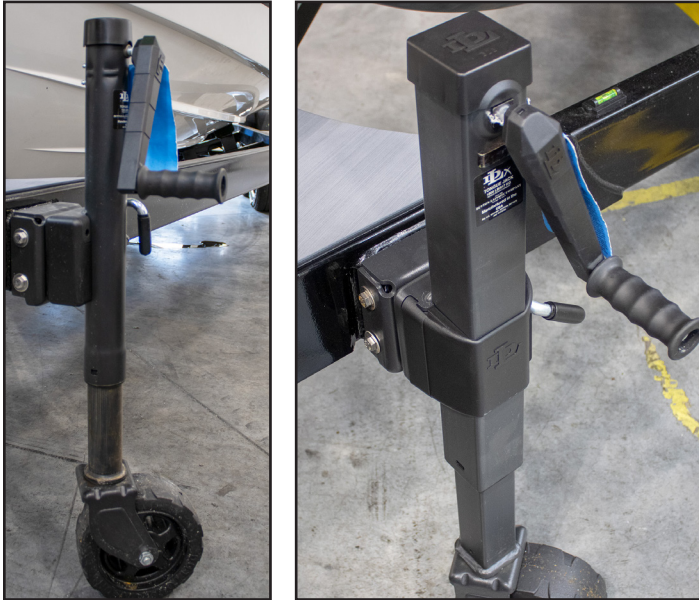

The trailer is equipped with a trailer jack, which serves several purposes. (Larger Cobalt models come equipped with a heavy-duty jack.)

The trailer jack can hold and lift the trailer to position for lowering on the hitch ball of the tow vehicle. It is also useful for assisting and balancing as a trailer rests free of the tow vehicle or is moved. Cobalt Trailers are also equipped with a level on the frame behind the jack to assist with ensuring the boat can be towed levelly.

Rotate the trailer jack so that it is vertical and snap the locking pin before placing any kind of load on the trailer jack. Always retract and rotate back into the horizontal position for stowing or towing.

Also snap the locking pin on the trailer jack prior to placing any kind of load on the jack. Failure to do so could result in the trailer jack collapsing or otherwise failing, which could lead to serious injury or death.

### NOTICE

**Failure to properly stow the trailer jack in a horizontal position, and lock in place, could result in damage to the jack or other trailer components that is not covered under warranty.**

The drive gear and rack-and-pinion that control the trailer jack movement should be periodically greased with a marine-grade grease. The wheel bearings in the jack and the coaster should also be periodically oiled to ensure that the components continue to operate as designed.

## Removable Guide Poles

Cobalt trailers are equipped with removable guide poles as standard equipment. The poles, located on each side of the trailer, assist in assessing the total width of the boat and trailer relative to towing or while backing up, as well as parking the trailer and boat inside/under shelter such as a garage.

Please note that, depending upon the state or jurisdiction in which the trailer is being towed, the guide poles may need to be removed while the trailer is in transit. **It is the responsibility of the tow vehicle owner/operator to determine whether the total width of the trailer at the guide poles exceeds the legal limits and remove the guide poles where necessary.**

The poles are held in place on the trailer with quick release pins. When the guide poles are removed, the poles and pins must be stored in a clean, dry location. This could be the bed of the tow vehicle; also some storage locations in the boat may be large enough to store them. Regardless of the solution, the poles and pins should be kept where they can be accessible as needed.



## Lights



### WARNING

**NEVER** operate the trailer, even during daylight, without verifying that the lights work properly. When the brakes are applied, it is critical that traffic following can see that you are slowing and/or stopping by seeing the brake lights come on. In the event of rain, running lights are required in most locations to tow the trailer. **Even assuming you will return prior to dark, events could occur that result in towing after dark.**

Cobalt trailers will integrate with most tow vehicle wiring harness requirements. If the harness will not connect to the plug, contact either the authorized Cobalt Trailer dealer for assistance or the tow vehicle's autho-

alized dealer. A different harness or an adapter may be necessary. These should be installed only by trained service technicians. Never use any harness or adapter that is not specified by the tow vehicle manufacturer and Cobalt Trailers.

**WARNING**

**As part of the hitching process, late-model tow vehicles are usually equipped with a sensor that reports when the trailer lights have been connected to the tow vehicle's connector. However, the LED lights utilized on Cobalt trailers sometimes do not pull a sufficient load on the tow vehicle's electrical system to register. This situation can be remedied by the tow vehicle's dealership.**

**CAUTION**

**Cobalt trailers require a seven-pin connector. Some older tow vehicles may have a five-pin connector instead of a seven-pin connector. An adapter is available through the tow vehicle's manufacturer. This is required to allow the back-up lights and solenoid to operate correctly. Failure to ensure that the entire lighting system on the trailer is operating correctly can mean that other vehicles following or in the vicinity of your tow equipment may not be alerted when you shift into reverse. This could lead to vehicle damage or injury.**

The trailer is equipped with running lights as well as taillights, stoplights, and optional landing lights. As specified by Cobalt, the lights have a very long lifetime, but if any ever cease to work, take the trailer to the nearest authorized Cobalt Trailer dealer to have the light repaired. If the exterior lens cover is damaged or broken, the entire one-piece unit will need to be replaced.

Additionally, these tips can help keep the light system working at its best:

- Check for properly operating lights prior to each use.
- Use a small amount of marine-grade electrical grease on the plug contacts and light-bulb base to prevent rust and corrosion.
- Be sure the ground wire (white) at the tongue is properly connected to the harness at all times.

If your trailer is equipped with the optional landing lights, be sure that the landing lights are off when operating the trailer on highways and public roads. In some jurisdictions, operation of the landing lights over the road is illegal.



## Axles

The trailer is equipped with the VAULT™ bearing protector. The VAULT uses only UFP Hybrid Oil™ lubri-

cant, which combines the benefits of oil and grease. The VAULT protects the wheel bearings in a sealed, pressurized chamber that is unaffected by outside elements. For optimal performance, only UFP's Hybrid Oil lubricant should be used in this system.

The system has several unique features not found on conventional trailer axles. Every possible leak point on the front and rear of the hub is sealed. (The slight pressure inside the hub is needed to keep water out of the hub chamber when the hub is submerged underwater during loading and unloading).

**Inspection or replenishment of the lubricant is not required as part of the routine maintenance for the first five (5) years.**

**NOTICE**

**Adding or changing the lubricant in the VAULT system is neither necessary nor recommended during the first five (5) years of service. After that time, the maintenance requirements should be undertaken only by an authorized Cobalt dealer and only the UFP's Hybrid Oil Lubricant should be used.**

If the bearings need to be adjusted or replaced, the work should be done only by an authorized Cobalt Trailer dealer. **Failure to contact Cobalt for preapproval during the warranty period will void the warranty.**

The wheel bearings have been precisely torqued at the factory. To assure the bearings are in good working order, check the bearing adjustment at least once a year by following this procedure:

- Jack up one side of the trailer. (Be certain to use jack stands and chock the trailer wheels to keep the trailer from moving during the inspection.)
- Grip the edge of the tire and see if it can be rocked or moved.
- If the outer edge of the tire moves more than 1/8", the bearings may need to be readjusted.
- A slight amount of oil seepage at the rear seal is normal and necessary to lubricate the wiper lip of the seal for long life. If excessive leakage is occurring, however, contact an authorized Cobalt trailer dealer.



## Wheels and Hubs

Because the wheels and hubs will be submerged in water at times, they require more attention than those found on a tow vehicle. Wheels should be regularly washed with mild soap or detergent to retain the finish and remove any corrosive elements. Never use harsh detergent or scrub brushes that can damage the appearance.

If your boat is stored in an area that experiences snow or ice, Cobalt highly recommends periodically checking and cleaning your wheels during the winter. Even following inclement winter weather, salt and chemical treatments used to remove snow and ice from roads and parking lots can settle on the wheels and cause damage to the finish. Such damage is not covered under warranty.



## Lug Nuts

Prior to each outing, check that the lug nuts have retained the correct torque. It is critical to use the correctly sized wrench when tightening or loosening lug nuts. (At present, Cobalt is using  $\frac{3}{4}$ " lug nuts on all trailers.) The wrong size wrench can cause the lug nuts to become rounded off, which can make them impossible to use.

**Never tow a trailer with a missing lug nut or lug nuts.** Having the complete number of lug nuts, properly torqued, is critical for both long-term use of the product and for road safety. Even one fewer lug nut can apply stress to the remaining lug nuts and the hub, which could result in failure.

Do not replace lug nuts, even missing ones, with lug nuts other than those available through an authorized Cobalt Trailer dealer. **The lug nut seat angle must match the wheel seat angle.** The assembly uses a specified lug nut selected for the kind of use the trailer will need. Even if the threads match, unapproved lug nuts may not hold the wheel securely enough. Lug nuts on each wheel should always match.

The torque applied when securing the lug nuts is also extremely important. If it is under-tightened, a lug nut can work loose under operation and come off. An over-tightened lug nut can strip the threads and come off.



**Check the lug nut torque after the first fifty (50) miles of trailer use. Then the lug nut torque should be checked every month afterwards that the trailer is used, and always checked prior to use if the trailer has been in storage or not used for a period of at least two weeks. Failure to do so could result in lug nuts loosening or dislodging from the wheel assembly. Such activity can have catastrophic results, including loss of tow vehicle and/or trailer control, which could result in serious injury or death.**



Lug nuts must also be correctly sized and specified for each trailer wheel. Failure to properly install and maintain the lug nuts could result in the trailer wheel coming off during operation. Such failure can result in serious injury or death, as well as property damage.

Follow these instructions for ensuring proper installation and torque for the lug nuts:

- **Use a torque wrench.** No other wrenches or similar tools are appropriate for use, except in an emergency.
- **Keep a record of readings.** If a lug nut or nuts routinely loses torque, it is symptomatic of a bigger problem that should be brought to the attention of your authorized Cobalt Trailer dealer to remedy.
- **Use this pattern to tighten lug nuts:** On the first round, tighten to 45 ft. lbs. Tighten a second time to 70 ft. lbs. Tighten again to 90 ft. lbs. And on the final time, tighten to 120 ft. lbs. Do this in a star pattern; do not simply go around clockwise or counter-clockwise. The cross effort will ensure a correct reading.

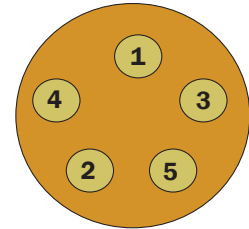

## Tires

Always keep tires to the specified inflation. The tire manufacturers will indicate the proper air pressure on the sidewall of the tire; this information is also available on the tire manufacturer's website.

Be sure to have a spare tire on all outings. Even new tires can be damaged or lose air.



**Follow the tire manufacturer's requirements to properly maintain tires. Failure to do so will cause tire failure while in use. This will result in loss of control of the trailer, which can lead to serious injury or death.**

When storing the trailer, periodically check the tire inflation. Loss of inflation can signal a problem and can shorten the duration of the tire's life. Also shield tires from UV rays, which can significantly damage rubber. If it is possible to support the trailer frame during storage with jack stands or concrete blocks, this can help lengthen the life of the trailer's springs on trailers so equipped, as well as relieving pressure on the tires.

Although the tires selected for the Cobalt trailer are durable, eventually they will require replacement. **DO NOT mix radial and bias-ply tires. This could affect handling and, ultimately, safety. Be certain that the replacement tires meet the trailer requirements and integrate with the remaining tires.**

The following information provided about tires is presented courtesy of the National Highway Transportation & Safety Administration. (Reprinted by permission.)



### **Tire Safety: Everything Runs On It**

Studies of tire safety show that maintaining proper tire pressure, observing tire and vehicle load limits (not carrying more weight by your vehicle than your tires or vehicle can safely handle), avoiding road hazards, and inspecting tires for cuts, slashes, and other irregularities are the most important things you can do to avoid tire failure, such as tread separation or blowout and flat tires. These actions, along with other care and maintenance activities, can also:

- Improve vehicle handling.
- Help protect you and others from avoidable breakdowns and accidents.
- Improve fuel economy.
- Increase the life of your tires.

The following section presents a comprehensive overview of tire safety, including information on the following topics:

- Basic tire maintenance.
- Uniform Tire Quality Grading System.
- Fundamental characteristics of tires.
- Tire safety tips.

Use this information to make certain tire safety is a regular part of your vehicle maintenance routine. Recognize that the time you spend is minimal compared with the inconvenience and safety consequences of a flat tire or other tire failure.

### **Safety First—Basic Tire Maintenance**

Properly maintained tires improve the steering, stopping, traction, and load-carrying capability of your vehicle. Underinflated tires and overloaded vehicles are a major cause of tire failure. Therefore, as mentioned above, to avoid flat tires and other types of tire failure, you should maintain proper tire pressure, observe tire and vehicle load limits, avoid road hazards, and regularly inspect your tires.

### **Finding Your Vehicle's Recommended Tire Pressure and Load Limits**

Tire information placards and vehicle certification labels contain information on tires and load limits. These labels indicate the vehicle manufacturer's information including:

- Recommended tire size.
- Recommended tire inflation pressure.
- Gross Vehicle Weight Rating (GVWR—the maximum occupant and cargo weight a vehicle is designed to carry).
- The gross axle weight rating (GAWR—the maximum weight each axle is designed to carry).

Both placards and certification labels are affixed to the trailer. The recommended tire pressure is on the tire, and the tire pressure and load limit appear on the trailer label.

### **Understanding Tire Pressure and Load Limits**

Tire inflation pressure is the level of air in the tire that provides it with load-carrying capacity and affects the overall performance of the trailer. The tire inflation pressure is a number that indicates the amount of air pressure—measured in pounds per square inch (PSI)—a tire requires to be properly inflated.

The proper tire pressure for the trailer is referred to as the “recommended cold inflation pressure.” As you will read below, it is difficult to obtain the recommended tire pressure if your tires are not cold.

Because tires are designed to be used on more than one type of vehicle, tire manufacturers list the “maximum permissible inflation pressure” on the tire sidewall. This number is the greatest amount of air pressure that should ever be put in the tire under normal driving conditions.

### **Checking Tire Pressure**

It is important to check your trailer's tire pressure at least once a month or every 50 miles, whichever comes first, for the following reasons:

- Most tires may naturally lose air over time.
- Tires can lose air suddenly if you drive over a pothole or other object or if you strike the curb when parking.
- With radial tires, it is usually not possible to determine under-inflation by visual inspection.

For convenience, purchase a tire pressure gauge to keep in your tow vehicle. Gauges can be purchased at tire dealerships, auto supply stores, and other retail outlets.

The recommended tire inflation pressure that manufacturers provide reflects the proper psi when a tire is cold. The term “cold” does not relate to the outside temperature. Rather, a cold tire is one that has not been driven on for at least three (3) hours. When you drive, your tires get warmer, causing the air pressure within them to increase. Therefore, to get an accurate tire pressure reading, you must measure tire pressure when the tires are cold or compensate for the extra pressure in warm tires.

### **Steps for Maintaining Proper Tire Pressure**

Step 1: Locate the recommended tire pressure on the trailer label.

Step 2: Record the tire pressure of all tires.

Step 3: If the tire pressure is too high in any of the tires, slowly release air by gently pressing on the tire valve stem with the edge of your tire gauge until you get to the correct pressure.

Step 4: If the tire pressure is too low, note the difference between the measured tire pressure and the correct tire pressure. These “missing” pounds of pressure are what you will need to add.

Step 5: Add the missing pounds of air pressure to each tire that is under-inflated.

Step 6: Check all the tires to make sure they have the same air pressure.

If you have been towing your trailer and think that a tire is under-inflated, fill it to the recommended cold inflation pressure indicated on your trailer label. While your tire may still be slightly under-inflated due to the extra pounds of pressure in the warm tire, it is safer to drive with air pressure that is slightly lower than the vehicle manufacturer's recommended cold inflation pressure than to drive with a significantly under-inflated tire. Since this is a temporary fix, don't forget to recheck and adjust the tire's pressure when you can obtain a cold reading.

### **Tire Size**

To maintain tire safety, purchase new tires that are the same size as the trailer's original tires, or another size recommended by the manufacturer. At present, the trailer manufacturer is not recommending any size differential than was originally equipped. If you have any doubt about the correct size to choose, consult your authorized Cobalt Trailer dealer.

### **Tire Tread**

The tire tread provides the gripping action and traction that prevent your vehicle from slipping or sliding, especially when the road is wet or icy in general. Tires are not safe and should be replaced when the tread is worn down to 1/16". Tires have built-in tread wear indicators that let you know when it is time to replace your tires. These indicators are raised sections spaced intermittently in the bottom of the tread grooves. When they appear even with the outside of the tread, it is time to replace your tires. Another method for checking tread depth is to place a penny in the tread with Lincoln's head upside down and facing you. If you can see the top of Lincoln's head, you are ready for new tires.

### **Tire Balance**

To avoid vibration or shaking of the vehicle when a tire rotates, the tire must be properly balanced. This balance is achieved by positioning weights on the wheel to counterbalance heavy spots on the wheel and tire assembly.

### **Tire Repair**

The proper repair of a punctured tire requires a plug for the hole and a patch for the area inside the tire that surrounds the puncture hole. Punctures through the tread can be repaired if they are not too large, but punctures to the sidewall should not be repaired. Tires must be removed from the rim to be properly inspected before being plugged and patched.

### **Tire Rotation**

Rotating tires from front to back and from side to side can reduce irregular wear (for vehicles that have tires that are all the same size). The generally recommended rotation period is every 5,000 miles.

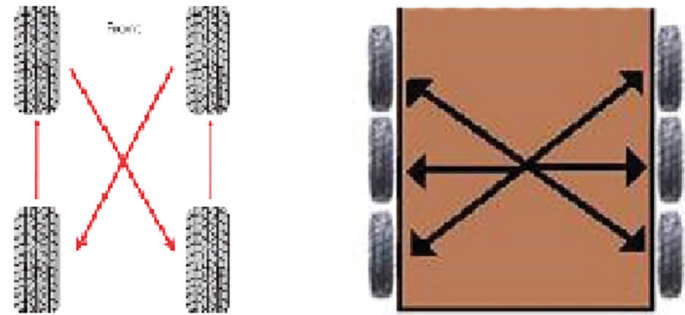

### **Uniform Tire Quality Grading System (UTQGS)**

To help consumers compare tread wear rate, traction performance and temperature resistance, the federal government requires tire manufacturers to grade tires in these three areas. This grading system, known as the Uniform Tire Quality Grading System (UTQGS), provides guidelines for making relative comparisons when purchasing new tires. You also can use this information to inquire about the quality of tires placed on new vehicles.

Although this rating system is very helpful when buying new tires, it is not a safety rating or guarantee of how well a tire will perform or how long it will last. Other factors such as personal driving style, type of vehicle, quality of the roads, and tire maintenance habits have a significant influence on your tire's performance and longevity.

Tread wear grades are an indication of a tire's relative wear rate. The higher the tread wear number is, the longer it should take for the tread to wear down. For example, a tire grade of 400 should wear twice as long as a tire grade of 200.

Traction grades are an indication of a tire's ability to stop on wet pavement. A higher graded tire should allow you to stop on wet roads in a shorter distance than a tire with a lower grade. Traction is graded from the highest to lowest as AA, A, B, or C.

Temperature grades are an indication of a tire's resistance to heat. Sustained high temperature (for example, driving long distances in hot weather), can cause a tire to deteriorate, leading to blowouts and tread separation. From highest to lowest, a tire's resistance to heat is graded as A, B, or C.

### **Tire Fundamentals**

Federal law requires tire manufacturers to place standardized information on the sidewall of all tires. This information identifies and describes the fundamental characteristics of the tire and also provides a tire identification number for

safety standard certification and in case of a recall.

### Information on Trailer Tires

Please refer to the following photo:



**ST:** The ST indicates that the tire is for trailer use.

**Next number:** This three-digit number gives the width in millimeters of the tire from sidewall edge to sidewall edge. In general, the larger the number, the wider the tire.

**Next number:** This two-digit number, known as the aspect ratio, gives the tire's ratio of height to width. Numbers of 70 or lower indicate a short sidewall for improved steering response and better overall handling on dry pavement.

**R:** The R stands for radial. Radial ply construction of tires has been the industry standard for the past 20 years.

**Next number:** This two-digit number is the wheel or rim diameter in inches. If you change your wheel size, you will have to purchase new tires to match the new wheel diameter.

### Tire Safety Tips

#### Preventing tire damage:

- Slow down when crossing over a pothole or other object in the road.
- Do not run over curbs or other foreign objects in the roadway and try not to strike the curb when parking.

#### Tire Safety Checklist

- Check tire pressure regularly (at least once a month or every 50 miles, whichever comes first), including the spare tire.
- Inspect tires for uneven wear patterns on the tread, cracks, foreign objects or other signs of wear or trauma.
- Remove bits of glass and other foreign objects wedged in the tread.
- Make sure your tire valves have valve caps.
- Check tire pressure before going on a long trip.
- Do not overload your vehicle. Check the tire information placard for the maximum recommended load for the vehicle.
- When towing the trailer, remember that some of the weight of the loaded trailer is transferred to the towing vehicle.

- For more information, visit [www.nhtsa.gov](http://www.nhtsa.gov) or call (888) 327-4326.



### Brakes

Most Cobalt trailer brakes are “surge” brakes, which can be effective and helpful particularly when towing heavy loads. (**NOTE:** Not every jurisdiction allows surge brakes. Check with authorities in the area in which you will be towing.) Trailers may be equipped with optional electric brakes instead. Information follows regarding that type of braking system.

When the tow vehicle slows or stops, the trailer's momentum moves against the hitch ball and causes hydraulic pressure in the master cylinder (located in the trailer's tongue) to transfer pressure through the brake lines, causing the brakes to engage.

The trailer brakes should always be maintained in top condition. This includes regularly checking the fluid level in the actuator. The loss of brake function can result in loss of control or the inability to stop the trailer, which could lead to serious injury or death.

See the information provided in this section of the manual about the breakaway cable. The breakaway cable should **NEVER** be used as a substitute for braking or as a parking brake.



**Note that if the breakaway cable has been engaged—even slightly, as can happen when the trailer is disengaged from the tow vehicle and the cable is tripped over—it can cause the cable clip to break. If the cable clip is missing, or it has been broken, first check and attempt to release the emergency brake mechanism by pressing up on the brake release tab under the actuator nose, right behind the tow ball insert location. Press up on the brake release tab, and if a metallic clunk or sound of spring releasing is heard, that means the emergency brake mechanism had previously been engaged. When pressing up on the brake release tab, if it moves up and down freely with just the resistance of its spring, then the emergency brake system was likely not previously engaged. If the cable clip is broken or missing, the breakaway cable cannot operate properly. Such failure could result in serious injury or death.**



**The photo shows a broken cable clip.**

Note that brakes will be submerged when the trailer is backed into the body of water to unload or load the boat. If the brakes (and/or wheels) are hot, it is recommended to wait briefly and allow them to cool before submerging.

Excessive heat in the wheels as a result of road use, meeting cooler water can cause damage to the components, especially the calipers and rotors. Also, if the trailer is submerged in salt or brackish water, be sure to carefully and completely rinse the entire trailer after the outing. Salt and exceptionally dirty fresh water can cause damage to the trailer components, which is not covered under warranty.

## NOTICE

**Salt and brackish fresh water can damage trailer components, which is not covered under warranty. Always clean the trailer with a freshwater rinse and/or use of mild soap after an outing in which parts of the trailer have been submerged.**

Regarding routine maintenance, you need to be aware that small amounts of rust will build up on the brake's rotor surface if the trailer sits for a fairly short period of time, as little as a week. The brake's pads will eliminate the rust after several applications of braking, but if the trailer has been sitting for a more-extended period of time, and especially following long-term storage such as over the winter off-season, the brakes may be significantly corroded. This can also happen if the trailer has been submerged in salt water and has not been sufficiently rinsed with fresh water afterwards. Greater concentrations of rust may require assistance from your authorized Cobalt Trailer dealer to ensure ongoing proper functionality.

If there is any concern about the condition of any component of the braking system, have an authorized Cobalt trailer dealer review and rectify the matter before towing the boat.

### **How to Manually Bleed the Brakes**

**Because of the importance of correctly performing this procedure, Cobalt strongly recommends that this be done only by trained service technicians at your authorized Cobalt Trailer dealer.** However, recognizing that brake issues arise and may have to be addressed in situations in which the trailer cannot be taken to the dealer for repair, the following instructions are provided with the understanding that they should be utilized only in emergency.

- Check that all hydraulic fittings are secure.
- Read and understand all instructions before starting.
- Two people are required for manual bleeding.

**Step 1:** Remove the master cylinder reservoir plug and fill the reservoir with brake fluid, being careful not to spill any fluid on the paint as it will cause damage.

a. DOT 3 Premium is the preferred automotive brake fluid. Follow the instructions on the brake fluid container.

b. Avoid shaking the brake fluid container and pour fluid slowly to minimize air entrapment.

c. Let the fluid in the reservoir stand until it is completely free of air bubbles.

**Step 2: IMPORTANT: Before bleeding the brake lines, bleed the actuator master cylinder.** Insert a screwdriver through the hole in the bottom of the inner member and use short strokes to pry on the push rod (while holding the safety release bracket up) until no air bubbles are seen coming from the small orifice hole in the bottom of the master cylinder reservoir.

**Step 3:** Start the bleeding procedure on the brake farthest from the master cylinder.

**Step 4:** At the brake assembly, connect a transparent bleeder hose to the bleed screw fitting on the wheel cylinder and submerge the free end into a container partially filled with brake fluid. *Do not reuse this fluid.*

**Step 5:** The first person should stroke the push rod slowly while holding the safety release bracket up.

**Step 6:** The second person opens the bleed screw fitting.

**Step 7:** Then close the bleed screw fitting **before** the first person **slowly** releases the push rod.

**Step 8:** Repeat this procedure until the fluid expelled from the bleeder hose is free of air bubbles.

**Step 9:** Remember to always tighten the bleeder screw before releasing the push rod. During this procedure, the master cylinder reservoir fluid level must be maintained at no less than half full.

**Step 10:** Repeat Steps 4-9 for the other brake, as well as the brakes on the front axle of tandem or triple axles.

**Step 11:** If installation is on a tandem-axle or triple-axle trailer, repeat the bleeding procedure on the rear axle brakes for a second time to assure purging of all air in the system.

**Step 12:** As a final check after bleeding is completed, stroke the push rod and check to be sure the brake system is pressurized. This is done by attempting to rotate a tire around.

**Step 13:** Push up on the safety release bracket to ensure that the push rod is in the released position.

**Step 14:** After the bleeding is completed, recheck the fluid level in the master cylinder. Fill the master cylinder reservoir to the indicator on the reservoir plug. Do not overfill.

### **Optional Electrical Brakes**

As an option, Cobalt offers electrical brakes. The system

uses electric power from the towing vehicle to drive the hydraulic power source. In a breakaway situation, the electric power is supplied by a breakaway battery connected to the towed vehicle brake actuation system. This battery is charged by a charger built into the control circuitry.

The actuator reacts in one of three ways: primarily, it turns on when the brake pedal of the towing vehicle is depressed. If due to road conditions it is desirable to apply only the towed vehicle brakes, this is achieved by applying the manual override on the in-cab brake controller. In a breakaway situation, the towed vehicle braking system is applied by the breakaway switch, which is explained elsewhere in this section of the manual.

The system requires an in-cab electric brake control not provided as part of the system. The system will operate from most electric brake controllers **when properly installed**.

Proper electrical wiring is **critical** for the performance of the braking system. Improper wiring can result in damage to the actuation system or system failure after initial use. A pure ground and direct power (+12 VDC) with fuse or circuit breaker (30 amp) are necessary to ensure good performance. Line losses and poor grounding will result in poor performance or total loss of towed vehicle braking. The connection for the system is provided by prewired harnesses, and the plug connectors are keyed so that they cannot be connected incorrectly. However, if the plug between the towing and towed vehicles is not wired properly, the unit will either not function at all or will function improperly.

#### **When Towed by 2006 Mid-Year or Later Ford, Chevy, GMC Truck Equipped with a Factory Brake Controller**

Any Cobalt trailer with the electric over-hydraulic brake system installed and towed by a 2006 mid-year or later Ford, Chevy or GMC truck may experience towing issues if the truck is equipped with an optional factory-integrated trailer brake controller.

These trailer brake controller systems are intended to assist with the trailer braking process. Because of the way these systems are designed, however, they can prevent the electric trailer braking system from engaging as intended. **This is NOT a malfunction of the Cobalt trailer.**

New in model year 2021 was an electric over-hydraulic brake system equipped with an adapter for 2006 mid-year or newer Ford and Chevy factory-integrated trailer brake controllers. If you have a newer model year vehicle, test the brakes before leaving the dealership. If the brakes are not working correctly, it takes only a matter of minutes to plug in the adapter.



**The trailer brakes should always be maintained in top condition. This includes checking the fluid level in the**

**actuator regularly. The actuator access location is via a cap on top of the trailer tongue. The loss of brake function can result in loss of control or the inability to stop the trailer, which could lead to serious injury or death.**

- The breakaway cable should **NEVER** be used as a substitute for braking or as a parking brake.
- Periodic inspection should be made of the electrical connector, wiring, brake lines, and hose for the entire brake system to ensure there are no abraded or bare wires, damaged steel lines, or cracked and damaged hoses. During inspection verify that there are no loose or hanging lines or wire that might drag or catch on objects/debris while being towed.

If there is any concern about the condition of any component of the braking system, have an authorized Cobalt trailer dealer review and rectify the matter before towing the boat.

Prior to **EACH** towing:

- Check the fluid level in the reservoir on the trailer frame. The fluid level must be maintained with 3/8" to 1/2" below the filler opening. If brake fluid is needed, add only new, clean DOT3 Premium Brake Fluid. Use caution when removing the filler cap to prevent the introduction of dirt and/or contaminants into the fluid reservoir.



**Do not use brake fluid drained from the brake system to refill the master cylinder reservoir as such fluids contain contaminants from the system that may result in brake failure or costly repairs.**

- Check to be certain the breakaway battery is charged and that the breakaway works. This is accomplished by pulling the cable on the breakaway switch. If the vehicle has been parked for extended periods of time, the breakaway battery may be discharged. If that occurs, charge the breakaway battery in accordance with the manufacturer's recommendations prior to operation. If the battery is allowed to discharge in a cold environment there is a possibility of freezing, which could cause damage to the battery. Such damage may not be covered by warranty.
- Again, use caution when handling brake fluid as spilled fluid will damage paint.



**Appropriate installation, maintenance, and repair procedures are essential for the safe, reliable operation of vehicle brakes. Anyone who undertakes to maintain or repair vehicle braking systems must establish that they neither compromise their personal safety nor the vehicle integrity by their choice of methods, tools, or parts.**

# TOWING ADVICE

## Prior to Towing

- Be certain that you have a jack and lug wrench that will work on the tow vehicle and the trailer. The same ones may not work on both, so verify that you are prepared. You don't want to end up on the side of the road and find that you are not fully prepared.
- In addition to the spare tire that can be mounted on the trailer spare tire mount, also have available in your tow vehicle's storage area such useful additional items as:
  - Extra lug nuts;
  - Wheel chocks (especially important in areas in which
    - there are hilly or mountainous driving conditions).

The wheel chocks are also offered as a hidden wheel chock option;

- Wheel bearing grease;
- Marine grade grease;
- Spare tie-down straps;
- Additional brake fluid for the actuator;
- A torque wrench to check and ensure the lug nuts are properly torqued;
- Road flares.



## Pre-Tow Check List

- Verify the coupler, hitch, and hitch ball are the correct, specified size and fit.
- Be certain the safety cables and breakaway cable are correctly attached.
- Check that tie-downs and the winch strap are secure.
- The wheel lug nuts are properly torqued.
- The tires are inflated to the air pressure level stamped on the sidewall.
- The trailer lights are operating properly.
- The brakes are functioning as designed.
- If the boat is equipped with a tower, it must be either upright and locked, or lowered and secured. If the tower is upright, you will need to determine that the total height of boat, trailer, and tower will be able to clear power lines, bridges, overpasses, or any other impediment.
- The total load does not exceed the GVWR.



## Underway

Towing is more challenging than driving down the road in a single vehicle. Therefore, you would be well-advised to practice before undertaking a genuine tow to a body of water for an outing.

**Cobalt cannot anticipate every possibility that will arise and assumes no responsibility for the operation of your tow vehicle and/or trailer, but the following are some recommendations that can enhance the towing experience and better prepare drivers:**

**Drive sensibly.** You will have a substantially greater length and weight to maneuver. This means you need more time and space to accelerate or to stop. Weather conditions are amplified. Wind especially can create more challenges in maintaining control.

**Use those mirrors.** Most tow vehicle manufacturers recommend adding oversized mirrors. Some legal jurisdictions require it. Regardless, the better you are able to see, the more control over the total rig you'll have. Larger mirrors can also assist you in keeping an eye on the trailer and boat to be aware of how well they are moving down the road.

**Allow extra room when making turns.** You will quickly learn that turns, especially right turns, take more space. You've seen this with tractor-trailer units and other tow vehicles.

**Think twice and allow extra room when passing other vehicles.** It will take longer to accelerate to passing speed, and you will need considerably more room when moving back into the driving lane. Passing on grades is not recommended as it is more difficult to maintain overall control. It may be necessary to downshift gears in the tow vehicle when passing, too. Avoid road shoulders, especially narrow ones. If you go off the paved surface, especially at highway speed, you may lose control or even jackknife the rig.

**Use common sense.** All the potential issues that cause potential problems when driving a regular highway vehicle are exaggerated when towing. Avoid tailgating, jack rabbit starts and stops, or any maneuver that exceeds the capabilities of your rig. Any time your rig fish-tails, stop and determine what the cause is. Often it is shifting weight, particularly within the boat or on the trailer. Readjusting the towed items may take a few minutes but can save your life and others'.

# LAUNCHING AND RELOADING THE BOAT FROM THE TRAILER

Releasing the boat from the trailer requires skill as well. Conditions may vary from location to location, too. It is important to pay attention to surroundings and plan the release to avoid damage to the boat, trailer, and dock/ramp. See the information in this section of the manual regarding the optional depth alarm. That functionality can make loading/unloading your boat considerably easier.

For boats not equipped with the depth alarm, you should first examine the ramp. Some are unimproved while others are paved, and many are something in-between. You will also need to know the ramp's steepness as that affects how far you will need to back the trailer into the water. You need confidence that the ramp surface will support the weight of the trailer and boat as you ease back, and that you will not bog down in the water or on the land surface. Sufficient width, especially if you are inexperienced in backing up, is important, too. Consider that the land may also be slippery if wet, which can affect control over the rig.

Before backing into the water, double-check that your boat is ready for launch. This includes ensuring that the drain plugs are installed on the boat to avoid swamping and potentially flooding it.

Then you should release the tie-downs except the winch.

Slowly back the trailer and boat into the water. If possible, have a second person standing by (but never directly in back of the rig) to help guide you. When backing up, note that the trailer will go in the opposite direction to the direction in which the tow vehicle steering wheel is turned.

Back up in the water until the front fender is about 4" underwater for a single-axle trailer. For a tandem-axle trailer back up until the front fender is approximately 2" under water. For triple-axle trailers you'll back up until the front fender is about 2" out of the water.

Place the tow vehicle in Park (or a forward gear if the tow vehicle has a manual transmission) and shut off the tow vehicle engine. Set the parking brake.

After checking that the water depth is sufficient for your boat's hull (it should not contact the ramp surface or ground underwater), release the trailer winch latch-and-hook. When all tie-downs are released, back the boat into the water and secure to a dock as described

elsewhere in this manual or anchor while you remove the tow vehicle and trailer from the ramp.

To reload at the conclusion of your outing, reverse the process. When the trailer is in position, verify that the trailer bunks on which the boat will rest are free of dirt, sand, or other debris that could scratch the boat hull. It is a good idea to back the trailer sufficiently to wet the trailer bunks completely as this will add to protection for the hull when the boat is loaded.

Directions and suggestions for driving the boat onto the trailer are provided elsewhere in this manual. This requires practice to master, but correctly loading the boat is critical for both safety and protection of the condition of the boat and trailer.

Be sure that the tie-downs are secure prior to towing.

## CAUTION

**Submerging part of the trailer in water will cause the brakes to be wet. See the *Brake* information in this section of the manual regarding care following an outing. Also, be aware that while the brakes are wet, they will not work as quickly or efficiently as normal. As soon as they dry, the brakes should resume their normal characteristics.**



## Cleaning, Maintenance, and Storage

Proper cleaning, including corrosion prevention, and maintenance are critical to ensuring the long life of your Cobalt trailer. That information, along with requirements for storage (periods of time exceeding a week) are found in the Care and Maintenance section of this manual.

Please carefully review that information and follow it throughout the time of trailer ownership. Note that failure to follow the care and maintenance procedures as described in the *Care and Maintenance* section of this manual can result in damage to the trailer that could cause component failure over time. Damage due to neglect is not covered under warranty. It can also result in trailer failure that could potentially cause serious injury or death, not only to those in the tow vehicle but also to others on the road in the vicinity.

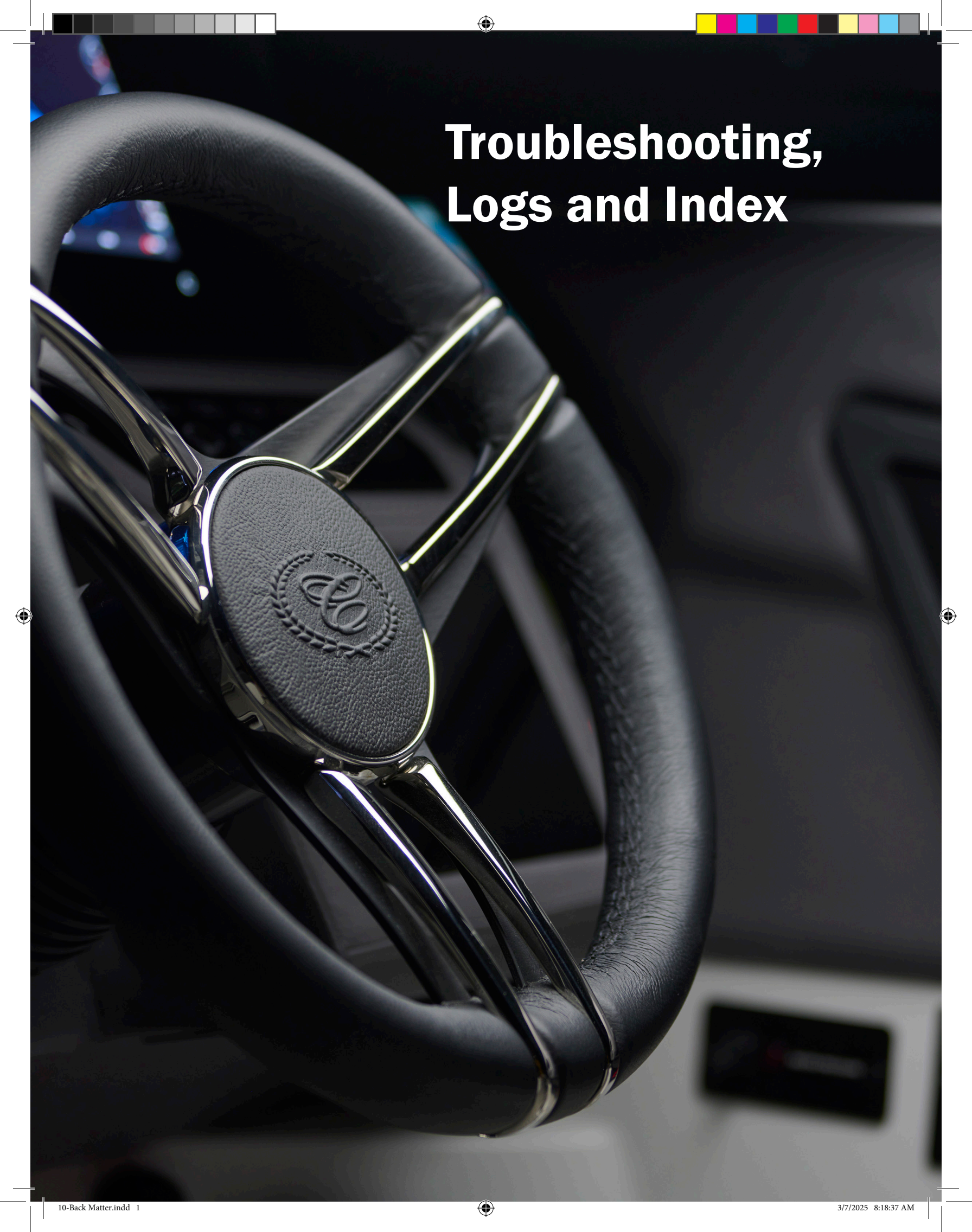

# Troubleshooting, Logs and Index

# TROUBLESHOOTING

If any of the following issues cannot be rectified by using the suggested remedies, take the boat to an authorized Cobalt dealer for assistance. **Do not attempt to correct problems by methods not recommended in this troubleshooting guide.** Utilizing other attempts to correct issues could result in additional problems or damage to a system, which would not be covered under warranty.

## DANGER

**Handle fuel and fuel elements such as the fuel pumps and fuel lines with extreme care. Fuel is flammable. Fumes are even more flammable and dangerous. Never have open flame in the region of any part of the fueling system.**

## DANGER

**Electrical system malfunctions can cause shock hazards, which can be serious, even fatal. Always check for electrical activity prior to attempting to troubleshoot or correct any part of the electrical system.**

## CAUTION

**Battery acid can cause serious injury, particularly to the eyes and skin. Avoid contact, but if it occurs, be sure to flush contact areas with copious amounts of water and seek immediate medical attention.**

## CAUTION

**Disconnect the battery cables at the battery before checking or adjusting engine and electrical components.**



## General

### Issue:

The boat will not start.

### Consider:

- Verify that the battery switch is ON.
- Verify that the battery is fully charged and the battery connections are secure.
- For outboards, check that the starter connections are tight. If the solenoid clicks when attempting to start the engine, check the battery connections. If the condition persists, see an authorized Cobalt dealer.
- Be certain the Emergency Safety Stop Switch is attached to the connection point on the driver's panel and to the boat operator.
- Be sure that the shifter/throttle device is in the neutral position.
- Be certain the engine electrical system is ON. Generally, this requires turning the ignition key ON or pressing the ON button.
- Verify the engine circuit breaker has not tripped.

- It is possible the display is in a "sleep" mode. Press a key or touch the screen to see if the affected display activates.
- Refer to the propulsion unit owner's manual.
- If the engine turns over but will not start, check the fuel system, i.e., that fuel valves are open or if the fuel may be contaminated (more likely when the fuel has been sitting in the tank for an extended period of time).
- If none of these suggestions correct the situation, see an authorized Cobalt dealer.

### Issue:

The boat will not shift into gear.

### Consider:

- When engaging the transmission from neutral either forward or backward into reverse, pull up on the safety collar located directly below the throttle lever knob. The safety collar helps avoid unintentional movement into gear.
- When shifting gears, always do so smoothly and briskly. Being either too hard and slamming the gears, or too tentative is hard on the shifter/throttle system and can result in damage that is not covered under warranty.

### Issue:

The engine/drive train is not operating properly.

### Consider:

- Refer first to the propulsion unit owner's manual or the *Engine* section of this manual (for boats equipped with the Monsoon engine) for guidance.
- Check the fuel level in the boat to be certain that the engine is not "starving" from lack of fuel or contaminated fuel. Improper fuel can also affect performance.
- Check for engine warning messages on the gauges/display. If any are present, take the boat to the closest authorized Cobalt dealer for evaluation and repair.
- Improper loading, excessive weight on-board, boat rim, excessive bilge water and other issues can affect performance.
- If there was difficulty starting but the engine runs properly after it starts, the issue may be an insufficient battery response. Check with your authorized Cobalt dealer as to whether the battery needs attention or replacement. Use ONLY marine-grade batteries!

### Issue:

The engine and/or boat vibrates when running.

### Consider:

- The propeller may be bent, broken or damaged, throwing off the propulsion balance. Also, check for weeds tangled in the propeller or other debris that may require removal.



## Gauges, Switches and Video Screens

### Issue:

A gauge or video screen does not light up and work as expected.

### Consider:

- Be certain the engine electrical system is ON. Generally, this requires turning the ignition key ON or pressing the ON button.
- It is possible the display is in a “sleep” mode. Press a key or touch the screen to see if the affected display activates.
- Verify that the battery connections are secure.
- Determine if other gauges, switches and/or video screens are operational. If they are, check the circuit breaker panel to determine if the breaker has tripped. Reset. If the circuit continues to trip, the boat must be serviced by an authorized Cobalt dealer as it indicates a recurrent and potentially significant problem. Another cause is a loose electrical connection to the non-working gauge/switch/video screen. This matter should be addressed by an authorized Cobalt dealer.
- If a video screen freezes or displays an unreadable or invalid screen, turn the entire system OFF, including the engine electrical system. Allow a few minutes for the system to re-set itself, and then try rebooting the system. If the issue persists or another issue arises, take the boat to an authorized Cobalt dealer for correction. Where equipped, check the battery isolator switch.



## Electrical Systems

### Issue:

A boat component that is electrically operated will not operate.

### Consider:

- Be certain the boat electrical system is ON. Generally, this requires turning the ignition key ON.
- Verify that the battery connections are secure and that there is sufficient charge and power. See the *Battery* information in this manual for additional details.
- Verify that the circuit breaker has not tripped. If it has, clear the fault and reset it. Recurrent trips are indicative of a problem that requires the attention of an authorized Cobalt dealer.
- Check for loose connections, but do not remove any closeout panels to do so. If a loose connection is suspected but cannot be seen, have the system checked by an authorized Cobalt dealer.
- If the component is electronic, be certain the component is operational. If it requires reception from a satellite, tower or other supplier, Cobalt cannot guarantee that it will receive the signal. It may be necessary to move the boat to another location or body of water, or pay a subscription fee.



### Issue:

Accessories will not recharge in the 12-volt receptacle.

### Consider:

- Verify that the correct charger was used for the item(s) and that the charger plug-in was fully seated in the 12-volt receptacle.

### Issue:

Lights will not come on or are dim.

### Consider:

- Verify that the circuit breaker has not tripped. If it has, clear the fault and reset it. Recurrent trips are indicative of a problem that requires the attention of an authorized Cobalt dealer.

### Issue:

Generator (where equipped) will not start.

### Consider:

- Verify that the battery connections are secure and that there is sufficient charge and power. See the *Battery* information in this manual for additional details.
- Run through the various Electrical Systems potential solutions. If none of these work, seek attention from an authorized Cobalt dealer.

### Issue:

No AC power.

### Consider:

- Verify that the circuit breaker has not tripped. If it has, clear the fault and reset it. Recurrent trips are indicative of a problem that requires the attention of an authorized Cobalt dealer.
- Check that the ground fault circuit interrupter has not tripped. If suspected, reset the button on the outlet and test. If this persists, see an authorized Cobalt dealer.
- Be certain that the shore/generator selector switch is positioned correctly.

## Battery Failure

Often, a battery that will not start the boat requires recharging. Use **ONLY** a marine-approved battery charger. Any other can damage the electrical system, and such damage is not covered under warranty. **NEVER** attempt to “jump” from a vehicle or another boat as there is a potential for overload that could significantly damage the boat’s electrical system, which is not covered under warranty! Read the battery information provided in this manual before undertaking any attempt to replace, use both batteries simultaneously, or replace the battery.



## Alarms

### Issue:

The low voltage alarm sounds.

### Consider:

- Most often, this signals the need to turn OFF and leave OFF the stereo component or similar electronics that require substantial support from the batteries. Start the engine and allow the alternator to recharge the batteries, which will require a fairly short period of time if there is no additional drain occurring during the recharging time. If this does not work, it may be that the battery or batteries are nearing their terminal life span.

### Issue:

Another alarm sounds.

### Consider:

- These occur when a sensor detects that the engine or transmission temperature range or oil pressure range have exceeded programmed limits. The boat's main system may begin shutting off peripheral activity to retain proper operation as long as possible. It is usually in the operational best interest to return to shore as soon as possible to avoid being stranded. Even if the ranges return to acceptable operating range, this matter should be shared with the service department of your authorized Cobalt dealer to determine the cause and avoid a repeat.



## Bilge, Ballast and Plumbing

### Issue:

The bilge pumps are not operating.

### Consider:

- The bilge pump(s) should operate automatically. If it does not, use the manual switch. If it still does not operate, return to shore **IMMEDIATELY** and terminate the outing. See an authorized Cobalt dealer before the next outing to ensure the bilge pumps are working properly. Failure to pump water out of the bilge can result in the boat swamping. This could result in serious injury or death to those on-board.

### Issue:

The ballast pump is not operating.

### Consider:

- If the ballast pump does not pump water into the system, and having verified that the electrical system is operational, leave the pump OFF and have it serviced by an authorized Cobalt dealer. If the pump does not pump water out of the system, seek assistance by calling your Cobalt dealer. You should never attempt to tow your boat on a trailer with water in the ballast

system as it could cause damage to the trailer, which can result in the driver losing control while towing. Such activity could result in serious injury or death to anyone in the area.

- Additional information on the bilge and ballast systems can be found in this manual.

### Issue:

No water at the sink (where equipped).

### Consider:

- The fresh water pump circuit breaker may have tripped or be in the OFF position. Correct the issue and reset so that the breaker is in the ON position.
- Verify that there is water in the fresh water tank.
- The fresh water pump may be defective. See an authorized Cobalt dealer for correction.
- The filter may be plugged. Clean the filter, which is located at the tank, under the deck mid-berth.

### Issue:

Low water pressure at the sink.

### Consider:

- Most likely, either the fresh water pump is defective, or there is a restriction/obstruction in the water line. See an authorized Cobalt dealer for assistance.

### Issue:

The head (where equipped) will not flush.

### Consider:

- The head circuit breaker may have tripped or be in the OFF position. Correct the issue and reset so that the breaker is in the ON position.
- The line to the waste tank may be blocked. See an authorized Cobalt dealer for assistance.



## Blower System

### Issue:

The blower is not working.

### Consider:

- **Never operate the boat without the blower system operating correctly!** Accumulating fumes that are not released through the blower system can result in an explosion or other serious accident that could result in death to those on-board. If the blower ceases to work properly while boating is underway, terminate the outing **IMMEDIATELY** and return to shore with the engine compartment covers open. If there is an odor of fuel or exhaust present, turn OFF the engine **IMMEDIATELY** and seek a tow to shore. See the *Safety* section of this manual; additional details are also available in other sections of this manual.



## WARRANTY TRANSFER—BOAT

See the Warranty Statement previously detailed in this owner's manual. Read carefully to determine the appropriate circumstances under which existing and remaining warranty may be transferred to subsequent owners of the boat. In instances where warranty is transferable, complete this form and fax to (620) 325-2190, or mail to Cobalt Boats 1715 North 8th Street, Neodesha KS 66757.

Date: \_\_\_\_\_

Cobalt Boat Serial Number: \_\_\_\_\_

Original Owner (Seller): \_\_\_\_\_

Address: \_\_\_\_\_

\_\_\_\_\_

Home Phone: (\_\_\_\_\_) \_\_\_\_\_ Work Phone: (\_\_\_\_\_) \_\_\_\_\_

Email Address: \_\_\_\_\_

New Owner (Purchaser): \_\_\_\_\_

Address: \_\_\_\_\_

\_\_\_\_\_

Home Phone: (\_\_\_\_\_) \_\_\_\_\_ Work Phone: (\_\_\_\_\_) \_\_\_\_\_

Email Address: \_\_\_\_\_

Submitted by (Dealer): \_\_\_\_\_

Individual: \_\_\_\_\_

## WARRANTY TRANSFER—ENGINE AND/OR TRAILER

**Engine and trailer warranties are administered by the unit's manufacturer.** Refer to the owner's manual that came with the product for information about the warranty, its limitations and how to secure assistance for warranty issues. Those manuals will also indicate whether or to what extent a transfer may or may not be available.

For boats equipped with the Monsoon Engine or the Cobalt/Malibu Trailer, the warranty may be transferred from the original owner to a second private owner within

the first five (5) years of the original date of purchases **to the second owner only.**

- The warranty is not eligible to be transferred to a third owner for purpose of warranty coverage.
- The warranty is no longer eligible for transfer after five (5) years.
- The unit must be fully inspected by an authorized Cobalt dealer. The dealer will complete a warranty transfer specific to that unit. The transfer must be signed by the second private owner. The transfer forms are available through the dealership only.





# BOAT INFORMATION

Complete and store in a secure location other than the boat.

Owner \_\_\_\_\_

Home Port \_\_\_\_\_

Boat Name \_\_\_\_\_

Selling Dealer \_\_\_\_\_

Port Ignition Key Number \_\_\_\_\_ Starboard Ignition Key Number \_\_\_\_\_

Cabin Key Number \_\_\_\_\_

Registration Number \_\_\_\_\_ State \_\_\_\_\_

Hull Serial Number \_\_\_\_\_ Warranty Registration Date \_\_\_\_/\_\_\_\_/\_\_\_\_

Engine Make and Model Number \_\_\_\_\_

Engine Serial Number (where applicable) \_\_\_\_\_

Port Engine Serial Number \_\_\_\_\_ Stbd Engine Serial Number \_\_\_\_\_

Port Drive Serial Number \_\_\_\_\_ Stbd Engine Serial Number \_\_\_\_\_

Propeller Size \_\_\_\_\_

Generator Model Number \_\_\_\_\_

VHF Radio Make & Model Number \_\_\_\_\_ Serial No. \_\_\_\_\_

GPS Make & Model Number \_\_\_\_\_ Serial No. \_\_\_\_\_

Radar Make and Model Number \_\_\_\_\_ Serial No. \_\_\_\_\_

DVD Make and Model Number \_\_\_\_\_ Serial No. \_\_\_\_\_

Stereo Make and Model Number \_\_\_\_\_ Serial No. \_\_\_\_\_

TV, Cabin Make and Model Number \_\_\_\_\_ Serial No. \_\_\_\_\_

TV, Mid-berth Make and Model Number \_\_\_\_\_ Serial No. \_\_\_\_\_

Subwoofer Make and Model Number \_\_\_\_\_ Serial No. \_\_\_\_\_



# FLOAT PLAN

Copy this page and fill out the copy before an outing. Leave the completed copy with a reliable person who can be depended on to notify the USCG or other rescue organization if you do not return as scheduled. No not file this plan with the USCG.

Name \_\_\_\_\_

Telephone \_\_\_\_\_

Description of Boat: Type \_\_\_\_\_ Color \_\_\_\_\_ Trim \_\_\_\_\_

Registration Number \_\_\_\_\_ State \_\_\_\_\_

Length \_\_\_\_\_

Other Identifying Boat Info \_\_\_\_\_

Persons Aboard (Name, Age, Address & Phone)

\_\_\_\_\_  
\_\_\_\_\_  
\_\_\_\_\_  
\_\_\_\_\_  
\_\_\_\_\_

Engine Type \_\_\_\_\_ Horsepower \_\_\_\_\_

No. of Engines \_\_\_\_\_ Fuel Capacity \_\_\_\_\_

Survival Equipment:

PFDs \_\_\_\_\_ Flares \_\_\_\_\_ Mirror \_\_\_\_\_

Smoke Signals \_\_\_\_\_ Flashlight \_\_\_\_\_ Food \_\_\_\_\_

Paddles \_\_\_\_\_ Water \_\_\_\_\_ Anchor \_\_\_\_\_

Raft/Dinghy \_\_\_\_\_ EPIRB \_\_\_\_\_

Radio: Yes \_\_\_\_\_ No \_\_\_\_\_ Type \_\_\_\_\_ Frequency \_\_\_\_\_

Destination \_\_\_\_\_ Estimated Time of Arrival \_\_\_\_\_

Expected to Return by \_\_\_\_\_

Auto/Tow Vehicle \_\_\_\_\_ License No. \_\_\_\_\_

Parked Location \_\_\_\_\_

If not returned by \_\_\_\_\_, contact the Coast Guard or call

\_\_\_\_\_

Stereo Make and Model Number \_\_\_\_\_ Serial No. \_\_\_\_\_

(Local Authority), or Coast Guard Phone Number: \_\_\_\_\_





# SERVICE LOG

Service Performed	Date	Date	Date	
Oil Change, Including Replace Oil Filter				
Wax Exterior				
Thoroughly Clean Interior				
Replace Battery				
Charge or Replace Fire Suppression Equipment				
Check/Repair PFDs and Other Safety Equipment				
Check/Repair Engine Mounts				
Check/Repair Steering System				
Check/Repair Shift & Throttle System				
Inspect/Repair/Replace Ballast Pumps				
Inspect/Repair/Replace Bilge Pumps				
Replace Fuel Filter/Inspect Fuel Lines				
Check Hull Paint (where applied)				
Prepare for Storage/Winterization				
Recommission Boat				
Other				
Other				
Other				
Other				
Other				





# INDEX

100 Hours, Every.....	116	Bow Shade.....	93
50 Hours, Every.....	116	Bow Tonneau Cover.....	91
Accidents, Reporting.....	27	Brakes.....	166
Addendum A—Service Assist Service Agreement .....	123	Breakaway Cable.....	158
Additional Cleaning Advice .....	111	Breaker Panel, Circuit .....	65
Additional Precautions for Towed Skier/Rider .....	38	Break-In Period.....	148
Afloat, Staying.....	42	Break-In Procedure .....	148
After Each Use.....	116	Burdened Vessel .....	32
After Storage, Reactivating the Boat .....	119	Cabinetry and Wood.....	109
Aids to Navigation .....	34	Cable, Breakaway.....	158
Air Compressor.....	86	Cables, Safety .....	157
Alarms, Engine .....	73, 145	California Air Resources Board.....	29
Alarms (Troubleshooting).....	174	California Emissions Information .....	143
Aluminum Arch with Sunshade, Stainless Steel .....	92	California Evaporative Emissions Control System Warranty Statement.....	124
Aluminum Components, Stainless Steel and Chrome.....	102	Canvas and Covers.....	90
Amenities.....	7	Canvas Components, Other.....	109
Anchor Light.....	87	Canvas .....	108
Anodes, Galvanic Corrosion and Zinc.....	104	Capsizing .....	42
Arch with Awlgrip Topcoat, Stationary.....	112	Captain's Chair Adjustments and Operation .....	83
Arch with Bimini.....	92	Carbon Monoxide Safety.....	23
Arch with Bimini, Electric .....	92	Care and Cleaning of Vinyl.....	106
Arch with Sunshade, Black/White Electric or Folding.....	93	Care and Maintenance (Engine) .....	149
Arch with Sunshade, Stainless Steel/Aluminum .....	92	Care and Maintenance (Engine), Salt Water .....	149
Assistance, Rendering .....	27	Care and Maintenance .....	101
Attaching to the Tow Vehicle.....	158	Care, On-Going .....	102
Automatic Charging Relay (ACR).....	81	Carpet .....	110
Awlgrip Topcoat, Stationary Arch with .....	112	Category, Craft Design .....	6
Axles.....	162	Certifications .....	7
Ballast and Plumbing (Troubleshooting), Bilge .....	174	Certifications, Construction Standards.....	7
Basic Function Features .....	74	Chair Adjustments and Operation, Captain's.....	83
Basic Rules of the Road .....	32	Charger, Battery .....	81
Basic Safety Rules (Trailer).....	156	Check List Pre-Tow .....	169
Basic Safety Rules.....	12	Check List—Before Leaving the Dock, Pre-operation.....	13
Battery Charger .....	81	Chrome and Aluminum Components, Stainless Steel.....	102
Battery Connections.....	66	Circuit Breaker Panel .....	65
Battery Failure (Troubleshooting).....	173	Cleaning Advice, Additional .....	111
Battery Switch .....	81	Cleaning the Deck and Hull.....	110
Before Each Use.....	114	Cleaning, General .....	102
Before Leaving the Dock, Check List.....	13	Cleaning, Maintenance and Storage (Trailer).....	170
Before Operating.....	7	Cleats .....	75
Before You Start .....	96	Close the Coupler, To .....	159
Belt, Serpentine .....	141	Cobalt Certificate of Limited Warranty.....	122
Bilge (Cleaning) .....	112	Cobalt Trailers.....	156
Bilge Pump(s) .....	21	Cockpit Dinette Table.....	85
Bilge, Ballast and Plumbing (Troubleshooting) .....	174	Cockpit Tonneau Cover .....	91
Bimini Top with Easy Fold, Premium.....	91	Collisions.....	42
Bimini, Arch with.....	92	Comfort and Enhancements .....	82
Bimini, Electric Arch with .....	92	Communications, Radio .....	22
Black/White Electric or Folding Arch with Sunshade.....	93	Compartments (Care), Storage .....	109
Blower System (Troubleshooting).....	174	Compartments, Storage .....	84
Boarding .....	98	Compass .....	19
Boat Information (Form) .....	176	Components and Systems.....	59
Boat, Warranty Transfer .....	175	Compressor, Air .....	86
Boating Education, Owner Responsibility and .....	16	Condensation Cause and Prevention .....	105
Boating Regulations.....	32	Conditions, Hazardous .....	28
Boating Safety Education Opportunities .....	18	Connecting to the Boat.....	160
Boating Safety Topics, General .....	23	Connection to the Tow Vehicle .....	157
Boating Under the Influence.....	27	Connections, Battery.....	66
Bow Eye and Transom Eyes.....	75	Construction Standards/Certifications.....	7
Bow Filler Cushion, Removable.....	84	Construction, Features .....	7



Control, Cruise .....	78	Equipment, Recommended Spare.....	23
Controls, Wake Surf .....	78	Equipment, Safety and Required .....	19
Coolant Level, How to Check the Engine .....	152	E-Step—Flip Down.....	78
Coolant Requirements .....	146	Every 100 Hours.....	116
Coolant, Engine .....	140	Every 50 Hours.....	116
Cooler.....	86	Exhaust System.....	147
Cooling System (Engine).....	145	Explosion and Fire.....	41, 97
Cooling System, Engine/Propulsion .....	117	Explosion.....	41
Corrosion and Zinc Anodes, Galvanic .....	104	Exterior Care and Maintenance, Interior .....	102
Corrosion in Fresh Water .....	150	Extinguisher Manual Pull, Fire.....	65
Corrosion Protection .....	103	Extinguisher, Fire.....	21
CorrosionX .....	103	Eye and Transom Eyes, Bow.....	75
Coupler, To Close the .....	159	Fallen Skier or Rider .....	39
Coupler, To Open the .....	159	Features, Basic Function .....	74
Cover, Bow Tonneau .....	91	Features/Construction.....	7
Cover, Cockpit Tonneau .....	91	Filler Cushion, Removable Bow.....	84
Covers, Canvas and.....	90	Filter, Fuel .....	141
Cradle, Storage.....	118	Fire Extinguisher Manual Pull.....	65
Craft Design Category.....	6	Fire Extinguisher.....	21
Crossing.....	33	Fire Port .....	65
Cruise Control.....	78	Fire Suppression Equipment.....	64
Cup Holders.....	85	Fire .....	41
Cushion, Removable Bow Filler.....	84	Fire/Explosion .....	41, 97
Deck and Hull Finishes .....	110	Flip Down, E-Step .....	78
Deck and Hull, Cleaning the .....	110	Flip Down, Swim Step .....	77
Defects, Reporting Safety .....	156	Float Plan (Form).....	177
Develop WATER SENSE.....	39	Flooding, Swamping and .....	42
Devices, Person Flotation.....	20	Floor Covering Cleaning Instructions, Sea Grass .....	110
Disposal, Dockside Waste .....	89	Flotation Devices, Personal.....	20
Distress Signals, Visual.....	21	Focus on Prevention (Mold & Mildew).....	105
Dock and Mooring Lines, Handling.....	99	Fresh Water .....	87
Dockside Pump-Out .....	89	Fresh Water, Corrosion in .....	150
Dockside Waste Disposal .....	89	Freshwater System.....	69
Drowning.....	43	Fuel Filter .....	141
Easy Fold, Bimini Top with .....	91	Fuel Information .....	144
Education Opportunities, Boating Safety .....	18	Fuel Requirements.....	67
Education, Owner Responsibility and Boating .....	16	Fuel System (Maintenance).....	117
Electric Arch with Bimini .....	92	Fuel System .....	67
Electrical System (Engine).....	145	Fuel System, Monsoon .....	143
Electrical System (Maintenance) .....	117	Fuel Tank, EPA.....	69
Electrical System.....	65	Fueling .....	67
Electrical Systems (Troubleshooting).....	173	Fueling, When.....	144
Electrically Operated Head .....	88	Function Features, Basic.....	74
Embracing Safety .....	12	Fuses.....	66
Emergency Procedures.....	41	Galvanic Corrosion and Zinc Anodes.....	104
Emergency Safety Stop Switch.....	19	Gauges, Switches and Video Screens (Troubleshooting) .....	173
Emergency, Medical.....	43	General (Troubleshooting) .....	172
Emissions Information, California.....	143	General Boating Safety Topics .....	23
Encountering Another Vessel .....	32	General Cleaning.....	102
Engine Alarm .....	73	General Information (Engines) .....	139
Engine and/or Trailer, Warranty Transfer.....	175	General Prudential Rule .....	33
Engine Coolant.....	140	Getting Underway.....	95, 98
Engine Hatch.....	74	Glove Box .....	84
Engine Oil Maintenance.....	151	Grounding .....	42
Engine Oil.....	140	Guide Poles, Removable.....	161
Engine Option .....	137	Guidelines, Tow Line .....	39
Engine Specifications.....	140	Hand Signals .....	37
Engine/Propulsion/Cooling System .....	117	Handling Dock and Mooring Lines.....	99
Enhancements, Comfort and .....	82	Hatch, Engine .....	74
Entertainment System .....	86	Hazardous Conditions.....	28
Environmental Concerns .....	28	Head and Macerator, Marine Toilet .....	88
EPA Fuel Tank .....	69	Head, Electrically Operated .....	88
Equipment, Fire Suppression .....	64	Head-On, Meeting .....	33
Equipment, Other Navigation .....	19	Helm and Instrumentation .....	70
Equipment, Recommended Safety .....	22		



Helm Seat Electric Slide Operation.....83  
Hitch, Trailer .....157  
Hitching (Trailer) .....159  
Horn or Whistle.....21  
How to Check the Engine Coolant Level .....152  
How to Check the Engine Oil Level.....151  
How to Connect to the Tow Vehicle .....158  
Hubs, Wheels and .....162  
Hull Finishes, Deck and .....110  
Hull, Cleaning the Deck and .....110

If the Boat is Sold .....7  
Index, Troubleshooting, Logs and Index .....171  
Information, Fuel .....144  
Instrumentation, Helm and .....70  
Insurance .....18  
Interior/Exterior Care and Maintenance.....102  
Introduction .....1, 6

Jack, Trailer .....161

Labels, On-Product Warning .....30  
Ladder, Swim Platform and .....76  
Launching and Reloading the Boat from the Trailer .....170  
Leather Care .....108  
Legal Requirements for Towing .....156  
Lever, Tilt Steering Release .....73  
Licensing, Operation by Minors and .....18  
Life Raft .....23  
Lifting Slings, Using.....118  
Lifting the Boat.....118  
Light, Anchor .....87  
Lighting Operation, RGB .....87  
Lights (Trailer).....161  
Lights, Navigation.....19  
Limited Warranty, Cobalt Certificate of .....122  
Line Guidelines, Tow .....39  
Lines, Handling Dock and Mooring.....99  
Loading .....98  
Loading, Proper .....25  
Locations, Tie-Down.....74  
Log, Service .....178  
Logs and Index, Troubleshooting .....171  
Lubrication of the Steering System.....142  
Lug Nuts.....163

Macerator Pump .....89  
Macerator, Marine Toilet (Head) and .....88  
Macerator, Waste Disposal with Optional.....89  
Maintaining the Vessel, Safety While.....15  
Maintenance (Engine), Care and .....149  
Maintenance (Engine), Salt Water Care and .....149  
Maintenance and Service, Scheduled .....113  
Maintenance and Storage (Trailer), Cleaning.....170  
Maintenance Schedule, Monsoon Engine .....153  
Maintenance Schedule, Recommended Mercury Marine  
Outdrive .....153  
Maintenance, Care and .....101  
Maintenance, Engine Oil Maintenance.....151  
Maintenance, Unscheduled .....117  
Malibu Trailers Limited Warranty Statement.....130  
Marine Growth .....112  
Marine Toilet (Head) and Macerator .....88  
Mat Care and Maintenance, Swim Platform .....111  
Medical Emergency.....43  
Meeting Head-On .....33  
MerCruiser .....7

Mercury Marine Outdrive.....141  
Mildew Cause and Prevention, Mold &.....104  
Minors and Licensing, Operation by .....18  
Misuse, Product .....27  
Mold & Mildew Cause and Prevention.....104  
Monsoon Engine Maintenance Schedule.....153  
Monsoon Engine Support Systems.....143  
Monsoon Engines for Cobalt Boats.....138  
Monsoon Engines Limited Warranty Statement .....125  
Monsoon Fuel System.....143  
Monthly (Maintenance).....116  
Mooring Lines, Handling Dock and.....99  
Motor Box Assembly or Electric Motor Box Assembly.....80

Nautical Terms .....8  
Navigation Equipment, Other .....19  
Navigation Lights .....19  
Navigation, Aids to .....34  
Night Running.....35  
NMMA .....7  
Nuts, Lug.....163

Oil Lever, How to Check the Engine .....151  
Oil Maintenance, Engine .....151  
Oil, Engine.....140  
On and Under the Water .....76  
On the Water.....98  
On-Going Care .....102  
On-Product Warning Labels .....30  
Open to Coupler, To .....159  
Operating Information.....96  
Operating, Before .....7  
Operation by Minors and Licensing .....18  
Operation Failure.....43  
Operation, Prior to .....12  
Operator, Visibility for the .....26  
Opportunities, Boating Safety Education .....18  
Other Canvas Components.....109  
Other Navigation Equipment .....19  
Other Rules of the Road .....33  
Overboard, Person .....42  
Overtaking .....33  
Owner and Operators, Responsibilities of Boat .....17  
Owner Responsibility and Boating Education .....16  
Owner Responsibility/Warranty Procedure .....7

Panel, Circuit Breaker .....65  
Passenger Safety .....23  
Performance Boosts .....78  
Person Overboard .....42  
Personal Flotation Devices .....20  
Platform (Non-Teak), Swim .....112  
Platform and Ladder, Swim .....76  
Platform Dragging (“Teak Surfing”).....40  
Platform Mat Care and Maintenance, Swim .....111  
Platform, Teak Swim .....111  
Plumbing (Troubleshooting), Bilge, Ballast and .....174  
Poles, Removable Guide.....161  
Pooling Water .....106  
Port, Fire .....65  
Power Steering .....141  
Precautions for Towed Skier/Rider, Additional .....38  
Precautions While Underway.....13  
Precautions.....96  
Premium Bimini Top with Easy Fold.....91  
Pre-operation Check List—Before Leaving the Dock .....13  
Pre-Tow Check List .....169



Prior to Operation .....	12	Safety Responsibilities, Towed Person .....	37
Prior to Towing .....	169	Safety Rules (Trailer), Basic.....	156
Privileged Vessel .....	32	Safety Rules, Basic.....	12
Product Misuse .....	27	Safety Stop Switch, Emergency.....	19
Propeller.....	76	Safety Topics, General Boating .....	23
Proper Loading .....	25	Safety While Maintaining the Vessel.....	15
Proposition 65 .....	29	Safety, Carbon Monoxide .....	23
Propulsion System .....	98	Safety, Embracing .....	12
Propulsion/Cooling System, Engine.....	117	Safety, Passenger .....	23
Protection, Corrosion .....	103	Safety, Watersports.....	36
Prudential Rule, General .....	33	Salt Water Care and Maintenance (Engine).....	149
Publications .....	8	Salt Water Care and Maintenance.....	102
Pull, Fire Extinguisher Manual.....	65	Scheduled Maintenance and Service.....	113
Pump(s), Bilge .....	21	Screens (Troubleshooting), Gauges, Switches and Video .....	173
Pump, Macerator .....	89	Sea Grass Floor Covering Cleaning Instructions.....	110
Pump-Out, Dockside .....	89	Seating.....	82
Pylon, Ski Tow Eye .....	74	Serial Numbers .....	139
Quarterly (Maintenance).....	116	Serpentine Belt .....	141
R4 Outboard .....	48	Service Log.....	178
R4.....	46	Service, Scheduled Maintenance and .....	113
R6 Outboard .....	52	Shade, Bow.....	93
R6.....	50	Shower Water Pressure .....	88
R8 Outboard .....	56	Signal Words and Symbols Used in this Manual.....	12
R8.....	54	Signals, Hand .....	37
Radio Communications .....	22	Signals, Visual Distress .....	21
Raft, Life .....	23	Ski Tow Eye/Pylon .....	74
Reactivating the Boat After Storage .....	119	Skier or Rider, Fallen.....	39
Reboarding Methods .....	76	Slide Operation, Helm Seat Electric.....	83
Reboarding, Unassisted Means of .....	43	Slings, Using Lifting .....	118
Recommended Mercury Marine Outdrive Maintenance Schedule .....	153	Sold, If the Boat is Sold .....	7
Recommended Safety Equipment .....	22	Spare Equipment, Recommended.....	23
Recommended Spare Equipment .....	23	Specifications .....	45
Registration .....	18	Specifications, Engine.....	140
Regulations, Boating Regulations.....	32	Spot and Stain Removal .....	107
Relay (ACR), Automatic Charging .....	81	Stain Removal, Spot and .....	107
Release Lever, Tilt Steering .....	73	Stainless Steel, Chrome and Aluminum Components.....	102
Reloading the Boat from the Trailer, Launching and .....	170	Stainless Steel/Aluminum Arch with Sunshade .....	92
Removable Bow Filler Cushion.....	84	Start, Before You .....	96
Removable Guide Poles.....	161	Statements, Warranty.....	121
Rendering Assistance .....	27	Stationary Arch with Awlgrip Topcoat.....	112
Reporting Accidents.....	27	Staying Afloat.....	42
Reporting Safety Defects.....	156	Steering Release Lever, Tilt .....	73
Required Equipment, Safety and .....	19	Steering System Maintenance Schedule .....	113
Requirements, Warranty Services.....	7	Steering System, Lubrication of the .....	142
Responsibilities of Boat Owner and Operators .....	17	Steering, Power .....	141
Responsibilities, Safety and .....	11	Step—Flip Down, E.....	78
Responsibilities, Towed Person Safety .....	37	Step—Flip Down, Swim.....	77
Responsibility and Boating Education, Owner .....	16	Storage (Trailer), Cleaning, Maintenance and.....	170
RGB Lighting Operation .....	87	Storage and Winterization .....	118
Rider, Fallen Skier or .....	39	Storage Compartments (Care) .....	109
Routine Salt Water/Brackish.....	150	Storage Compartments .....	84
Routing.....	60	Storage Cradle.....	118
Rule, General Prudential .....	33	Storage, Reactivating the Boat After .....	119
Rules of the Road, Basic .....	32	Storage/Winterization General Information .....	119
Rules of the Road, Other .....	33	Sunshade, Stainless Steel/Aluminum Arch with .....	92
Rules, Basic Safety.....	12	Support Systems, Monsoon Engine .....	143
Safe Speed .....	23	Suppression Equipment, Fire.....	64
Safety (Engines) .....	138	Swamping and Flooding .....	42
Safety and Required Equipment .....	19	Swim Platform (Non-Teak) .....	112
Safety and Responsibilities .....	11	Swim Platform and Ladder.....	76
Safety Cables.....	157	Swim Platform Mat Care and Maintenance .....	111
Safety Defects, Reporting.....	156	Swim Platform, Teak .....	111
Safety Education Opportunities, Boating .....	18	Swim Step—Flip Down.....	77
Safety Equipment, Recommended .....	22	Switch, Battery .....	81
		Switch, Emergency Safety Stop .....	19
		Switch, Transom Tilt .....	81
		Switches and Video Screens (Troubleshooting), Gauges .....	173



Symbols Used in this Manual, Signal Words and.....	12	Vehicle, Connection to the Tow .....	157
Symbols .....	10	Vehicle, How to Connect to the Tow .....	158
System (Troubleshooting), Blower .....	174	Vessel, Burdened .....	32
System, Electrical.....	65	Vessel, Encountering Another .....	32
System, Entertainment.....	86	Vessel, Privileged .....	32
System, Freshwater.....	69	Vessel, Safety While Maintaining the .....	15
System, Fuel .....	67	Vinyl Interior and Upholstery .....	104
System, Propulsion .....	98	Vinyl: Dark Stowage Areas.....	108
Systems, Components and.....	59	Visibility for the Operator.....	26
Systems, Electrical (Troubleshooting).....	173	Visual Distress Signals.....	21
Table, Cockpit Dinette.....	85	Volvo Penta Ocean Series Outdrive.....	78
Teak Surfing, Platform Dragging.....	40	Volvo Penta.....	7
Teak Swim Platform .....	111	Wake Surf Controls .....	78
Terms, Nautical .....	8	Warning Labels, On-Product.....	30
Tie-Down Locations.....	74	Warranty Procedure, Owner Responsibility .....	7
Tie-Downs (Trailer).....	160	Warranty Services Requirements.....	7
Tilt Steering Release Lever.....	73	Warranty Statements.....	121
Tires .....	163	Warranty Transfer—Boat .....	175
Tonneau Cover, Bow.....	91	Warranty Transfer—Engine and/or Trailer.....	175
Tonneau Cover, Cockpit .....	91	Waste Disposal with Optional Macerator .....	89
Tool Kit .....	81	Waste Disposal, Dockside .....	89
Tow Line Guidelines .....	39	Water Pressure, Shower .....	88
Tow Vehicle, Connection to the .....	157	WATER SENSE, Develop.....	39
Tow Vehicle, How to Connect to the .....	158	Water System (Maintenance).....	117
Towed Person Safety Responsibilities .....	37	Water, Fresh.....	87
Towing Advice .....	169	Water, On and Under the .....	76
Towing.....	43	Water, On the.....	98
Towing, Legal Requirements for.....	156	Water, Pooling .....	106
Trailer Components and How They Function.....	161	Watersport Activities, Weighting Your Boat During .....	25
Trailer Hitch .....	157	Watersports Safety.....	36
Trailer Jack.....	161	Weight Distribution .....	158
Trailer Option .....	155	Weighting Your Boat During Watersport Activities.....	25
Trailer Winch.....	160	Welcome .....	2
Trailer, Warranty Transfer Engine and/or .....	175	Wheels and Hubs.....	162
Trailers, Cobalt.....	156	When Fueling.....	144
Transom Tilt Switch .....	81	When the Boat is Not in Operation (Fuel).....	145
Treatment (Mold & Mildew) .....	105	Whistle, Horn or .....	21
Troubleshooting (Fuel System) .....	69	Winch, Trailer.....	160
Troubleshooting.....	172	Windshield .....	112
Troubleshooting, Logs and Index .....	171	Windshield.....	85
Unassisted Means of Reboarding.....	43	Winterization General Information, Storage.....	119
Under the Influence, Boating .....	27	Winterization, Storage and .....	118
Under the Water, On and .....	76	Winterizing the Engine .....	152
Underway (Trailer) .....	169	Wood, Cabinetry and.....	109
Underway, Precautions While.....	13	Zinc Anodes, Galvanic Corrosion and .....	104
Unhitching (Trailer).....	159		
Unscheduled Maintenance .....	117		
Upholstery, Vinyl Interior and .....	104		
Using Lifting Slings.....	118		